

8-Bit MCU with 1Kx16 (ECC) SRAM and 16Kx16 (ECC) E-Flash

GENERAL DESCRIPTION

CS8975 is a general-purpose MCU with 16KB Code e-Flash memory with ECC and 1K SRAM with ECC. The embedded flash for code storage has built-in ECC that corrects 1-bit error and detects two-bit errors. CPU accesses the e-Flash through address read and through Flash Controller which can perform software read/write operations of e-Flash.

CPU in CS8975 is a 1-T 8051 with enhanced multiplication and division accelerator. There are three clock sources for the system, one is a 16MHz/32MHz IOSC (manufacturer calibration +/- 2%), another is XCLK, and the other one is SOSC32KHz (typical 32KHz) which is divided from an internal slow oscillator. ALL clock sources have a clock programmable divider for scaling down the frequency to save power dissipations. The clock selections are combined with flexible power management schemes, including NORMAL, IDLE, STOP, and SLEEP modes to balance speed and power consumption.

There are T0/T1/T2/T3/T4/T5 timers coupled with CPU and three WDT where WDT1 is clocked by SYSCLK, and WDT2/WDT3 are clocked by a non-stop SOSC32KHz. An 8-bit/16-bit checksum and 16-bit CRC accelerator is included. There are EUART/LIN controller, I²C master/Slave controller and SPI master/slave controller. The interfaces of these controllers are multiplexed with GPIO pins. Other useful peripherals include a buzzer control, 6 channels of 12-bit PWM, one channel of 16-bit timer/capture and quadrature decoder.

Analog peripherals include an 11-bit ADC with an internal temperature sensor, an 8-bit voltage output DAC, and four analog comparators with a programmable threshold. A touch key controller with up to 20-bit resolutions is also included. The touch key controller also has shield output capability for moisture immunity. The touch key controller allows sleep mode (under 10uA) and uses auto-detection for wakeup. The maximum number of sensor keys is 11. CS8975 can support passive proximity sensing.

CS8975 also provides a flexible method of flash programming that supports ISP and IAP. The protection of data loss is implemented in hardware by access restriction of critical storage segments. The code security is reinforced with sophisticated writer commands and ISP commands. The on-chip breakpoint processor also allows easy debugging which can be integrated with ISP. Reliable power-on-reset circuit and low supply voltage detection allow reliable operations under harsh environments.

APPLICATION

- Touch key applications with high robustness and reliability requirements
- Automotive, Industry and Appliance

FEATURE

CPU and Memory

- 1-Cycle 8051 CPU core up to 32MHz
- 16-bit Timers T0/T1/T2/T3/T4 and 24-bit T5
- Checksum and CRC accelerator
- WDT1 by SYSCLK, WDT2/WDT3 by SOSC32KHz
- Clock fault monitor
- All GPIO pins can be assigned to two external interrupts
- Power-saving modes – IDLE, STOP, and SLEEP
- 256B IRAM and 768B XRAM with ECC check
- 16KB Code e-Flash with ECC and two 512x16 Information Block
 - Program read with hardware ECC
 - 16-bit software read/write direct access
 - Code security and data loss protection
 - 100K endurance and 10 years retention

Clock Source

- Internal oscillator at 16MHz/32MHz +/- 2%
 - Spread Spectrum option
- Internal low power oscillator 128KHz
- External clock option

Digital Peripheral

- 6 CH 8/10/12-bit center-aligned PWM controller

- Trigger interrupt and ADC conversion
- Output polarity control
- One 16-bit Timer/Capture and One 16-bit quadrature decoder
- Buzzer/Melody generator
- One I²C Master
- One I²C Slave – also for ISP and debug
- One SPI Master/Slave Controller
- One EUART1 and one EUART2/LIN

Analog Peripheral

- Capacitance sense touch-key controller with scan up to 11 key inputs
 - Shield output for moisture immunity
 - Low power sleep mode wakeup (<5uA).
- 11-Bit SAR ADC with GPIO analog input
 - Temperature sensor and voltage supply measurement
- 8-Bit DAC and four analog comparators
- Power-on reset and Low voltage detect (2.3V-4.5V)

Miscellaneous

- Up to 12 GPIO pins with multi-function options
- 2.3V to 5.5V single supply
- Active current < 150uA/MHz in Normal mode

IS32CS8975

- Low power standby (< 1uA) in SLEEP mode
- Operating temperature -40°C to 125°C
- SOP-8, TSSOP-16 and wettable flank QFN-16 (WQFN-16) package
- RoHS & Halogen-Free compliant
- TSCA compliance
- AEC-Q100 qualification

BLOCK DIAGRAM

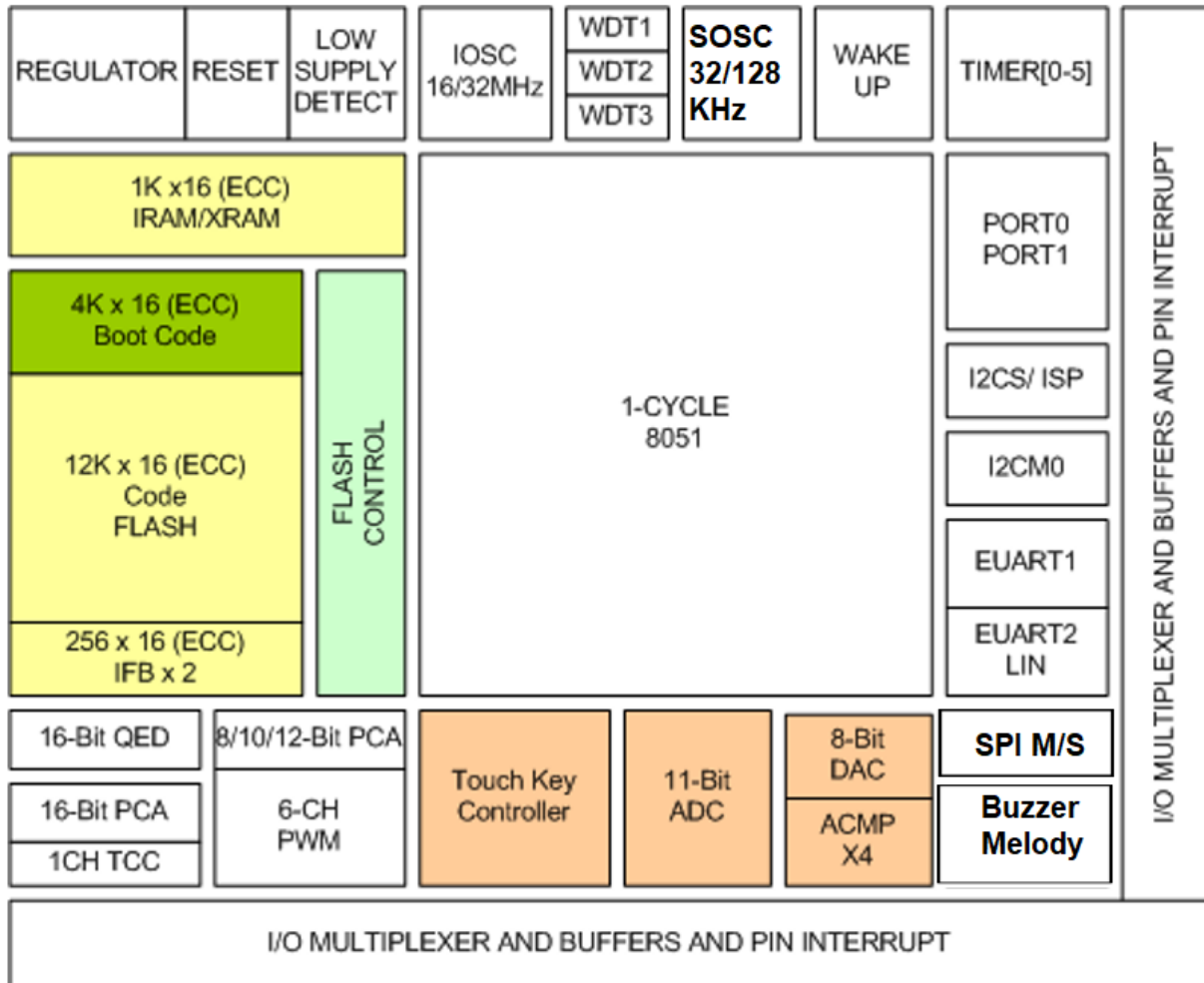

Table of Contents

1. PIN Description and Multifunction Table	1
2. Memory Map.....	3
3. REGISTER MAP SFR (0x80 – 0xFF).....	4
4. TA protected REGISTER MAP XFR (0xA000 – 0xAFFF)	5
5. 8051 CPU	7
5.1 CPU Register	7
5.2 Addressing Timing and Memory Modes	8
5.3 MOVX A, @Ri Instructions.....	9
5.4 Dual Data Pointers and MOVX operations.....	9
5.5 Interrupt System.....	11
5.6 Register Access Control.....	14
5.7 Clock Control and Power Management Modes	15
5.7.1 IDLE Mode.....	17
5.7.2 STOP Mode	17
5.7.3 SLEEP Mode.....	17
5.7.4 Clock Control.....	17
5.8 Watchdog Timer.....	17
5.9 System Timers – T0 and T1	20
5.9.1 Mode 0.....	21
5.9.2 Mode 1	22
5.9.3 Mode 2	22
5.9.4 Mode 3	22
5.10 System Timer – T2.....	23
5.11 System Timer – T3 and T4.....	25
5.12 System Timer – T5.....	26
5.13 Multiplication and Division Unit (MDU)	27
5.13.1 Division – 32-bit divide by 16-bit or 16-bit divide by 16-bit.....	29
5.13.2 Multiplication – 16-bit multiply by 16-bit	29
5.13.3 Normalization – 32-bit.....	30
5.13.4 Shift – 32-bit.....	30
5.13.5 MDU Flag.....	30
5.14 I ² C Master	30
5.15 Checksum/CRC Accelerator	33
5.16 Break Point and Debug Controller	34
5.17 Debug I ² C Port.....	37
5.18 Data SRAM ECC Handling	37
5.19 Program ECC Handling.....	38
5.20 Memory and Logic BIST Test.....	39
5.21 System Clock Monitoring	40
5.22 Reset.....	40
6. Flash Controller	42
7. I²C Slave Controller 2 (I2CS2).....	46
8. EUART1 Enhanced Function UART1	49
9. EUART2 with LIN Controller	53
10. Serial Peripheral Interface (SPI).....	62
10.1 SPI Master Timing Illustration	63
10.1.1 CPOL=0 CPHA=0	63
10.1.2 CPOL=0 CPHA=1	64
10.1.3 CPOL=1 CPHA=0	64
10.1.4 CPOL=1 CPHA=1	64
10.2 SPI Slave Timing Illustration	65
10.2.1 CPOL=0 CPHA=0	65
10.2.2 CPOL=0 CPHA=1	65
10.2.3 CPOL=1 CPHA=0	66
10.2.4 CPOL=1 CPHA=1	66
11. Timer with Compare/Capture and Quadrature Encoder	67
12. PWM Controller.....	73
13. Buzzer and Melody Controller	76

IS32CS8975

14. Core Regulator and Low Voltage Detection	79
14.1 Supply Low Voltage Detection (LVD)	79
15. IOSC and SOSC	81
15.1 IOSC 16MHz/32MHz.....	81
15.2 SOSC 128KHz	82
16. 11-Bit SAR ADC (ADC)	83
17. Analog Comparators (ACMP) and 8-bit DAC	86
18. Touch Key Control III	89
19. GPIO Multi-Function Select and Pin Interrupt	94
20. Information Block IFB	96
21. Writer Mode	98
22. Boot Code and In-System Programming	100
23. Electrical Specifications	101
23.1 Absolute Maximum Ratings	101
23.2 Recommended Operating Condition	101
23.3 DC Electrical Characteristics (VDD = 2.35V to 5.5V TA=-40°C to 125°C)	101
23.4 AC Electrical Characteristics (VDD =2.3V to 5.5V TA=-40°C to 125°C)	102
23.5 Classification Reflow Profiles	103
24. Packaging Outline	105
24.1 8-pin SOP	105
24.1.1 Recommended Land Pattern.....	105
24.1.2 POD	106
24.2 16-pin TSSOP	107
24.2.1 Recommended Land Pattern.....	107
24.2.2 POD	108
24.3 16-pin WQFN	109
24.3.1 Recommended Land Pattern.....	109
24.3.2 POD	110
25. Ordering Information.....	111
26. Errata	112
27. Revisions.....	113

List of Tables

1. PIN Description and Multifunction Table	1
Table 1-1 PIN Description Table	1
Table 1-2 PIN Multifunction Table	2
3. REGISTER MAP SFR (0x80 – 0xFF)	4
Table 3-1 SFR Register map	4
4. TA protected REGISTER MAP XFR (0xA000 – 0xAFFF)	5
Table 4-1 TA protected REGISTER MAP	6
5. 8051 CPU	7
Table 5-1 Interrupt sources and interrupt vectors	11
20. Information Block IFB	96
Table 20-1 Information Block (IFB)	97
21. Writer Mode	98
Table 21-1 Timing diagram for Writer Mode access	98

List of Figures

2. Memory Map	3
Figure 2-1 Memory Map	3
5. 8051 CPU	7
Figure 5-1 Watchdog Timer block diagram	18
Figure 5-2 Timer/Counter Mode 0: 13-bit counter	22
Figure 5-3 Timer/Counter Mode 1: 16-bit counter	22
Figure 5-4 Timer/Counter Mode 2: 8-bit re-load	22
Figure 5-5 Timer/Counter Mode 3: Two 8-bit counters.....	23
Figure 5-6 Timer 2 block diagram of Auto-reload and Capture.....	24
Figure 5-7 Timer 2 block diagram of Baud Rate Generator.....	25
Figure 5-8 Timer 3 and Timer 4 block diagram.....	25
Figure 5-9 Timer 5 block diagram.....	27
Figure 5-10 System Clock Monitor diagram	40
Figure 5-11 Reset block diagram	41
9. EUART2 with LIN Controller	53
Figure 9-1 EUART2 with LIN Controller block diagram	53
Figure 9-2 LIN frame structure	56
Figure 9-3 LIN frame timing.....	56
Figure 9-4 Finite State Machine of the LIN extension.....	57
10. Serial Peripheral Interface (SPI)	62
Figure 10-1 SPI Master Timing with CPOL=0, CPHA=0	63
Figure 10-2 SPI Master Timing with CPOL=0, CPHA=1	64
Figure 10-3 SPI Master Timing with CPOL=1, CPHA=0	64
Figure 10-4 SPI Master Timing with CPOL=1, CPHA=1	64
Figure 10-5 SPI Slave Timing with CPOL=0, CPHA=0	65
Figure 10-6 SPI Slave Timing with CPOL=0, CPHA=1	65
Figure 10-7 SPI Slave Timing with CPOL=1, CPHA=0	66
Figure 10-8 SPI Slave Timing with CPOK=1, CPHA=1	66
11. Timer with Compare/Capture and Quadrature Encoder	67
Figure 11-1 TCC implementations diagram.....	67
Figure 11-2 TCC timing diagram	68
Figure 11-3 QE implementation diagram.....	70
Figure 11-4 Timing diagram of CHA/CHB with X1/X2/X4 modes	71
13. Buzzer and Melody Controller	76
Figure 13-1 Buzzer and Melody output timing diagram	76
14. Core Regulator and Low Voltage Detection	79
Figure 14-1 LVD Threshold VX LVDTHD[6-0].....	79
15. IOSC and SOSC	81
Figure 15-1 IOSC sweep rate and amplitude of Spread Spectrum.....	81
16. 11-Bit SAR ADC (ADC)	83
Figure 16-1 11-bit SAR ADC block diagram.....	83
17. Analog Comparators (ACMP) and 8-bit DAC	86
Figure 17-1 ACMP and 8-bit DAC block diagram	86
18. Touch Key Control III	89
Figure 18-1 TK3 signals timing diagram	89
Figure 18-2 Timing diagram of Auto Detection in Sleep mode	90
21. Writer Mode	98
Figure 21-1 Timing diagram for Writer Mode access.....	98

List of Registers

5. 8051 CPU 7

ACC (0xE0) Accumulator R/W (0x00) 7

B (0xF0) B Register R/W (0x00) 7

PSW (0xD0) Program Status Word R/W (0x00) 7

SP (0x81) Stack Pointer R/W (0x00) 7

ESP (0x9B) Extended Stack Pointer R/W (0x00) 7

STATUS (0xC5) Program Status Word RO(0x00) 7

WTST (0x92) R/W (0x07) 8

MCON (0xC6) XRAM Relocation Register R/W (0x00) TA Protected 8

ACON (0x9D) R/W (0x00) TA Protected 9

DPXR (0xDA) R/W (0x00) 9

MXAX (0xEA) MOVX Extended Address Register R/W (0x00) 9

DPS (0x86) Data Pointer Select R/W (0x00) 9

DPL (0x82) Data Pointer Low R/W (0x00) 10

DPH (0x83) Data Pointer High R/W (0x00) 10

DPL1 (0x84) Extended Data Pointer Low R/W (0x00) 10

DPH1 (0x85) Extended Data Pointer High R/W (0x00) 10

DPX (0x93) Data Pointer Top R/W (0x00) 10

DPX1 (0x95) Extended Data Pointer Top R/W (0x00) 10

IE (0xA8) Interrupt Enable Register R/W (0x00) 12

EXIE (0xE8) Extended Interrupt Enable Register R/W (0x00) 12

IP (0xB8) Interrupt Priority Register R/W (0x00) 12

EXIP (0xF8) Extended Interrupt Priority Register R/W (0x00) 12

EXIF (0x91) Extended Interrupt Flag R/W (0x00) 12

WKMASK (0x9F) R/W (0xFF) Wake Up Mask Register TB Protected 13

TCON (0x88) R/W (0x00) 13

TA (0xC7) Time Access A Control Register2 WO xxxxxxx0 14

TB (0xC9) Time Access B Control Register2 RW (0x00) 14

PCON (0x87) R/W (0x00) 15

PMR (0xC4) R/W (010xxxxx) 15

CKSEL (0x8F) System Clock Selection Register R/W (0x0C) TB Protected 15

WKMASK (0x9F) R/W (0xFF) Wake-Up Mask Register TB Protected 16

WDCON (0xD8) WDT1 Interrupt Flag Register R/W (0x02) TA Protected for WDT1CLR bit only 18

CKCON (0x8E) Clock Control and WDT1 R/W (0xC7) 18

WDT2CF (0xA0D8h) Watchdog Timer 2 Configure Registers R/W (0xA7) TB Protected 19

WDT2L (0xA0D9h) Watchdog Timer 2 Time Out Value Low Byte RW (0xFF) TB Protected 19

WDT2H (0xA0DAh) Watchdog Timer 2 Time Out Value High Byte RW (0x0F) TB Protected 20

WDT3CF (0xA0DBh) Watchdog Timer 3 Configure Registers R/W (0xD1) TB Protected 20

WDT3L (0xA0DCh) Watchdog Timer 3 Time Out Value Low Byte RO R/W (0xFF) TB Protected 20

WDT3H (0xA0DDh) Watchdog Timer 3 Time Out Value High Byte RO R/W (0x0F) TB Protected 20

TCON (0x88) R/W (0x00) 21

TMOD (0x89h) Timer 0 and 1 Mode Control Register R/W (0x00) 21

TL0 (0x8Ah) Timer 0 Low Byte Register R/W (0x00) 23

TH0 (0x8Ch) Timer 0 High Byte Register 0 R/W (x00) 23

TL1 (0x8Bh) Timer 1 Low Byte Register 0 R/W (0x00) 23

TH1 (0x8Dh) Timer 1 High Byte Register 0 R/W (0x00) 23

T2CON (0xC8h) Timer 2 Control and Configuration Register R/W (0x00) 23

TL2 (0xCCh) Timer 2 Low Byte Register 0 R/W (0x00) 25

TH2 (0xCDh) Timer 2 High Byte Register 0 R/W (0x00) 25

RLDL (0xCAh) Timer 2 reload Low Byte Register 0 R/W (0x00) 25

RLDH (0xCBh) Timer 2 reload High Byte Register 0 R/W (0x00) 25

T34CON (0xCFh) Timer 3 and Timer 4 Control and Status Register R/W (00000000) 26

TL3 (0xAEh) Timer 3 Low Byte Register 0 R/W 00000000 26

TH3 (0xAFh) Timer 3 High Byte Register 0 R/W 00000000 26

TL4 (0xACh) Timer 4 Low Byte Register 0 R/W 00000000 26

TH4 (0xADh) Timer 4 High Byte Register 0 R/W 00000000 26

T5CON (0xA068h) Timer 5 Control and Status Register R/W (00000000) 27

TL5 (0xA069) Timer5 Low Byte Register 0 R/W (0x00) 27

TH5 (0xA06A) Timer5 Medium Byte Register 0 R/W (0x00) 27

TT5 (0xA06B) Timer5 High Byte Register 0 R/W (0x00) 27

ARCON (0xFF) MDU Control R/W (0x00) 28

MD0 (0xF9) MDU Data Register 0 R/W (0x00) 28

MD1 (0xFA) MDU Data Register 1 R/W (0x00) 28

MD2 (0xFB) MDU Data Register 2 R/W (0x00) 28

MD3 (0xFC) MDU Data Register 3 R/W (0x00) 28

MD4 (0xFD) MDU Data Register 4 R/W (0x00) 28

MD5 (0xFE) MDU Data Register 5 R/W (0x00) 29

I2CMTP (0xF7h) I ² C Master Time Period R/W (x00).....	31
I2CMSA (0xF4) I ² C Master Slave Address R/W (0x00).....	31
I2CMBUF (0xF6) I ² C Master Data Buffer Register R/W (0x00).....	31
I2CMCR (0xF5) I ² C Master Control and Status Register R/W (0x00).....	31
I2CMTO (0xC3) I ² C Time Out Control Register R/W (0x00).....	33
CCCFG (0xA078h) Checksum/CRC Accelerator Configuration Register R/W (0x00).....	33
CCDATA0 (0xA07Ch) Checksum/CRC Data Register 0 R/W (0x00).....	34
CCDATA1 (0xA07Dh) Checksum/CRC Data Register 1 R/W (0x00).....	34
CCDATA2 (0xA07Eh) Checksum/CRC Data Register 2 R/W (0x00).....	34
CCDATA3 (0xA07Fh) Checksum/CRC Data Register 2 R/W (0x00).....	34
BPINTF (A0E0h) Break Point Interrupt Flag Register R/W (0x00).....	35
BPINTE (A0E1h) Break Point Interrupt Enable Register R/W (0x00) TB Protected.....	35
BPINTC (A0E2h) Break Point Interrupt Control Register R/W (0x00).....	35
BPCTRL (A0E3h) DBG and BKP ISR Control and Status Register R/W (0xFC).....	35
PC1AL (A0F0h) Program Counter Break Point 1 Low Address Register R/W (0x00).....	36
PC1AH (A0F1h) Program Counter Break Point 1 High Address Register R/W (0x00).....	36
PC1AT (A0F2h) Program Counter Break Point 1 Top Address Register R/W (0x00).....	36
PC2AL (A0F4h) Program Counter Break Point 2 Low Address Register R/W (0x00).....	36
PC2AH (A0F5h) Program Counter Break Point 2 High Address Register R/W (0x00).....	36
PC2AT (A0F6h) Program Counter Break Point 2 Top Address Register R/W (0x00).....	36
DBPCIDL (A098h) Debug Program Counter Address Low Register RO (0x00).....	36
DBPCIDH (A099h) Debug Program Counter Address High Register RO (0x00).....	37
DBPCIDT (A09Ah) Debug Program Counter Address Top Register RO (0x00).....	37
DBPCNXL (A09Bh) Debug Program Counter Next Address Low Register RO (0x00).....	37
DBPCNXH (A09Ch) Debug Program Counter Next Address High Register RO (0x00).....	37
DBPCNXT (A09Dh) Debug Program Counter Next Address Top Register RO (0x00).....	37
STEPCTRL (A09Eh) Single Step Control Enable Register R/W (0x00).....	37
SI2CDBGID (A09Fh) Slave I ² C Debug ID Register R/W (0x36) TB Protected.....	37
DECCCFG (0xA02Dh) Data ECC Configuration Register R/W (0x80) TB Protected.....	38
DECCADL (0xA02Eh) Data ECC Configuration and Address Register Low RO (0x00).....	38
DECCADH (0xA02Fh) Data ECC Configuration and Address Register High R/W (0x80).....	38
PECCCFG (0xA00Dh) Program ECC Configuration Register R/W (0x80) TB Protected.....	38
PECCADL (0xA00Eh) Program ECC Fault Address Register Low RO (0x00).....	39
PECCADH (0xA00Fh) Program ECC Fault Address Register High R/W (0x80).....	39
BSTCMD (0xA016h) SRAM Built-In and Logic Self Test R/W (0x00) TB Protected.....	39
TSTMON (0xA014h) Test Monitor Flag R/W (0x00).....	40
RSTCMD (0xA017h) Reset Command Register R/W (0x00) TB Protected.....	41
6. Flash Controller.....	42
FLSHCMD (0xA025h) Flash Controller Command Register R/W (0x80) TB Protected.....	42
FLSHDATL (0xA020h) Flash Controller Data Register R/W (0x00).....	43
FLSHDATH (0xA021h) Flash Controller Data Register R/W (0x00).....	43
FLSHADL (0xA022h) Flash Controller Low Address Data Register R/W (0x00).....	43
FLSHADH (0xA023h) Flash Controller High Address Data Register R/W (0x00).....	43
FLSHECC (0xA024h) Flash ECC Accelerator Register R/W (0000 0000).....	43
ISPCLKF (0xA026h) Flash Command Clock Scaler R/W (0x25) TB Protected.....	43
FLSHPRT0 (0xA030h) Flash Controller Zone Protection Register 0 R/W (0xFF) TB Protected.....	44
FLSHPRT1 (0xA031h) Flash Controller Zone Protection Register 1 R/W (0xFF) TB Protected.....	44
FLSHPRT2 (0xA032h) Flash Controller Zone Protection Register 2 R/W (0xFF) TB Protected.....	44
FLSHPRT3 (0xA033h) Flash Controller Zone Protection Register 3 R/W (0xFF) TB Protected.....	44
FLSHPRT4 (0xA034h) Flash Controller Zone Protection Register 4 R/W (0xFF) TB Protected.....	44
FLSHPRT5 (0xA035h) Flash Controller Zone Protection Register 5 R/W (0xFF) TB Protected.....	44
FLSHPRT6 (0xA036h) Flash Controller Zone Protection Register 6 R/W (0xFF) TB Protected.....	44
FLSHPRT7 (0xA037h) Flash Controller Zone Protection Register 7 R/W (0xFF) TB Protected.....	44
FLSHPRTC (0xA027h) Flash Controller Code Protection Register R/W (0x00) TB Protected.....	45
FLSHVDD (0xA015h) Flash VDD Switch Control Register R/W (0x00) TB Protected.....	45
7. I²C Slave Controller 2 (I2CS2).....	46
I2CSCON2 (0xDB) I2CS2 Configuration Register R/W (0x00).....	46
I2CSST2 (0xDC) I2CS2 Status Register R/W (0x00).....	47
I2CSADR2 (0xDD) I2CS2 Slave Address Register R/W (0x00).....	47
I2CSDAT2 (0xDE) I2CS2 Data Register R/W (0x00).....	48
8. EUART1 Enhanced Function UART1.....	49
SCON1 (0xB1) EUART1 Configuration Register, R/W (0x00).....	49
SCON1X (0xB2) EUART1 Configuration Register, R/W (0x00).....	49
SFIFO1 (0xB3) EUART1 FIFO Status/Control Register R/W (0x00).....	50
SINT1 (0xB5) EUART1 Interrupt Status/Enable Register R/W (0x00).....	51
SBUF1 (0xB4) EUART1 Data Buffer Register R/W (0x00).....	51
SBR1L (0xB6) EUART1 Baud Rate Register Low byte RO (0x00).....	51

SBR1H (0xB7) EUART1 Baud Rate Register High byte RO (0x00)	52
9. EUART2 with LIN Controller	53
SCON2 (0xC2) UART2 Configuration Register R/W (0x00)	53
SFIFO2 (0xA5) UART2 FIFO Status/Control Register R/W (0x00)	54
SINT2 (0xA7) UART2 Interrupt Status/Enable Register R/W (0x00)	55
SBUF2 (0xA6) UART2 Data Buffer Register R/W (0x00)	56
LINCTRL (0xA090) LIN Status/Control Register R/W (0x00)	57
LINCNTRH (0xA091) LIN Timer Register High R/W (0xFF)	58
LINCNTRL (0xA092) LIN Time Register Low R/W (0xFF)	58
LINSBRH (0xA093) EUART/LIN Baud Rate Register High byte RO (0x00)	58
LINSBRL (0xA094) EUART/LIN Baud Rate Register Low byte (0x00) RO	59
LININT (0xA095) LIN Interrupt Flag Register R/W (0x00)	59
LININTEN (0xA096) LIN Interrupt Enable Register R/W (0x00)	60
LINTCON (0xA0B0h) LIN Time Out configuration R/W (0x00)	60
TXDTOL (0xA0B1h) LIN TXD Dominant Time Out LOW Registers R/W (0x00)	60
TXDTH (0xA0B2h) LIN TXD Dominant Time Out HIGH Registers R/W (0x00)	60
RXDTOL (0xA0B3h) LIN RXD Dominant Time Out LOW Registers R/W (0x00)	61
RXDTH (0xA0B4h) LIN RXD Dominant Time Out HIGH Registers R/W (0x00)	61
BSDCLRL (0xA0B5h) Bus Stuck Dominant Clear Width Low Registers R/W (0x00)	61
BSDCLRH (0xA0B6h) Bus Stuck Dominant Clear Width High Registers R/W (0x00)	61
BSDACT (0xA0B8h) Bus Stuck Dominant Active Width Registers R/W (0x00)	61
BSDWKC (0xA0B7h) Bus Stuck Dominant Fault Wakeup configuration R/W (0x00)	61
10. Serial Peripheral Interface (SPI)	62
SPICR (0xA1) SPI Configuration Register R/W (0b001000xx)	62
SPIMR (0xA2) SPI Mode Control Register R/W (0x00)	62
SPIST (0xA3) SPI Status Register R/W (0x00)	63
SPIDATA (0xA4) SPI Data Register R/W (0xXX)	63
11. Timer with Compare/Capture and Quadrature Encoder	67
TCCFG1 (0xA050h) TCC Configuration Register 1 R/W (0x00)	67
TCCFG2 (0xA051h) TC Configuration Register 2 R/W (0x00)	68
TCCFG3 (0xA052h) TC Configuration Register 3 R/W (0x00)	68
TCPRDL (0xA054h) TC Period Register Low Double Buffer R/W (0x00)	69
TCPRDH (0xA055h) TC Period Register High Double Buffer R/W (0x00)	69
TCCMPL (0xA056h) TC Compare Register Low Double Buffer R/W (0x00)	69
TCCMPH (0xA057h) TC Compare Register High Double Buffer R/W (0x00)	69
TCCPTRL (0xA060h) TC Capture Register R Low R/W (0x00)	69
TCCPTRH (0xA061h) TC Capture Register R High R/W (0x00)	69
TCCPTFL (0xA062h) TC Capture Register F Low R/W (0x00)	70
TCCPTFH (0xA063h) TC Capture Register F High R/W (0x00)	70
QECFG1 (0xA070h) TCC Configuration Register 1 R/W (0x00)	70
QECFG2 (0xA071h) QE Configuration Register 2 R/W (0x00)	71
QECFG3 (0xA072h) QE Configuration Register 3 R/W (0x00)	71
QECNTL (0xA074h) QE Counter LOW R/W (0x00)	72
QECNTH (0xA075h) QE Counter High R/W (0x00)	72
QEMAXL (0xA076h) QE Counter Low R/W (0x00)	72
QEMAXH (0xA077h) QE Counter High R/W (0x00)	72
12. PWM Controller	73
PWMCFG1 (0xA080h) PWM Clock Scaling Setting Register R/W (0x00)	73
PWMCFG2 (0xA081h) PWM Interrupt Enable and Flag Register R/W (0x00)	73
PWMCFG3 (0xA082h) PWM Configuration 3 Register R/W (0x00)	73
PWM0DTYL (0xA084h) PWM0 Duty Register L R/W (0x00)	74
PWM0DTYH (0xA085h) PWM0 Duty Register H R/W (0x00)	74
PWM1DTYL (0xA086h) PWM1 Duty Register L R/W (0x00)	74
PWM1DTYH (0xA087h) PWM1 Duty Register H R/W (0x00)	74
PWM2DTYL (0xA088h) PWM2 Duty Register L R/W (0x00)	74
PWM2DTYH (0xA089h) PWM2 Duty Register H R/W (0x00)	74
PWM3DTYL (0xA08Ah) PWM3 Duty Register L R/W (0x00)	74
PWM3DTYH (0xA08Bh) PWM3 Duty Register H R/W (0x00)	74
PWM4DTYL (0xA08Ch) PWM3 Duty Register L R/W (0x00)	74
PWM4DTYH (0xA08Dh) PWM3 Duty Register H R/W (0x00)	75
PWM5DTYL (0xA08Eh) PWM5 Duty Register LR/W (0x00)	75
PWM5DTYH (0xA08Fh) PWM5 Duty Register H R/W (0x00)	75
13. Buzzer and Melody Controller	76
NTAFRQL (0xA040h) Note A Frequency Register R/W (0x00)	76
NTAFRQH (0xA041h) Note A Frequency Register R/W (0x00)	76

NTADUR (0xA042h) Note A Duration Register R/W (0x00)	76
NTAPAU (0xA043h) Note A Pause Register R/W (0x00)	76
NTBFRQL (0xA044h) Note B Frequency Register R/W (0x00)	76
NTBFRQH (0xA045h) Note B Frequency Register R/W (0x00)	77
NTBDUR (0xA046h) Note B Duration Register R/W (0x00)	77
NTBPAU (0xA047h) Note B Pause Register R/W (0x00)	77
NTPOW (0xA049h) Note Power On Window Register R/W (0x00)	77
NTTU (0xA04Ah) Note Time Unit Register R/W (0x00)	77
BZCFG (0xA048h) Buzzer Configure Register R/W (0x00)	77
14. Core Regulator and Low Voltage Detection	79
REGTRM (0xA000h) Regulator Trim Register R/W (0x80) TB protected	79
LVDCFG (0xA010h) Supply Low Voltage Detection Configuration Register R/W (0x08) TB Protected except bit 0 LVTIF ..	79
LVDTHD (0xA011h) Supply Low Voltage Detection Threshold Register R/W (0bx1111111) TB Protected	80
LVDHYS (0xA012h) Supply Low Voltage Detection Threshold Hysteresis Register R/W (0x00) TB Protected	80
15. IOSC and SOSC	81
IOSCITRM (0xA001h) IOSC Coarse Trim Register R/W (0x01) TB Protected	81
IOSCVTRM (0xA002h) IOSC Fine Trim Register R/W (0x80) TB Protected	81
SOSCTRM (0xA007h) SOSC Trim Register R/W (0x10) TB Protected	82
16. 11-Bit SAR ADC (ADC)	83
ADCCFG (0xA9h) ADC Configuration Register R/W (0x00)	83
ADCCTL (0xCEh) ADC Control Register R/W (0x00)	84
ADCL (0xBAh) ADC Result Register Low Byte RO (0xFF)	84
ADCH (0xBBh) ADC Result Register High Byte RO (0xFF)	85
17. Analog Comparators (ACMP) and 8-bit DAC	86
CMPCFGAB (0xA038h) Analog Comparator A/B Configuration Register R/W (0x00)	86
CMPCFGCD (0xA039h) Analog Comparator C/D Configuration Register R/W (0x00)	87
CMPVTH0 (0xA03Ah) Analog Comparator Threshold Control Register R/W (0x00)	87
CMPVTH1 (0xA03Bh) Analog Comparator Threshold Control Register R/W (0x00)	87
CMPOST (0xA03Dh) Analog Comparator Status Register R/W (0x00)	87
DACCFG (0xA03Ch) Analog Comparator Status Register R/W (0x00)	88
18. Touch Key Control III	89
TK3CFGA (0xA018h) TK3 Configuration Register A R/W (0x00)	90
TK3CFGB (0xA019h) TK3 Configuration Register B R/W (0x00)	90
TK3CFGC (0xA01Ah) TK3 Configuration Registers C R/W (0x00)	91
TK3CFGD (0xA01Bh) TK3 Configuration Registers D R/W (0x00)	92
TK3HDTYL (0xA01Ch) TK3 High Duty Count Register L RO (0x00)	92
TK3HDTYH(0xA01Dh) TK3 High Duty Count Register H RO (0x00)	92
TK3LDTYL (0xA01Eh) TK3 Low Duty Count Register L RO (0x00)	92
TK3LDTYH(0xA01Fh) TK3 Low Duty Count Register H RO (0x00)	92
TK3BASEL (0xA028h) TK3 Baseline Register L R/W (0x00)	93
TK3BASEH (0xA029h) TK3 Baseline Register H R/W (0x00)	93
TK3THDL (0xA02Ah) TK3 Threshold Register L R/W (0x00)	93
TK3THDH (0xA02Bh) TK3 Threshold Register H R/W (0x00)	93
TK3PUD (0xA02Ch) TK3 DC Pull-Up/Pull-Down Control Register H R/W (0x00)	93
19. GPIO Multi-Function Select and Pin Interrupt	94
IOCFG0xx(0xA100h – 0xA10Fh) IO Buffer Output Configuration Registers R/W (0x00) (xx = 00–07, 10–17)	94
IOCFG1 xx(0xA110h – 0xA11Fh) IO Buffer Input Configuration Registers R/W (0x00) (xx = 00–07, 10–17)	94
MFCFGxx (0xA120 – 0xA12Fh) Port Multi-Function Configuration Registers R/W (0x00) (xx = 00–07, 10–17)	95

1. PIN Description and Multifunction Table

SOP-8	TSSOP-16	WQFN-16	NAME	TYPE	ANIO1	ANIO2	PIN DESCRIPTION
1	1	11	VDD	P			Supply Voltage 2.3V to 5.5V
	2	12	RSTN	IO			Active low reset input with internal 5K Ohm pull-up.
2	3	13	P05	IO/A	KEY	ADCA	Port 0.5 I/O with multi-function This pin also supports I2CS SCL for ISP at default.
3	4	14	P04	IO/A	KEY	ADCB	Port 0.4 I/O with multi-function This pin also supports I2CS SDA for ISP at default.
4	5	15	P03	IO/A	KEY	ADCA	Port 0.3 I/O with multi-function
	6	16	P13	IO/A	KEY	CMPTH	Port 1.3 I/O with multi-function
	7	1	P12	IO/A	KEY	CMPD	Port 1.2 I/O with multi-function
	8	2	P11	IO/A	KEY	CMPC	Port 1.1 I/O with multi-function
	9	3	P10	IO/A	KEY	CMPB	Port 1.0 I/O with multi-function
5	10	4	P02	IO/A	KEY	CMPA	Port 0.2 I/O with multi-function
6	11	5	P01	IO/A	KEY	SHIELD	Port 0.1 I/O with multi-function.
	12	6	P07	IO/A	KEY	ADCB	Port 0.7 I/O with multi-function
	13	7	P06	IO/A	KEY	SHIELD	Port 0.6 I/O with multi-function
7	14	8	P00	IO/A	CREF	DAC	Port 0.0 I/O with multi-function Also serves as CREF for touch key controller
	15	9	VDDC	P/O			Internal 1.5V supply Connect to external 1.0uF decoupling capacitor.
8	16	10	VSS	G			VSS

Table 1-1 PIN Description Table

Note: If customers would like to use our CS89XX Touch Key Library software tool, please refer to our IS3XCS89XX Touch Key Library Tool User's Manual before starting your hardware schematics design.

Each GPIO pin can use MFCFG register to select pin functions. The function table is shown as the following table.

MFCFG[4-0]	Function NAME	FUNCTION DESCRIPTION
00000	LOW	This setting will force the output to be logic low state. Actual output depends on OPOL setting in IOCFG register.
00001	GPIO	8051 GPIO port
00010	SCK	SPI SCK input or output depending on SPI MS setting
00011	SDI	SPI SDI input corresponding to MI or SI and depending on SPI MS setting
00100	SDO	SPI SDO output corresponding to MO or SO and depending on SPI MS setting
00101	SSN	SPI SSN input or output depending on SPI MS setting
00110	SSCL	I ² C Slave SCL I/O
00111	SSDA	I ² C Slave SDA I/O
01000	MSCL	I ² C Master SCL I/O
01001	MSDA	I ² C Master SDA I/O
01010	TX1	EUART1 TX output
01011	RX1	EUART1 RX input

MFCFG[4-0]	Function NAME	FUNCTION DESCRIPTION
01100	TX2	EUART2/LIN TX output
01101	RX2	EUART2/LIN RX input
01110	BZ	Buzzer/Melody output
01111	XCLK	External system clock input
10000	T0	Timer 0 input
10001	T1	Timer 1 input
10010	T2	Timer 2 input
10011	IDX	Quadrature Encoder IDX (Index) input
10100	PHA	Quadrature Encoder PHA (Phase A) input
10101	PHB	Quadrature Encoder PHA (Phase B) input
10110	XCAPT	TCC (Timer Compare/Capture) Capture Input
10111	TC	TCC (Timer Compare/Capture) Terminal Count output
11000	CC	TCC (Timer Compare/Capture) Compare Count output
11001	PWM0	PWM Channel 0 output
11010	PWM1	PWM Channel 1 output
11011	PWM2	PWM Channel 2 output
11100	PWM3	PWM Channel 3 output
11101	PWM4	PWM Channel 4 output
11110	PWM5	PWM Channel 5 output
11111	HIGH	This setting will force the output to be logic high state. Actual output depends on OPOL setting in IOCFG register.

Table 1-2 PIN Multifunction Table

**** MFCFG[4-0] default value is 00000 after reset, so the default state is output logic low.

IS32CS8975

2. Memory Map

There is a total of 256 bytes of internal RAM in CS8975, the same as standard 8052. There are a total of 768 bytes of auxiliary RAM allocated in the 8051 extended RAM area at 0x0100h – 0x03FFh. Users can use "MOVX" instructions to access the XRAM.

There is a 16Kx16 embedded Flash memory for code storage. For CPU access (Read-Only), the lower byte is used for actual access, and the upper byte is used for ECC check. The ECC is performed in a nibble base with each nibble in the high byte corresponding to the nibble in the low byte. ECC is capable of one-bit error correction and two-bit error detection for each nibble. This is significantly more robust than 8:5 ECC. ECC check is through hardware and performed automatically. The embedded Flash can also be accessed through Flash controller. The Flash controller allows both read/write access and is always in 16-bit width with no ECC. For erase operations, the page size of the Flash is 512x16. There are two 512x16 IFB blocks in Flash. The first IFB is used for manufacturing and calibration data, and some areas are for user OTP data. The 2nd IFB is open for the user's application with no restriction. Also, there is an 8-byte security key located at the last 8 bytes of user program code for protection from pirate access to information.

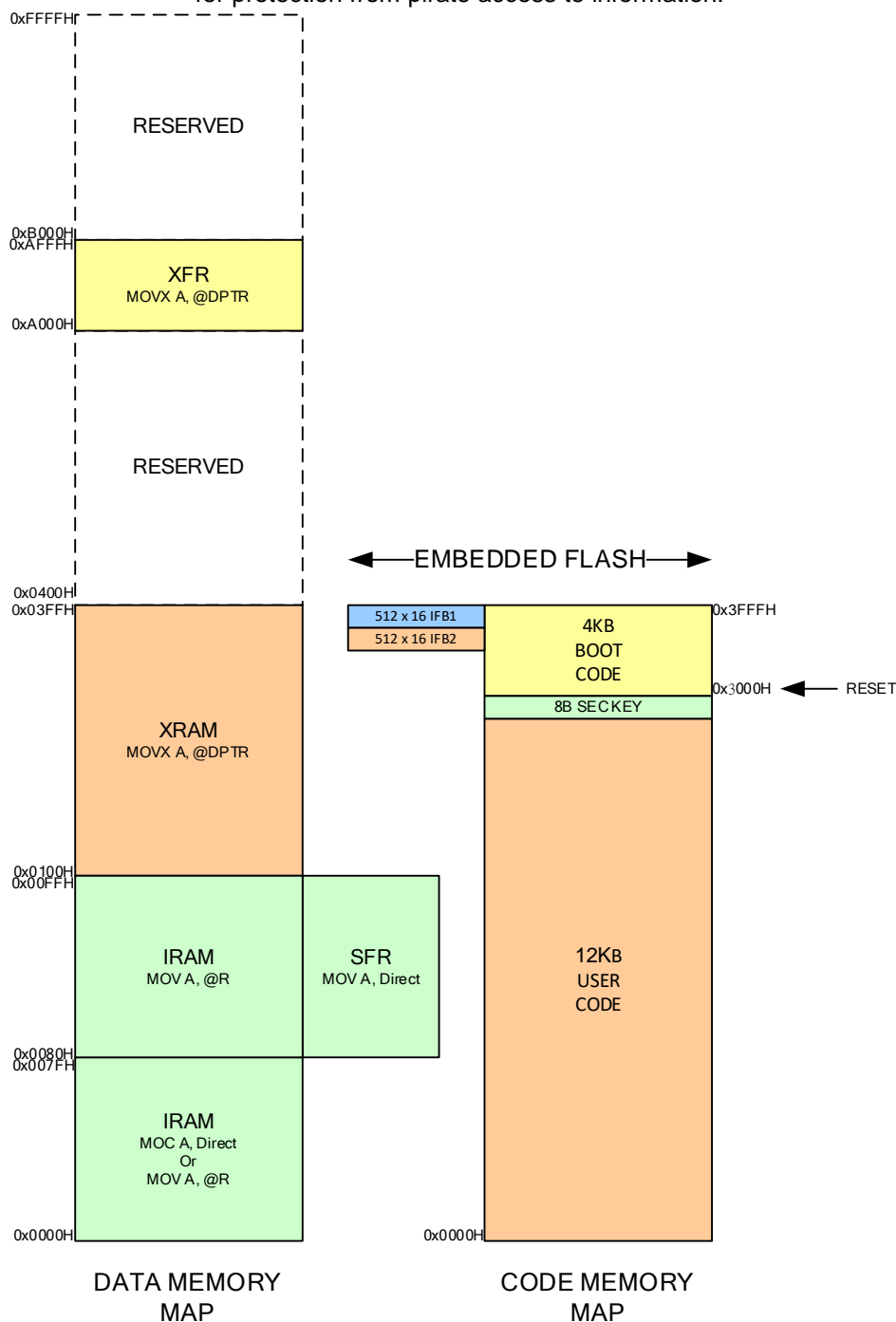

Figure 2-1 Memory Map

IS32CS8975

3. REGISTER MAP SFR (0x80 – 0xFF)

The SFR address map maintains maximum compatibility to most commonly existing 8051-like MCU. The following table shows the SFR address map. Since SFR can be accessed by direct addressing mode, registers of built-in peripherals that require fast access are mostly located in SFR. XFR is mainly used for on-chip peripheral control and configurations.

	0	1	2	3	4	5	6	7
0XF0	B	-			I2CMSA	I2CMCR	I2CMBUF	I2CMTP
0XE0	ACC	-	-	-	-	-	-	-
0XD0	PSW	-	-	-	-	-	-	-
0XC0	-	-	SCON2	I2CMTO	PMR	STATUS	MCON	TA
0XB0	-	SCON1	SCON1X	SFIFO1	SBUF1	SINT1	SBR1L	SBR1H
0XA0	P2	SPICR	SPIMR	SPIST	SPIDATA	SFIFO2	SBUF2	SINT2
0X90	P1	EXIF	WTST	DPX	-	DPX1	-	-
0X80	P0	SP	DPL	DPH	DPL1	DPH1	DPS	PCON
	8	9	A	B	C	D	E	F
0XF8	EXIP	MD0	MD1	MD2	MD3	MD4	MD5	ARCON
0XE8	EXIE		MXAX	-	-	-	-	-
0XD8	WDCON		DPXR	I2CSCON2	I2CSST2	I2CSADR2	I2CSDAT2	-
0XC8	T2CON	TB	RLDL	RLDH	TL2	TH2	ADCCTL	T34CON
0XB8	IP	-	ADCL	ADCH	-	-	-	-
0XA8	IE	ADCCFG	-	-	TL4	TH4	TL3	TH3
0X98			-	ESP	-	ACON	-	WKMASK
0X88	TCON	TMOD	TL0	TL1	TH0	TH1	CKCON	CKSEL

Table 3-1 SFR Register map

4. **TA protected REGISTER MAP XFR (0xA000 – 0xAFFF)**

	0	1	2	3	4	5	6	7
A000	REGTRM	IOSCITRM	IOSCVTRM	-	-	-	-	SOSCTRIM
A010	LVDCFG	LVDTHD	LVDHYS	-	TSTMON	FLSHVDD	BSTCMD	RSTCMD
A020	FLSHDATL	FLSHDATH	FLSHADL	FLSHADH	FLSHECC	FLSHCMD	ISPCLKF	FLSHPRTC
A030	FLSHPRTO	FLSHPRT1	FLSHPRT2	FLSHPRT3	FLSHPRT4	FLSHPRT5	FLSHPRT6	FLSHPRT7
A040	NTAFRQL	NTAFRQH	NTADUR	NTAPAU	NTBFRQL	NTBFRQH	NTBDUR	NTBPAU
A050	TCCFG1	TCCFG2	TCCFG3	-	TCPRDL	TCPRDH	TCCMPL	TCCMPH
A060	TCCPTRL	TCCPTRH	TCCPTFL	TCCPTFH	-	-	-	-
A070	QECFG1	QECFG2	QECFG3	-	QECNTL	QECNTH	QEMAXL	QEMAXH
	8	9	A	B	C	D	E	F
A008	-	-	-	-	-	PECCCFG	PECCADL	PECCADH
A018	TK3CFGA	TK3CFGB	TK3CFGC	TK3CFGD	TK3HDTYL	TK3HDTYH	TK3LDTYL	TK3LDTYH
A028	TK3BASEL	TK3BASEH	TK3THDL	TK3THDH	TK3PUD	DECCCFG	DECCADL	DECCADH
A038	CMPCFGAB	CMPCFGCD	CMPVTH0	CMPVTH1	DACCFG	CMPST	-	-
A048	BZCFG	NTPOW	NTTU	-	-	-	-	-
A058	-	-	-	-	-	-	-	-
A068	T5CON	TL5	TH5	TT5	-	-	-	-
A078	CCCFG	-	-	-	CCDATA0	CCDATA1	CCDATA2	CCDATA3

	0	1	2	3	4	5	6	7
A080	PWMCFG1	PWMCFG2	PWMCFG3	-	PWM0DTYL	PWM0DTYH	PWM1DTYL	PWM1DTYH
A090	LINCTRL	LINCNTRH	LINCNTRL	LINSBRH	LINSBRL	LININT	LININTEN	-
A0A0	-	-	-	-	-	-	-	-
A0B0	LINTCON	TXDTOL	TXDTH	RXDTOL	RXDTH	BSDCLRL	BSDCLRH	BSDWKC
A0C0	-	-	-	-	-	-	-	-
A0D0	-	-	-	-	-	-	-	-
A0E0	BPINTF	BPINTE	BPINTC	BPCTRL	-	-	-	-
A0F0	PC1AL	PC1AH	PC1AT	-	PC2AL	PC2AH	PC2AT	-
	8	9	A	B	C	D	E	F
A088	PWM2DTYL	PWM2DTYH	PWM3DTYL	PWM3DTYH	PWM4DTYL	PWM4DTYH	PWM5DTYL	PWM5DTYH
A098	DBPCIDL	DBPCIDH	DBPCIDT	DBPCNXL	DBPCNXH	DBPCNXT	STEPCTRL	SI2CDBGID
A0A8	-	-	-	-	-	-	-	-
A0B8	BSDACT	-	-	-	-	-	-	-
A0C8	-	-	-	-	-	-	-	-
A0D8	WDT2CF	WDT2L	WDT2H	WDT3CF	WDT3L	WDT3H	-	-
A0E8	-	-	-	-	-	-	-	-
A0F8	-	-	-	-	-	-	-	-

	0	1	2	3	4	5	6	7
A100	IOCFG000	IOCFG001	IOCFG002	IOCFG003	IOCFG004	IOCFG005	IOCFG006	IOCFG007
A110	IOCFG100	IOCFG101	IOCFG102	IOCFG103	IOCFG104	IOCFG105	IOCFG106	IOCFG107
A120	MFCFG00	MFCFG01	MFCFG02	MFCFG03	MFCFG04	MFCFG05	MFCFG06	MFCFG07
A130								
A140								
A150								
A160	-	-	-	-	-	-	-	-
A170	-	-	-	-	-	-	-	-
	8	9	A	B	C	D	E	F
A108	IOCFG010	IOCFG011	IOCFG012	IOCFG013	IOCFG014	IOCFG015	IOCFG016	IOCFG017
A118	IOCFG110	IOCFG111	IOCFG112	IOCFG113	IOCFG114	IOCFG115	IOCFG116	IOCFG117
A128	MFCFG10	MFCFG11	MFCFG12	MFCFG13	MFCFG14	MFCFG15	MFCFG16	MFCFG17
A138	-	-	-	-	-	-	-	-
A148	-	-	-	-	-	-	-	-
A158	-	-	-	-	-	-	-	-
A168	-	-	-	-	-	-	-	-
A178	-	-	-	-	-	-	-	-

Table 4-1 TA protected REGISTER MAP

IS32CS8975

5. 8051 CPU

5.1 CPU Register

ACC (0xE0) Accumulator R/W (0x00)

	7	6	5	4	3	2	1	0
RD	ACC[7-0]							
WR	ACC[7-0]							

ACC is the CPU accumulator register and is involved in direct operations of many instructions. ACC is bit addressable.

B (0xF0) B Register R/W (0x00)

	7	6	5	4	3	2	1	0
RD	B[7-0]							
WR	B[7-0]							

B register is used in standard 8051 multiplication and division instructions and is also used as an auxiliary register for temporary storage. B register is also bit addressable.

PSW (0xD0) Program Status Word R/W (0x00)

	7	6	5	4	3	2	1	0
RD	CY	AC	F0	RS1	RS0	OV	UD	P
WR	CY	AC	F0	RS1	RS0	OV	UD	P

CY	Carry Flag
AC	Auxiliary Carry Flag (BCD Operations)
F0	General Purpose Flag 0
RS1, RS0	Register Bank Select
OV	Overflow Flag
UD	User Defined (reserved)
P	Parity Flag

SP (0x81) Stack Pointer R/W (0x00)

	7	6	5	4	3	2	1	0
RD	SP[7-0]							
WR	SP[7-0]							

PUSH will result in ACC pointed to SP+1 address. POP will load ACC value from IRAM with the address of SP.

ESP (0x9B) Extended Stack Pointer R/W (0x00)

	7	6	5	4	3	2	1	0
RD	ESP[7-0]							
WR	ESP[7-0]							

In FLAT address mode, ESP and SP together form a 16-bit address for stack pointer. ESP holds the higher byte of the 16-bit address.

STATUS (0xC5) Program Status Word RO(0x00)

	7	6	5	4	3	2	1	0
RD	-	HIP	LIP	-				
WR	-	-	-	-	-	-	-	-

HIP	High Priority (HP) Interrupt Status HIP=0 indicates no HP interrupt. HIP=1 indicates HP interrupt progressing.
LIP	Low Priority (LP) Interrupt Status LIP=0 indicates no LP interrupt.

LIP=1 indicates LP interrupt progressing.

Software should check status before entering SLEEP, STOP, IDLE, or PMM modes to prevent loss of intended functions due to delayed entry until these events are finished.

5.2 Addressing Timing and Memory Modes

The clock speed of an MCU with embedded flash memory is usually limited by the access time of on-chip flash memory. With modern process technology, the CPU can operate much faster, and the access time of flash memory is usually around 40 nanoseconds, which becomes a bottleneck of CPU performance. To mitigate this problem, a programmable wait state function is incorporated to allow faster CPU clock to access slower embedded flash memory. The wait state is controlled by WTST register as shown in the following.

WTST (0x92) R/W (0x07)

	7	6	5	4	3	2	1	0
RD	-	-	-	-	WTST3	WTST2	WTST1	WTST0
WR	-	-	-	-	WTST3	WTST2	WTST1	WTST0

WTST[3-0]

Wait State Control register. WTST holds the information about Program Memory access time.

WTST3	WTST2	WTST1	WTST0	Access Time (SYSCLK)
0	0	0	0	0
0	0	0	1	1
0	0	1	0	2
0	0	1	1	3
0	1	0	0	4
0	1	0	1	5
0	1	1	0	6
0	1	1	1	7
1	0	0	0	8
1	0	0	1	9
1	0	1	0	10
1	0	1	1	11
1	1	0	0	12
1	1	0	1	13
1	1	1	0	14
1	1	1	1	15

The default setting of the wait state control register after reset is 0x07. Using a SYSCLK of 4MHz, the WTST can be set to minimum because one clock period is 250ns, which is longer than the typical embedded flash access time. If SYSCLK is above 16MHz, then WTST should be set higher than 1 to allow enough access time. And note that when IOSC is set to 32MHz, WTST[3-0] = 0 is forced to be equivalent as WTST[3-0] = 1.

MCON (0xC6) XRAM Relocation Register R/W (0x00) TA Protected

	7	6	5	4	3	2	1	0
RD	MCON[7-0]							
WR	MCON[7-0]							

MCON holds the starting address of XRAM in 2KB steps. For example, if MCON[7-0]=0x01, the starting address is 0x001000h. MCON is not meaningful in this chip because it only contains on-chip XRAM and MCON should not be modified from 0x00.

The LARGE mode (addressing mode) is compatible with standard 8051 in 16-bit address. FLAT mode extends the program address to 20-bit and expands the stack space to 16-bit data space. The data space is always 16-bit in either LARGE or FLAT mode.

IS32CS8975

ACON (0x9D) R/W (0x00) TA Protected

	7	6	5	4	3	2	1	0
RD	-	-	IVECSEL	-	DPXREN	SA	AM1	AM0
WR	-	-	IVECSEL	-	DPXREN	SA	AM1	AM0

ACON is addressing mode control register.

IVECSEL	Interrupt Vector Selection INTVSEC=1 maps the interrupt vector to 0x3000 space. INTVSEC=0 maps the interrupt vector to normal 0x0000 space.
DPXREN	DPXR Register Control Bit. If DPXREN is 0, "MOVX, @Ri" instruction uses P2 (0xA0) register and XRAM Address [15-8]. If DPXREN is 1, DPXR (0xDA) register and XRAM Address [15-8] are used.
SA	Extended Stack Address Mode Indicator. This bit is read-only. 0 – 8051 standard stack mode where stack resides in internal 256-byte memory. 1 – Extended stack mode. Stack pointer is ESP:SP in 16-bit addressing to data space.
AM1, AM0	AM1 and AM0 Address Mode Control Bits 00 – LARGE address mode in 16-bit 1x – FLAT address mode with 20-bit program address

5.3 MOVX A, @Ri Instructions

DPXR (0xDA) R/W (0x00)

	7	6	5	4	3	2	1	0
RD	DPXR[7-0]							
WR	DPXR[7-0]							

DPXR is used to replace P2[7-0] for high byte of XRAM address bit [15-7] for "MOVX, @Ri" instructions only if DPXREN=1.

MXAX (0xEA) MOVX Extended Address Register R/W (0x00)

	7	6	5	4	3	2	1	0
RD	MXAX[7-0]							
WR	MXAX[7-0]							

MXAX is used to provide top 8-bit address for "MOVX @Ri" instructions only. MXAX does not affect other MOVX instructions.

When accessing XRAM using "MOVX, @DPTR" instruction, the address of XRAM access is formed by DPHi:DPLi depending on which data pointer is selected. Another form of MOVX instruction is "MOVX, @Ri". This instruction provides an efficient programming method to move content within a 256-byte data block. In "@Ri" instruction, the XRAM address [15-7] can be derived from two sources. If ACON.DPXREN = 0, the high address [15-8] is from P2 (0xA0) If ACON.DPXREN = 1, the high address is from DPXR (0xDA) register.

The maximum addressing space of XRAM is up to 16MB, and thus requires 24-bit address. For "MOVX, @DPTR", the XRAMADDR [23-16] is either from DPX (0x93) or DPX1 (0x95) and that depends on which data pointer is selected. For "MOVX, @Ri", the XRAMUADDR [23-16] is from MXAX (0xEA) register.

5.4 Dual Data Pointers and MOVX operations

In standard 8051, there is only one data pointer DPH:DPL to perform MOVX. The enhanced CPU provides 2nd data pointer DPH1:DPL1 to speed up the movement or copy of data block. DPTR is selected by setting DPS (Data Pointer Select) register. Through the control of DPS, efficient programming can be achieved.

DPS (0x86) Data Pointer Select R/W (0x00)

	7	6	5	4	3	2	1	0
RD	ID1	ID0	TSL	-	-	-	-	SEL
WR	ID1	ID0	TSL	-	-	-	-	SEL

ID[1:0] Define the operation of Increment Instruction of DPTR, "INC DPTR". Standard 8051 only has increment DPTR instruction. ID[1-0] changes the definitions of "INC DPTR"

instruction and allows more flexible modifications of DPTR when “INC DPTR” instructions are executed.

ID1	ID0	SEL=0	SEL=1
0	0	INC DPTR	INC DPTR1
0	1	DEC DPTR	INC DPTR1
1	0	INC DPTR	DEC DPTR1
1	1	DEC DPTR	DEC DPTR1

TSL Enable toggling selection of DPTR selection. When this bit is set, the selection of DPTR is toggled when DPTR is used in an instruction and executed.

SEL DPTR selection bit. Set to select DPTR1, and clear to select DPTR. SEL is also decided by the state of ID[1:0] and TSL when DPTR is used in an instruction. When read, SEL reflects the current selection of command.

DPL (0x82) Data Pointer Low R/W (0x00)

	7	6	5	4	3	2	1	0
RD	DPL[7-0]							
WR	DPL[7-0]							

DPL register holds the low byte of data pointer, DPTR.

DPH (0x83) Data Pointer High R/W (0x00)

	7	6	5	4	3	2	1	0
RD	DPH[7-0]							
WR	DPH[7-0]							

DPH register holds the high byte of data pointer, DPTR.

DPL1 (0x84) Extended Data Pointer Low R/W (0x00)

	7	6	5	4	3	2	1	0
RD	DPL1[7-0]							
WR	DPL1[7-0]							

DPL1 register holds the low byte of extended data pointer 1, DPTR1.

DPH1 (0x85) Extended Data Pointer High R/W (0x00)

	7	6	5	4	3	2	1	0
RD	DPH1[7-0]							
WR	DPH1[7-0]							

DPH1 register holds the high byte of extended data pointer 1, DPTR1.

DPX (0x93) Data Pointer Top R/W (0x00)

	7	6	5	4	3	2	1	0
RD	DPX[7-0]							
WR	DPX[7-0]							

DPX is used to provide the top 8-bit address of DPTR when address is above 64KB. The address below 64KB is formed by DPH and DPL. DPX is not applicable in LARGE mode and will form full 24-bit address in FLAT mode. That means auto increment and decrement when DPTR is changed. DPX value has no effect if on-chip data memory is less than 64KB.

DPX1 (0x95) Extended Data Pointer Top R/W (0x00)

	7	6	5	4	3	2	1	0
RD	DPX1[7-0]							
WR	DPX1[7-0]							

DPX1 is used to provide the top 8-bit address of DPTR when address above 64KB. The address below 64KB is formed by DPH1 and DP1L. DPX1 is not applicable in LARGE mode and will form full 24-bit address in Flat mode. That means DPX1 will have auto increment and decrement when DPTR is changed. DPX1 value has no effect if on-chip data memory is less than 64KB.

5.5 Interrupt System

The CPU implements an enhanced Interrupt Control that allows a total of 15 interrupt sources and each with two programmable priority levels. The interrupts are sampled at the rising edge of SYCLK. If interrupts are present and enabled, the CPU enters the interrupt service routine by vectoring to the highest priority interrupt. Among the 15 interrupt sources, 7 of them are from CPU internal integrated peripherals, 6 of them are from on-chip external peripherals, and 2 of them are used for external interrupt sources. When an interrupt is shared, the interrupt service routine must determine which source is requesting the interrupt by examining the corresponding interrupt flag of the sharing peripherals.

The following table shows the interrupt sources and corresponding interrupt vectors. The Flag Reset column shows whether the corresponding interrupt flag is cleared by hardware (self-cleared) or software. Please note the software can only clear the interrupt flag but not set the interrupt flag. The Natural Priority column shows the inherent priority if more than one interrupt is assigned to the same priority level. Please note that the interrupts assigned with higher priority levels always get served first compared with interrupts assigned with lower priority levels regardless of the natural priority.

Interrupt	Peripheral Source Description	Vectors (*Note) IVECSEL=0/1	FLAG RESET	Natural Priority
PINT0	Expanded Pin INT0.x	0x0003/0xX003	Software	1
TF0	Timer 0	0x000B/0xX00B	Hardware	2
PINT1	Expanded Pin INT1.x	0x0013/0xX013	Software	3
TF1	Timer 1	0x001B/0xX01B	Hardware	4
TI0/RI0	EUART1	0x0023/0xX023	Software	5
TF2	Timer 2	0x002B/0xX02B	Software	6
TI2/RI2	EUART2/LIN/LIN_FAULT	0x0033/0xX033	Software	7
I2CM	I ² C Master	0x003B/0xX03B	Software	8
INT2	LVT	0x0043/0xX043	Software	9
INT3	Touch Key/ACMP	0x004B/0xX04B	Software	10
INT4	ADC	0x0053/0xX053	Software	11
WDIF	Watchdog WDT1	0x005B/0xX05B	Software	12
INT6	PWM/TCC/QE	0x0063/0xX063	Software	13
INT7	SPI/ I ² C Slave	0x006B/0xX06B	Software	14
INT8	T3/T4/T5/BZ	0x0073/0xX073	Software	15
ECC	PECC/DECC/WDT2	0x007B/0xX07B	Software	0
BKP	Break Point	0xX080	Software	0
DBG	I ² CS Debug	0xX0C0	Software	0

Table 5-1 Interrupt sources and interrupt vectors

* Note: When IVECSEL=1, the interrupt vector is relocated to the top available 4KB memory space for boot code. Therefore, X value is based on the MCU embedded flash size like X=F, for 64K, X=B for 48K, X=7 for 32K, and X=3 for 16K flash size. In addition to the 15 peripheral interrupts, there are two highest priority interrupts associated with debugging and breakpoint. DBG interrupt is generated when I²C slave is configured as a debug port and a debug request from the host matches the debug ID. BKP interrupt is generated when breakpoint match condition occurs. DBG has a higher priority than BKP. The BKP and DBG interrupts are not affected by the global interrupt enable, EA bit of IE register (0xA8).

The interrupt-related registers are listed in the following tables. Each interrupt can be individually enabled or disabled by setting or clearing the corresponding bit in IE, EXIE, and integrated peripherals' control registers.

IS32CS8975

IE (0xA8) Interrupt Enable Register R/W (0x00)

	7	6	5	4	3	2	1	0
RD	EA	ES2	ET2	ES0	ET1	PINT1EN	ET0	PINT0EN
WR	EA	ES2	ET2	ES0	ET1	PINT1EN	ET0	PINT0EN

EA	Global Interrupt Enable bit
ES2	LIN-capable 16550-like UART2 Interrupt Enable bit
ET2	Timer 2 Interrupt Enable bit
ES0	eUART1 Interrupt Enable bit
ET1	Timer 1 Interrupt Enable bit
PINT1EN	Pin PINT1.x Interrupt Enable bit
ET0	Timer 0 Interrupt Enable bit
PINT0EN	Pin PINT0.x Interrupt Enable bit

EXIE (0xE8) Extended Interrupt Enable Register R/W (0x00)

	7	6	5		4	3	2	1	0
RD	EINT8	EINT7	EINT6		EWDI	EINT4	EINT3	EINT2	EI2CM
WR	EINT8	EINT7	EINT6		EWDI	EINT4	EINT3	EINT2	EI2CM

EINT8	INT8 Interrupt Enable bit
EINT7	INT7 Interrupt Enable bit
EINT6	INT6 Enable bit
EWD1	Watchdog Timer Interrupt Enable bit
EINT4	INT4 Interrupt Enable bit
EINT3	INT3 Interrupt Enable bit
EINT2	INT2 Interrupt Enable bit
EI2CM	I ² C Master Interrupt Enable bit

Each interrupt can be individually assigned to either high or low priority. When the corresponding bit is set to 1, it indicates it is of high priority.

IP (0xB8) Interrupt Priority Register R/W (0x00)

	7	6	5	4	3	2	1	0
RD	-	PS2	PT2	PS0	PT1	PX1	PT0	PX0
WR	-	PS2	PT2	PS0	PT1	PX1	PT0	PX0

PS2	LIN-capable 16550-like UART2 Priority bit
PT2	Timer 2 Priority bit
PS0	eUART1 Priority bit
PT1	Timer 1 Priority bit
PX1	Pin Interrupt INT1 Priority bit
PT0	Timer 0 Priority bit
PX0	Pin Interrupt INT0 Priority bit

EXIP (0xF8) Extended Interrupt Priority Register R/W (0x00)

	7	6	5	4	3	2	1	0
RD	EINT8	EINT7	EINT6	EWDI	EINT4	EINT3	EINT2	EI2CM
WR	EINT8	EINT7	EINT6	EWDI	EINT4	EINT3	EINT2	EI2CM

EINT8	INT8 Priority bit
EINT7	INT7 Priority bit
EINT6	INT6 Priority bit
EWDI	Watchdog Priority bit
EINT4	INT4 Priority bit
EINT3	INT3 Priority bit
EINT2	INT2 Priority bit
EI2CM	I ² C Master Priority bit

EXIF (0x91) Extended Interrupt Flag R/W (0x00)

	7	6	5	4	3	2	1	0
RD	INT8F	INT7F	INT6F	-	INT4F	INT3F	INT2F	I2CMIF
WR	-	-	-	-	-	-	-	I2CMIF

INT8F INT8 Flag bit
 INT7F INT7 Flag bit
 INT6F INT6 Flag bit
 INT4F INT4 Flag bit
 INT3F INT3 Flag bit
 INT2F INT2 Flag bit
 I2CMIF I²C Master Interrupt Flag bit. This bit must be cleared by software.
 Note: Writing to INT2F and INT8F has no effect.

The interrupt flag of internal peripherals is stored in the corresponding flag registers in the peripheral and EXIF registers. These peripherals include T0, T1, T2, and WDT1. Software needs to clear the corresponding flag located in the peripherals (T0, T1, T2, and WDT1). For I2CM, the interrupt flag is in the EXIF register bit I2CMIF. This needs to be cleared by software.

INT2 to INT8 is used to connect to the external peripherals. INT2F to INT8F is the direct equivalent of the interrupt flag from the corresponding peripherals. These peripherals include I2Cs, ADC, etc.

WKMASK (0x9F) R/W (0xFF) Wake Up Mask Register TB Protected

	7	6	5	4	3	2	1	0
RD	WEINT8	WEINT7	WEINT6	WEINT4	WEINT3	WEINT2	WEPINT1	WEPINT0
WR	WEINT8	WEINT7	WEINT6	WEINT4	WEINT3	WEINT2	WEPINT1	WEPINT0

WEINT8 Set this bit to allow INT8 to trigger the wake-up of CPU from STOP modes.
 WEINT7 Set this bit to allow INT7 to trigger the wake-up of CPU from STOP modes.
 WEINT6 Set this bit to allow INT6 to trigger the wake-up of CPU from STOP modes.
 WEINT4 Set this bit to allow INT4 to trigger the wake-up of CPU from STOP modes.
 WEINT3 Set this bit to allow INT3 to trigger the wake-up of CPU from STOP modes.
 WEINT2 Set this bit to allow INT2 to trigger the wake-up of CPU from STOP modes.
 WEPINT1 Set this bit to allow INT1 to trigger the wake-up of CPU from STOP modes.
 WEPINT0 Set this bit to allow INT0 to trigger the wake-up of CPU from STOP modes.

WKMASK register defines the wake-up control of the interrupt signals from the STOP mode. The wake-up is performed by these interrupts and is turned on if the internal oscillator is enabled, and then SYSCLK resumes. The interrupt can be set as a level trigger or an edge trigger and the wake-up is always triggered according to the edge trigger. Please note the wake-up control is wired separately from the interrupt logic, therefore, after waking up, the CPU does not necessarily enter the interrupt service routine if the corresponding interrupt is not enabled. In this case, the CPU continues onto the next instruction, which initiates the STOP mode. Extra attention should be exerted to the modes of exit and re-entry to ensure proper operation.

Please note that all clocks are stopped in STOP mode, and therefore, peripherals requiring clock such as I²C slave, EUART1, EUART2, ADC, LVD, and T3 cannot perform the wake-up function. Only external pins and peripherals that do not require a clock can be used for wakeup purposes. Such peripherals are like an analog comparator and GPIO.

PINT0 and PINT1 are used for external GPIO pin Interrupts. All GPIO pins can be enabled to generate the PINT0 or PINT1 depending on its MFCFG register setting. Each GPIO pin also contains the rising/falling edge detections and either one or both edges can be used for interrupt triggering. The same GPIO pin can be used to generate a wake-up event.

TCON (0x88) R/W (0x00)

	7	6	5	4	3	2	1	0
RD	TF1	TR1	TF0	TR0	PINT1F	-	PINT0F	-
WR	-	TR1	-	TR0	PINT1F	-	PINT0F	-

TF1 Timer 1 Interrupt Flag bit. TF1 is cleared by hardware when entering the interrupt routine.
 TR1 Timer 1 Run Control bit. Set to enable Timer 1.

TF0	Timer 0 Interrupt Flag. TF0 is cleared by hardware when entering the interrupt routine.
TR0	Timer 0 Run Control bit. Set to enable Timer 0.
PINT1F	Pin INT1 Interrupt Flag bit. PINT1F is cleared by hardware when entering the interrupt routine.
PINT0F	Pin INT0 Interrupt Flag bit. PINT0F is cleared by hardware when entering the interrupt routine.

5.6 Register Access Control

One important feature of the embedded MCU is its reliable operations in a harsh environment. Many system failures result from the accidental loss of data or changes of critical registers that may lead to catastrophic effects. The CPU provides several protection mechanisms, which are described in this section.

TA (0xC7) Time Access A Control Register2 WO xxxxxx0

	7	6	5	4	3	2	1	0
RD	-	-	-	-	-	-	-	TASTAT
WR	TA Register							

TA access control emulates a ticket that must be purchased before modifying a critical register. To modify or write into a TA protected register, TA must be accessed in a predefined sequence to obtain the ticket. The ticket is used when an intended modification operation is done to the TA protected register. To obtain the next access a new ticket must be obtained again by performing the same predefined sequence on TA. TA does not limit the read access of the TA protect registers. The TA protected register includes WDCON (0xD8), MCON (0xC6), and ACON (0x9D) registers. The following predefined sequences are required to modify the content of MCON.

```
MOV TA, #0xAA;
MOV TA, #0x55;
MOV MCON, #0x01;
```

Once access is granted, there is no time limitation of the access. The access is voided if any operation is performed in TA address. When read, TASTAT indicates whether TA is locked or not (1 indicates “unlock” and 0 indicates “lock”).

TB (0xC9) Time Access B Control Register2 RW (0x00)

	7	6	5	4	3	2	1	0
RD	-	-	-	-	-	-	-	TBSTAT
WR	TB Register							

TB access control functions are similar to TA control, except the ticket is for multiple uses with a time limit. Once access is granted, the access is open for 256 clock periods and then expires. The software can read TB address to obtain the current TB status. The TB protected registers are marked on the register names and descriptions. To modify registers with TB protection, the following procedure must be performed.

```
MOV TB, #0xAA
MOV TB, #0x55
```

This action creates a timed window of 256 SYSCLK periods to allow write access of these TB protected registers. If the above sequence is repeated before the 128 cycles expires, a new 128 cycles is extended. The current 256 cycles can be terminated immediately by writing #0x00 to TB registers, such as

```
MOV TB, #0x00
```

It is recommended to terminate the TB access window once the user’s program finishes the modifications of TB protected registers.

Because TA and TB are critical reassurance of the reliable operation of the MCU that prevents accidental hazardous uncontrollable modifications of critical registers, the operation of these two registers should bear extreme cautions. It is strongly advised that these two registers should be turned on only when needed. Both registers use synchronous CPU clock, therefore, it is imperative that any running tasks of TA and TB should be terminated before entering IDLE mode or STOP mode. Both modes turn off the CPU clock. If TA and TB are enabled, they stay enabled until the CPU clock resumes, and thus may create vulnerabilities for critical registers.

Another reliability concern of embedded Flash MCU is that the important content in the Flash can be accidentally erased. This concern is addressed by the content protection in the Flash controller.

5.7 Clock Control and Power Management Modes

This section describes the clock control and power-saving modes of the CPU and its integrated peripherals. The settings are controlled by PCON (0x87) and PMR (0xC4) registers. The register description is defined as follows.

PCON (0x87) R/W (0x00)

	7	6	5	4	3	2	1	0
RD	SMOD0	-	-	-	-	-	-	-
WR	SMOD0	-	-	-	-	SLEEP	STOP	IDLE

SMOD0 UART0 Baud Rate Control. This is used to select double baud rate in mode 1, 2 or 3 for UART0 using Timer 1 overflow. This definition is the same as standard 8051.
This implementation does not support UART 0

SLEEP Sleep Mode Control Bit. When this bit and the Stop bit are set to 1, the clock of the CPU and all peripherals are disabled and enter SLEEP mode. The SLEEP mode exits when non-clocked interrupts or resets occur. Upon exiting SLEEP mode, the Sleep bit and Stop bit in PCON is automatically cleared. In terms of power consumption, the following relationship applies: IDLE mode > STOP mode > SLEEP mode. SLEEP mode is the same as STOP mode, except it also turns off the band gap and the regulator. It uses a very low power back-up regulator (< 5uA). When waking up from SLEEP mode, it takes a longer time (< 64 IOSC clock cycles) compared with STOP mode because the regulator requires more time to stabilize.

STOP Stop Mode Control Bit. The clock of the CPU and all peripherals is disabled and enters STOP mode if the Sleep bit is cleared. The STOP mode can only be terminated by non-clocked interrupts or resets. Upon exiting STOP mode, the Stop bit in PCON is automatically cleared.

IDLE Idle Bit. If the IDLE bit is set, the system goes into IDLE mode. In Idle mode, CPU clock becomes inactive and the CPU and its integrated peripherals such as WDT, T0/T1/T2, and UART0 are reset. But the clocks of external peripherals and CPU like ADC, LIN-capable 16550-like EUART1, EUART2, SPI, T3, I²C slave and the others are still active. This allows the interrupts generated by these peripherals and external interrupts to wake up the CPU. The exit mechanism of IDLE mode is the same as STOP mode. The Idle bit is automatically cleared upon the exit of the IDLE mode.

PMR (0xC4) R/W (010xxxxx)

	7	6	5	4	3	2	1	0
RD	CD1=0	CD0	SWB	-	-	-	-	-
WR	-	CD0	SWB	-	-	-	-	-

CD1, CD0 Clock Divider Control. These two bits control the entry of PMM mode. When CD0=1, and CD1=0, full speed operation is in effect. When CD0=1, and CD1=1, the CPU enters PMM mode where CPU and its integrated peripherals operate at a clock rate divided by 257. Note that in PMM mode, all integrated peripherals such as UART0, LIN-capable 16550-like UART2, WDT1, and T0/T1/T2 run at this reduced rate, and thus may not function properly. All external peripherals activities with CPU still operate at full speed in PMM mode.

NOTE: CD1 is internally hardwired to 0. The device does not support PMM mode.

SWB Switch Back Control bit. Setting this bit allows the actions to occur in integrated peripherals to automatically switch back to normal operation mode.

NOTE: PMM mode is not supported.

CKSEL (0x8F) System Clock Selection Register R/W (0x0C) TB Protected

	7	6	5	4	3	2	1	0
RD	IOSCDIV[3-0]				-	-	CLKSEL[1]	CLKSEL[0]
WR	IOSCDIV[3-0]				REGRDY[1]	REGRDY[0]	CLKSEL[1]	CLKSEL[0]

IOSCDIV[3-0] IOSC Pre-Divider. Default is IOSC/32.

IOSCDIV[3-0]	SYSCLK
0	IOSC
1	IOSC/2
2	IOSC/4
3	IOSC/6
4	IOSC/8
5	IOSC/10
6	IOSC/12
7	IOSC/14
8	IOSC/16
9	IOSC/32
10	IOSC/64
11	IOSC/128
12	IOSC/256
13	IOSC/256
14	IOSC/256
15	IOSC/256

REGRDY[1-0]

Wake up delay time for main regulator stable time from reset or from sleep mode wakeup. Default is the longest delay at 256 SOSC32KHz.

REGRDY[1]	REGRDY[0]	Delay time
0	0	8 SOSC32KHz cycle
0	1	16 SOSC32KHz cycle
1	0	64 SOSC32KHz cycle
1	1	256 SOSC32KHz cycle

CLKSEL[1-0]

Clock Source Selection

These two bits define the clock source of the system clock SYSCLK. The selections are shown in the following table. The default setting after reset is IOSC.

CLKSEL[1]	CLKSEL[0]	SYSCLK
0	0	IOSC (through divider)
0	1	SOSC32KHz
1	0	IOSC (through divider)
1	1	XCLKIN

WKMASK (0x9F) R/W (0xFF) Wake-Up Mask Register TB Protected

	7	6	5	4	3	2	1	0
RD	WEINT8	WEINT7	WEINT6	WEINT4	WEINT3	WEINT2	WEPINT1	WEPINT0
WR	WEINT8	WEINT7	WEINT6	WEINT4	WEINT3	WEINT2	WEPINT1	WEPINT0

- WEINT8 Set this bit to allow INT8 to trigger the wake-up of CPU from STOP modes.
- WEINT7 Set this bit to allow INT7 to trigger the wake-up of CPU from STOP modes.
- WEINT6 Set this bit to allow INT6 to trigger the wake-up of CPU from STOP modes.
- WEINT4 Set this bit to allow INT4 to trigger the wake-up of CPU from STOP modes.
- WEINT3 Set this bit to allow INT3 to trigger the wake-up of CPU from STOP modes.
- WEINT2 Set this bit to allow INT2 to trigger the wake-up of CPU from STOP modes.
- WEPINT1 Set this bit to allow INT1 to trigger the wake-up of CPU from STOP modes.
- WEPINT0 Set this bit to allow INT0 to trigger the wake-up of CPU from STOP modes.

WKMASK register defines the wakeup control of the interrupt signals from the STOP/SLEEP mode. The wake-up is

performed by these interrupts and is turned on if the internal oscillator is enabled, and then SYSCLK resumes. The interrupt can be set as a level trigger or an edge trigger and the wake-up always is triggered according to the edge trigger. Please note the wake-up control is wired separately from the interrupt logic, and therefore after waking up, the CPU does not necessarily enter the interrupt service routine if the corresponding interrupt is not enabled. In this case, the CPU continues onto the next instruction, which initiates the STOP/SLEEP mode. Extra attention should be exerted to the modes of exit and re-entry to ensure proper operation.

Please note that all clocks are stopped in STOP/SLEEP mode, and therefore peripherals requiring clock such as I²C slave, EUART1, EUART2, ADC, LVD, and T3/T4 cannot perform the wake-up function. Only external pins and peripherals that do not require a clock can be used for wakeup purposes. The peripherals are LIN Wakeup and Timer5 with SOSC32kHz.

5.7.1 IDLE Mode

IDLE mode provides power saving by stopping SYSCLK of CPU and its integrated peripherals while other peripherals are still in operation with SYSCLK. Hence other peripherals can still function normally and generate interrupts that wake up the CPU from IDLE mode. The IDLE mode is enabled by setting IDLE bit to 1.

When the CPU is in idle mode, no processing is possible. All integrated internal peripherals such as T0/T1/T2, EUART1, LIN-capable 16550-like EUART2 and I²C Master are inaccessible during IDLE mode. The IDLE mode can be exited by hardware reset through RSTN pin (8 pin CS8975 doesn't have RSTN pin) or by external interrupts as well as the interrupts from external peripherals that are OR-ed with the external interrupts. The triggering external interrupts need to be enabled properly. Upon exiting from IDLE mode, the CPU resumes operation as the clock is turned on. CPU immediately vectors to the interrupt service routine of the corresponding interrupt sources that wake up the CPU. When the interrupt service routine is complete, RETI returns to the program and immediately follows the one that invokes the IDLE mode. Upon returning from IDLE mode to normal mode, the idle bit in PCON is automatically cleared.

5.7.2 STOP Mode

STOP mode provides further power reduction by stopping SYSCLK of all circuits. At STOP mode, IOSC oscillator is disabled. STOP mode is entered by setting STOP=1. To achieve minimum power consumption, it is essential to turn off all peripherals with DC current consumption. It is also important that the software switches to the IOSC clock and disables all other clock generators before entering STOP mode. This is critical to ensure a smooth transition when resuming its normal operations. Upon entering STOP mode, the system uses the last edge of IOSC clock to shut down the IOSC clock generator.

Valid interrupt/wakeup event or reset will result in the exit of STOP mode. Upon exit, STOP bit is cleared by hardware and IOSC is resumed. Then CPU resumes the normal operation with previous clock settings. When an interrupt occurs, the CPU immediately vectors to the interrupting service routine of the corresponding interrupt source. When the interrupt service routine is complete, RETI returns to the program immediately to execute the instruction that following the instruction that invokes the STOP mode.

The on-chip 1.5V regulator for core circuits is still enabled along with its reference voltage. As a result, the power consumption due to the regulator and its reference circuit is still at around 100uA to 200uA. The advantage of STOP mode is its immediate resumption of the CPU.

5.7.3 SLEEP Mode

SLEEP mode achieves very low standby consumption by putting the on-chip 1.5V regulator in disabled state. An ultra-low power 1.3V backup regulator supplies the internal core circuit and maintains the logic state and SRAM data. The total current drain in SLEEP mode is less than 1uA for typical conditions. Only the backup regulator and the SOSC32KHz circuit are still in operation during SLEEP mode.

The exit of SLEEP mode is the same interrupt/wakeup event as in STOP mode, and in addition the on-chip regulator is enabled after a delay time set by REGRDY (clocked by SOSC32KHz), and SYSCLK is resumed. REGRDY delay is necessary to ensure stable operation of the regulator. A longer delay should be set for a larger decoupling capacitance.

5.7.4 Clock Control

The clock selection is defined by CKSEL register (0x8F). There are three selections from divided IOSC or SOSC32KHz or XCLKIN. The default selection is divided IOSC. Typical power consumption of CPU is 0.15mA/MHZ.

5.8 Watchdog Timer

The Watchdog Timer is a 30-bit timer that can be used by a system supervisor or as an event timer. The Watchdog timer can be used to generate an interrupt or to issue a system reset depending on the control settings. This section describes the register related to the operation of Watchdog Timer and its functions. The following

diagram shows the structure of the Watchdog Timer. Note WDT1 shares the same clock with the CPU, and thus WDT1 is disabled in IDLE mode or STOP mode. But it runs at a reduced rate in PMM mode.

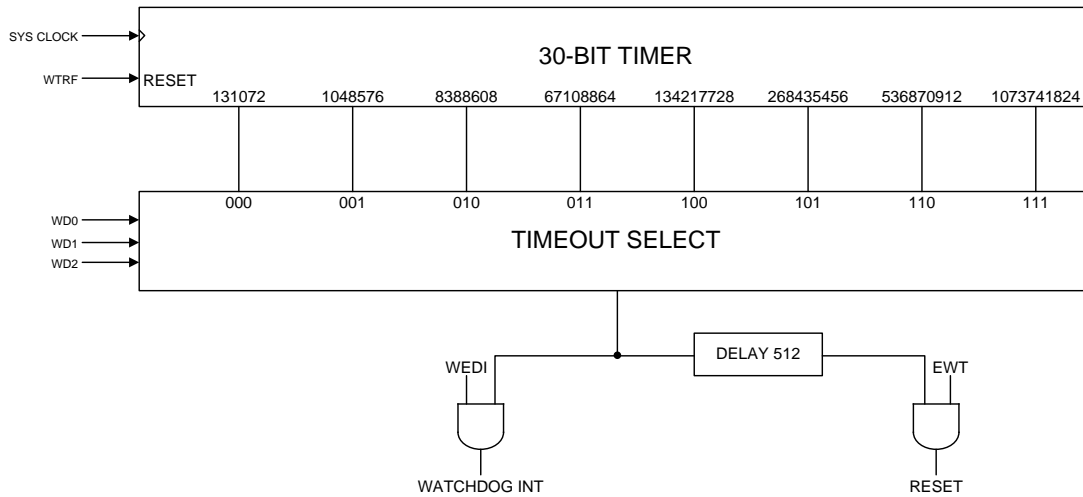

Figure 5-1 Watchdog Timer block diagram

WDCON (0xD8) WDT1 Interrupt Flag Register R/W (0x02) TA Protected for WDT1CLR bit only

	7	6	5	4	3	2	1	0
RD	-	-	-	-	WDT1IF	WDT1RF	WDT1REN	-
WR	-	-	-	-	WDT1IF	WDT2RF	WDT1REN	WDT1CLR

- WDT1IF** WDT1 Interrupt Flag bit. This bit is set when the session expires regardless of whether a WDT1 interrupt is enabled or not. Note the WDT1 interrupt enable control is in EXIE (0xE8).4 EWDI bit. It must be cleared by software.
- WDT1RF** WDT1 Reset Flag bit. WDT1RF is cleared by hardware reset including RSTN, POR etc. WDT1RF is set to 1 after a WDT1 reset occurs. It can be cleared by software. WDT1RF can be used by software to determine if a WDT1 reset has occurred.
- WDT1REN** WDT1 Enable bit. Set this bit to enable the watchdog reset function. The default WDT1 reset is enabled and WDT1 timeout is set to maximum.
- WDT1CLR** Reset the Watchdog timer 1. Writing 1 to WDT1CLR resets the WDT1 timer. WDT1CLR bit is not a register and does not hold any value. The clearing action of Watchdog timer is protected by TA access. In another word, to clear Watchdog timer 1, TA must be unlocked and then followed by writing WDT1CLR bit to 1. If TA is still locked, the program can write 1 into WDT1CLR bit, but it does not reset the Watchdog timer.

CKCON (0x8E) Clock Control and WDT1 R/W (0xC7)

	7	6	5	4	3	2	1	0
RD	WD1	WD0	T2CKDCTL	T1CKDCTL	T0CKDCTL	WD2	-	-
WR	WD1	WD0	T2CKDCTL	T1CKDCTL	T0CKDCTL	WD2	-	-

- T2CKDCTL** Timer 2 Clock Source Division Factor Control Flag. Writing 1 to this bit sets the Timer 2 division factor to 4, the Timer 2 clock frequency equals to CPU clock frequency divided by 4. Setting this bit to 0 (the default power-on value) sets the Timer 2 division factor to 12, and the Timer 2 clock frequency equals to CPU clock frequency divided by 12.
- T1CKDCTL** Timer 1 Clock Source Division Factor Control Flag. Writing 1 to this bit sets the Timer 1 division factor to 4, and the Timer 1 clock frequency equals to CPU clock frequency divided by 4. Writing 0 (the default power-on value) to this bit sets the Timer 1 division factor to 12, and the Timer 1 clock frequency equals to CPU clock frequency divided by 12.
- T0CKDCTL** Timer 0 Clock Source Division Factor Control Flag. Writing 1 to this bit sets the Timer 0 division factor to 4, and the Timer 0 clock frequency equals to CPU clock frequency divided by 4. Writing 0 (the default power-on value) to this bit sets the Timer 0 division factor equals to 12, and the Timer 0 clock frequency equals to CPU clock frequency divided by 12.

WD[2-0]

This register controls the time out value of WDT1 as the following table. The time out value is shown as follows and the default is set to maximum value:

WD2	WD1	WD0	Time Out Value
0	0	0	131072
0	0	1	1048576
0	1	0	8388608
0	1	1	67108864
1	0	0	134217728
1	0	1	268435456
1	1	0	536870912
1	1	1	1073741824

A second 16-bit Watchdog Timer (WDT2) clocked by the independent nonstop SOSC32KHz is included. WDT2 can be used to generate interrupt/wakeup timing from STOP/SLEEP mode, or generate software reset.

WDT2CF (0xA0D8h) Watchdog Timer 2 Configure Registers R/W (0xA7) TB Protected

	7	6	5	4	3	2	1	0
RD	-	WDT2REN	WDT2RF	WDT2IEN	WDT2CS[2-0]			WDT2IF
WR	WDT2CLR	WDT2REN	WDT2RF	WDT2IEN	WDT2CS[2-0]			WDT2IF

WDT2CLR

WDT2 Counter Clear

WDT2REN

Writing "1" to WDT2CLR clears the WDT2 count to 0. It is self-cleared by hardware.

WDT2 Reset Enable

WDT2RF

WDT2REN=1 configures WDT2 to perform software reset.

WDT2 Reset Flag

WDT2IEN

WDT2RF is set to "1" after a WDT2 reset occurs. This must be cleared by software by writing "0".

WDT2 Interrupt Enable

WDT2CS[2-0]

WDT2IEN=1 enables WDT2 interrupt.

WDT2 Clock Scaling

WDT2CS[2-0]	Clock SOSC32KHz Divider	WDT2Period
000	2 ⁸	8 msec
001	2 ⁸	8 msec
010	2 ⁸	8 msec
011	2 ⁸	8 msec
100	2 ¹²	128 msec
101	2 ¹³	256 msec
110	2 ¹⁴	512 msec
111	2 ¹⁵	1024 msec

WDT2IF

WDT2 Interrupt Flag

WDT2IF is set to "1" after a WDT2 interrupt. This must be cleared by software by writing "0".

Please note the longest effective time WDT2 can be set is approximately 18 hours.

WDT2L (0xA0D9h) Watchdog Timer 2 Time Out Value Low Byte RW (0xFF) TB Protected

	7	6	5	4	3	2	1	0
RD	WDT2CNT[7-0]							
WR	WDT2[7-0]							

IS32CS8975

WDT2H (0xA0DAh) Watchdog Timer 2 Time Out Value High Byte RW (0x0F) TB Protected

	7	6	5	4	3	2	1	0
RD	WDT2CNT[15-8]							
WR	WDT2[15-8]							

WDT2L and WDT2H hold the time out value for watchdog timer 2. When the counter reaches WDT2 time out value, an interrupt or a reset is generated. Reading this register returns the current count value.

A third Watchdog Timer (WDT3) is also included for further enhancement of fault recovery. WDT3 cannot be disabled in normal mode. It can be disabled only in SLEEP mode if SLEEPDIS[2-0] = 3'b101. WDT3 is 4 times slower than WDT2, and is also set by WDT2CS[2-0].

WDT2CS[2-0]	Clock SOSC32KHz Divider	WDT3 Period
000	2 ⁸	8 msec
001	2 ⁸	8 msec
010	2 ⁸	8 msec
011	2 ⁸	8 msec
100	2 ¹²	128 msec
101	2 ¹³	256 msec
110	2 ¹⁴	512 msec
111	2 ¹⁵	1024 msec

Therefore, the longest time of WDT3 is about 4 second times 2¹⁶ equaling approximately 72 hours.

WDT3CF (0xA0DBh) Watchdog Timer 3 Configure Registers R/W (0xD1) TB Protected

	7	6	5	4	3	2	1	0
RD	-	SLEEPDIS[2-0]			-			WDT3RF
WR	WDT3CLR	SLEEPDIS[2-0]			-			WDT3RF

WDT3CLR WDT3 Counter Clear

Writing "1" to WDT3CLR clears the WDT3 count to 0. It is self-cleared by hardware.

SLEEPDIS[2-0] Stop WDT3 increment in STOP/SLEEP mode.

SLEEPDIS[2-0]=3b'101 stops WDT3 in STOP/SLEEP mode.

Note: This function has been removed.

WDT3RF WDT3 Reset Flag

WDT3RF is set to "1" after a WDT3 reset occurs. This must be cleared by software by writing "0".

WDT3L (0xA0DCh) Watchdog Timer 3 Time Out Value Low Byte RO R/W (0xFF) TB Protected

	7	6	5	4	3	2	1	0
RD	WDT3CNT[7-0]							
WR	WDT3[7-0]							

WDT3H (0xA0DDh) Watchdog Timer 3 Time Out Value High Byte RO R/W (0x0F) TB Protected

	7	6	5	4	3	2	1	0
RD	WDT3CNT[15-8]							
WR	WDT3[15-8]							

WDT3L and WDT3H hold the time out value for watchdog timer 3. When the counter reaches WDT3 time out value, a reset is generated. Reading this register returns the current count value.

5.9 System Timers – T0 and T1

The CPU contains three 16-bit timers/counters, Timer 0, Timer 1 and Timer 2. In timer mode, Timer 0, Timer 1 registers are incremented every 12 SYSCLK period when the appropriate timer is enabled. In timer mode, Timer 2 registers are incremented every 12 or 2 SYSCLK period (depending on the operating mode). In counter mode,

IS32CS8975

the timer registers are incremented every falling edge on their corresponding inputs: T0, T1, and T2. These inputs are read every SYCLK period.

Timer 0 and Timer 1 are fully compatible with the standard 8051. Timers 0 and 1 are controlled by TCON (0x88) and TMOD (0x89) registers while each timer consists of two 8-bit registers TH0 (0x8C), TL0 (0x8A), TH1 (0x8D), TL1 (0x8B).

TCON (0x88) R/W (0x00)

	7	6	5	4	3	2	1	0
RD	TF1	TR1	TF0	TR0	PINT1F	-	PINT0F	-
WR	-	TR1	-	TR0	PINT1F	-	PINT0F	-

TF1	Timer 1 Interrupt Flag bit. TF1 is cleared by hardware when entering the interrupt routine.
TR1	Timer 1 Run Control bit. Set to enable Timer 1.
TF0	Timer 0 Interrupt Flag. TF0 is cleared by hardware when entering the interrupt routine.
TR0	Timer 0 Run Control bit. Set to enable Timer 0.
PINT1F	Pin INT1 Interrupt Flag bit. PINT1F is cleared by hardware when entering the interrupt routine.
PINT0F	Pin INT0 Interrupt Flag bit. PINT0F is cleared by hardware when entering the interrupt routine.

TMOD (0x89h) Timer 0 and 1 Mode Control Register R/W (0x00)

	7	6	5	4	3	2	1	0
RD	GATE1	CT1	T1M1	T1M0	GATE0	CT0	T0M1	T0M0
WR	GATE1	CT1	T1M1	T1M0	GATE0	CT0	T0M1	T0M0

GATE1	Timer 1 Gate Control bit. Set to enable external T1 to function as gate control of the counter.
CT1	Counter or Timer Mode Select bit. Set CT1 to use external T1 as the clock source. Clear CT1 to use internal clock.
T1M1	Timer 1 Mode Select bit.
T1M0	Timer 1 Mode Select bit.
GATE0	Timer 0 Gate Control bit. Set to enable external T0 to function as gate control of the counter.
CT0	Counter or Timer Mode Select bit. Set CT0 to use external T0 as the clock source. Clear CT0 to use internal clock.
T0M1	Timer 0 Mode Select bit.
T0M0	Timer 0 Mode Select bit.

M1	M0	Mode	Mode Descriptions
0	0	0	TL functions as a 5-bit pre-scaler and TH functions as an 8-bit counter/timer. They form a 13-bit operation.
0	1	1	TH and TL are cascaded to form a 16-bit counter/timer.
1	0	2	TL functions as an 8-bit counter/timer and is auto-reloaded from TH.
1	1	3	TL functions as an 8-bit counter/timer. TH functions as an 8-bit timer, which is controlled by GATE1. Only Timer 0 can be configured in Mode 3. When this happens, Timer 1 can only be used when its interrupt is not required.

5.9.1 Mode 0

In this mode, TL functions as a 5-bit pre-scaler and TH functions as an 8-bit counter/timer. Both form a 13-bit counter/timer. The Mode 0 operation is shown in the following diagram.

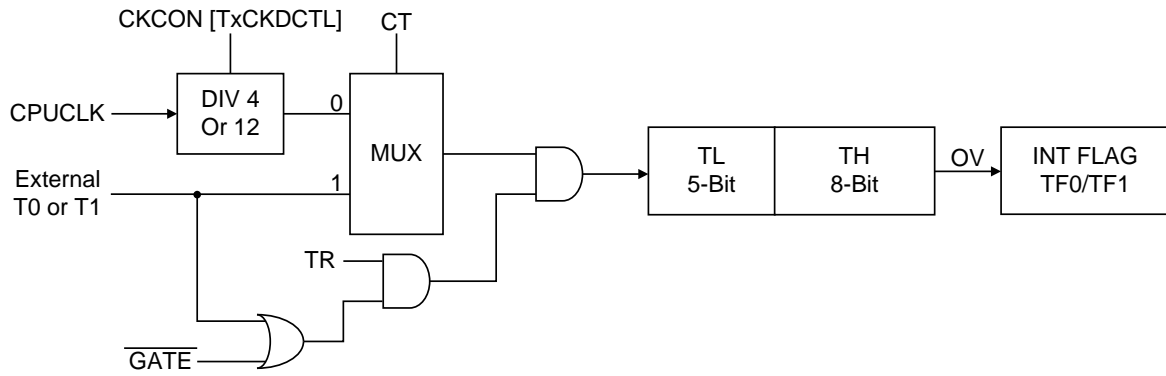

Figure 5-2 Timer/Counter Mode 0: 13-bit counter

5.9.2 Mode 1

Mode 1 operates the similar way as Mode 0 does, except TL is configured as 8-bit and thus forming a 16-bit counter/timer. This is shown in the following diagram.

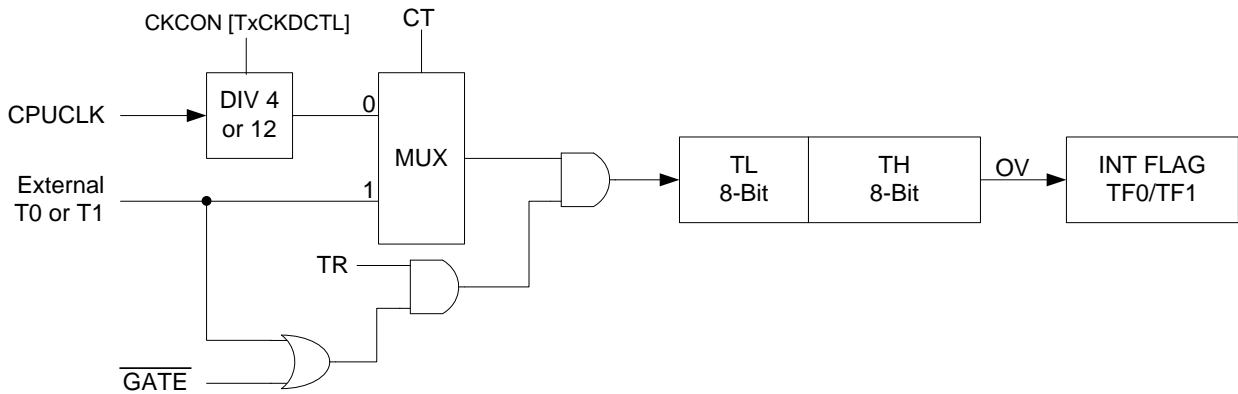

Figure 5-3 Timer/Counter Mode 1: 16-bit counter

5.9.3 Mode 2

Mode 2 configures the timer as an 8-bit re-loadable counter. The counter is TL while TH stores the reload data. The reload occurs when TL overflows. The operation is shown in the following diagram:

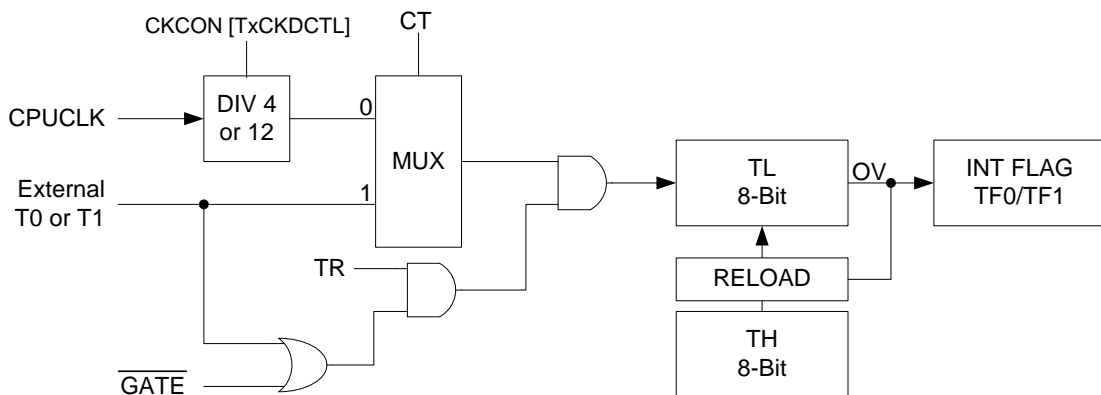

Figure 5-4 Timer/Counter Mode 2: 8-bit re-load

5.9.4 Mode 3

Mode 3 is a special mode for Timer 0 only. In this mode, Timer 0 is configured as two separate 8-bit counters. TL uses the control and interrupt flags of Timer 0, whereas TH uses control and interrupt flag of Timer 1. Since Timer 1's control and flag are occupied, Timer 2 can only be used for counting purposes such as Baud rate generator while Timer 0 is in Mode 3. The operation flow of Mode 3 is shown in the following diagram.

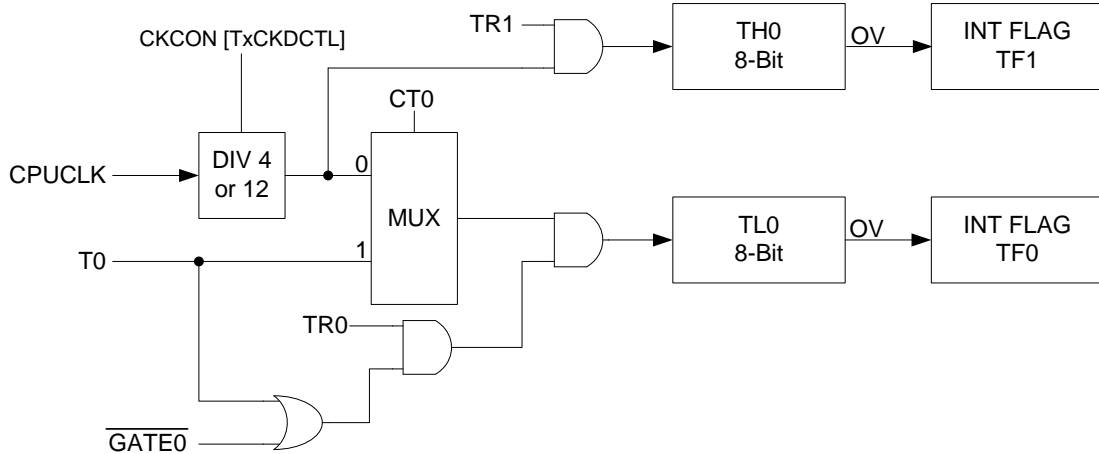

Figure 5-5 Timer/Counter Mode 3: Two 8-bit counters

TL0 (0x8Ah) Timer 0 Low Byte Register R/W (0x00)

	7	6	5	4	3	2	1	0
RD	TL0[7-0]							
WR	TL0[7-0]							

TH0 (0x8Ch) Timer 0 High Byte Register 0 R/W (x00)

	7	6	5	4	3	2	1	0
RD	TH0[7-0]							
WR	TH0[7-0]							

TL1 (0x8Bh) Timer 1 Low Byte Register 0 R/W (0x00)

	7	6	5	4	3	2	1	0
RD	TL1[7-0]							
WR	TL1[7-0]							

TH1 (0x8Dh) Timer 1 High Byte Register 0 R/W (0x00)

	7	6	5	4	3	2	1	0
RD	TH1[7-0]							
WR	TH1[7-0]							

5.10 System Timer – T2

Timer 2 is fully compatible with the standard 8052 timer 2. Timer 2 can be used as the re-loadable counter, capture timer, or baud rate generator. Timer 2 uses five SFR as counter registers, capture registers and a control register.

T2CON (0xC8h) Timer 2 Control and Configuration Register R/W (0x00)

	7	6	5	4	3	2	1	0
RD	TF2	EXF2	RCLK	TCLK	EXEN2	TR2	CT2	CPRL2
WR	TF2	EXF2	RCLK	TCLK	EXEN2	TR2	CT2	CPRL2

- TF2 Timer 2 Interrupt Flag bit.
TF2 must be cleared by software. TF2 is not set when RCLK or TCLK is set (It means Timer 2 is used as an UART0 Baud rate generator.).
- EXF2 T2EX Falling Edge Flag bit.
This bit is set when T2EX has a falling edge when EXEN2=1. EXF2 must be cleared by software.
- RCLK Receive Clock Enable bit.
1 – UART0 receiver is clocked by Timer 2 overflow pulses.
0 – UART0 receiver is clocked by Timer 1 overflow pulses.

IS32CS8975

TCLK	Transmit Clock Enable bit. 1 – UART0 transmitter is clocked by Timer 2 overflow pulses. 0 – UART0 transmitter is clocked by Timer 1 overflow pulses.
EXEN2	T2EX Function Enable bit. 1 – Allows capture or reload as T2EX falling edge appears. 0 – Ignore T2EX events.
TR2	Start/Stop Timer 2 Control bit. 1 – Start 0 – Stop
CT2	Timer 2 Timer/Counter Mode Select bit. 1 – External event counter uses T2 pin as the clock source. 0 – Internal clock timer mode
CPRL2	Capture/Reload Select bit. 1 – Use T2EX pin falling edge for capture 0 – Automatic reload on Timer 2 overflow or falling edge of T2EX (when EXEN2=1). If RCLK or TCLK is set (Timer 2 is used as a baud rate generator), this bit is ignored and an automatic reload is forced on Timer 2 overflows.

Note: This implementation does not support UART0

Timer 2 can be configured for three modes of operations – Auto-reload Counter, Capture Timer, and Baud Rate Generator. These modes are defined by RCLK, TCLK, CPRL2 and TR2 bits of T2CON registers. The definition is illustrated in the following table:

RCLK or TCLK	CPRL2	TR2	Mode Descriptions
0	0	1	16-bit Auto-reload Counter mode. Timer 2 overflow sets the TF2 interrupt flag and TH2/TL2 is reloaded with RLDH/RLDL register.
0	1	1	16-bit Capture Timer mode. Timer 2's overflow sets TF2 interrupt flag. When EXEN2=1, TH2/TL2 content is captured into RLDH/RLDL when T2EX falling edge occurs.
1	X	1	Baud Rate Generator mode. Timer 2's overflow is used for configuring UART0.
X	X	0	Timer 2 is stopped.

The block diagram of the Timer 2 operating in Auto-reload Counter and Capture Timer modes are shown in the following diagram. Please note External T2 and External T2EX are tied together in this product.

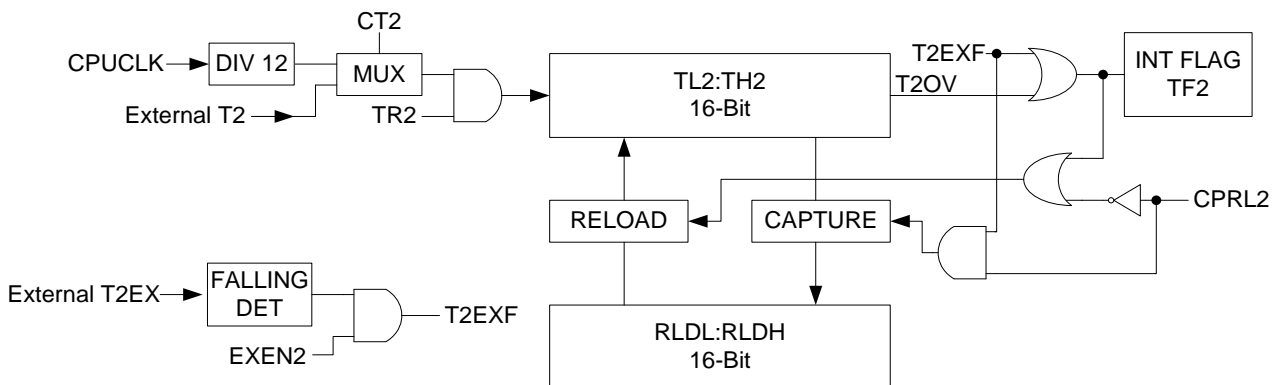

Figure 5-6 Timer 2 block diagram of Auto-reload and Capture

The block diagram of the Timer 2 operating in Baud Rate Generator is shown in the following diagram:

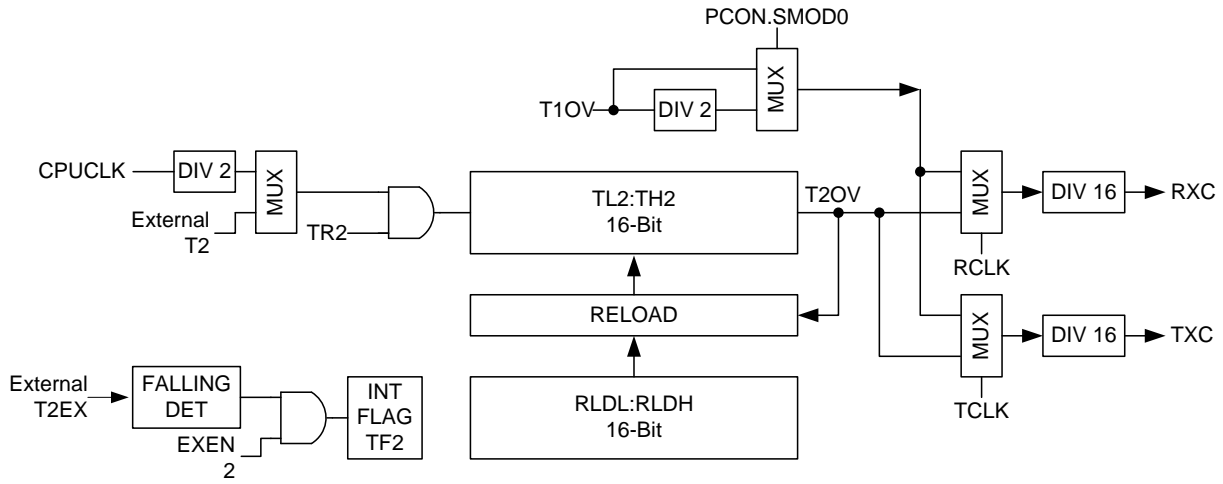

Figure 5-7 Timer 2 block diagram of Baud Rate Generator

TL2 (0xCCh) Timer 2 Low Byte Register 0 R/W (0x00)

	7	6	5	4	3	2	1	0
RD	TL2[7-0]							
WR	TL2[7-0]							

TH2 (0xCDh) Timer 2 High Byte Register 0 R/W (0x00)

	7	6	5	4	3	2	1	0
RD	TH2[7-0]							
WR	TH2[7-0]							

RLDL (0xCAh) Timer 2 reload Low Byte Register 0 R/W (0x00)

	7	6	5	4	3	2	1	0
RD	RLDL[7-0]							
WR	RLDL[7-0]							

RLDH (0xCBh) Timer 2 reload High Byte Register 0 R/W (0x00)

	7	6	5	4	3	2	1	0
RD	RLDH[7-0]							
WR	RLDH[7-0]							

5.11 System Timer – T3 and T4

Both Timer 3 and Timer 4 are simple 16-Bit reload timers or free-run counters and are clocked by the system clock. The block diagram is shown below.

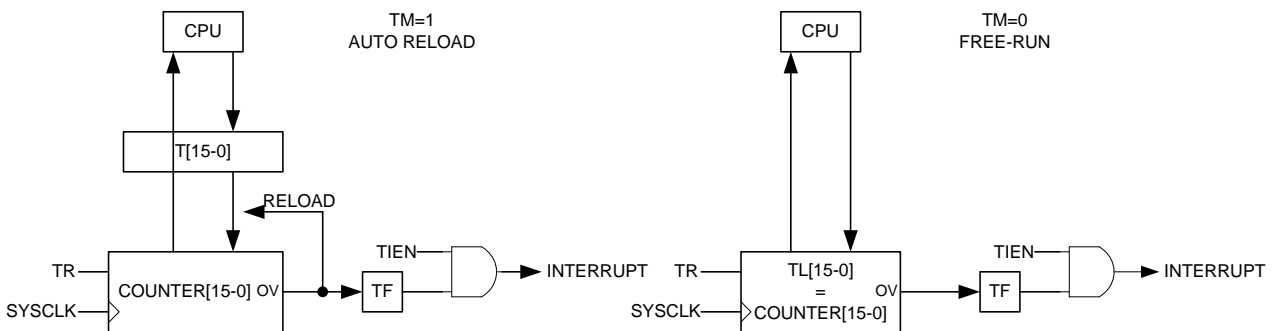

Figure 5-8 Timer 3 and Timer 4 block diagram

IS32CS8975

T34CON (0xCFh) Timer 3 and Timer 4 Control and Status Register R/W (00000000)

	7	6	5	4	3	2	1	0
RD	TF4	TM4	TR4	T4IEN	TF3	TM3	TR3	T3IEN
WR	TF4	TM4	TR4	T4IEN	TF3	TM3	TR3	T3IEN

TF4	Timer 4 Overflow Interrupt Flag bit. TF4 is set by hardware when overflow condition occurs. TF4 must be cleared by software.
TM4	Timer 4 Mode Control bit. TM4 = 1 set timer 4 as auto reload, and TM4=0 set timer 4 as free run.
TR4	Timer 4 Run Control bit. Set to enable Timer 4, and clear to stop Timer 4.
T4IEN	Timer 4 Interrupt Enable bit. T4IEN=0 disable the Timer 4 overflow interrupt. T4IEN=1 enable the Timer 4 overflow interrupt.
TF3	Timer 3 Overflow Interrupt Flag bit. TF3 is set by hardware when overflow condition occurs. TF3 must be cleared by software.
TM3	Timer 3 Mode Control bit. TM3 = 1 sets timer 3 as auto reload, and TM3=0 sets timer 3 as free run.
TR3	Timer 3 Run Control bit. Set to enable Timer 3, and clear to stop Timer 3.
T3IEN	Timer 3 Interrupt Enable bit. T3IEN=0 disable Timer 3 overflow interrupt. T3IEN=1 enable Timer 3 overflow interrupt.

TL3 (0xAEh) Timer 3 Low Byte Register 0 R/W 00000000

	7	6	5	4	3	2	1	0
RD	T3[7-0]							
WR	T3[7-0]							

TH3 (0xAFh) Timer 3 High Byte Register 0 R/W 00000000

	7	6	5	4	3	2	1	0
RD	T3[15-8]							
WR	T3[15-8]							

TL4 (0xACh) Timer 4 Low Byte Register 0 R/W 00000000

	7	6	5	4	3	2	1	0
RD	T4[7-0]							
WR	T4[7-0]							

TH4 (0xADh) Timer 4 High Byte Register 0 R/W 00000000

	7	6	5	4	3	2	1	0
RD	T4[15-8]							
WR	T4[15-8]							

T3[15-0] and T4[15-0] function differently for read or write operation. When set in auto-reload mode, its reload value register is written, and in free-run mode, the counter value is written immediately. When read, the return value is always the present counter value. There is no snapshot buffer in the read operation, so software should always read the high byte then the low byte.

5.12 System Timer – T5

T5 is a 24-Bit simple timer. It can select four different clock sources and can be used for extended sleep mode wakeup. The clock sources include IOSC, XOSC, RTC and SOSC32KHz. T5 can be configured either as free-run mode or auto-reload mode. Timer 5 does not depend on the SYSCLK, and therefore it continues to count under STOP or SLEEP mode if the clock source is present. The following diagram shows the block diagram of Timer 5.

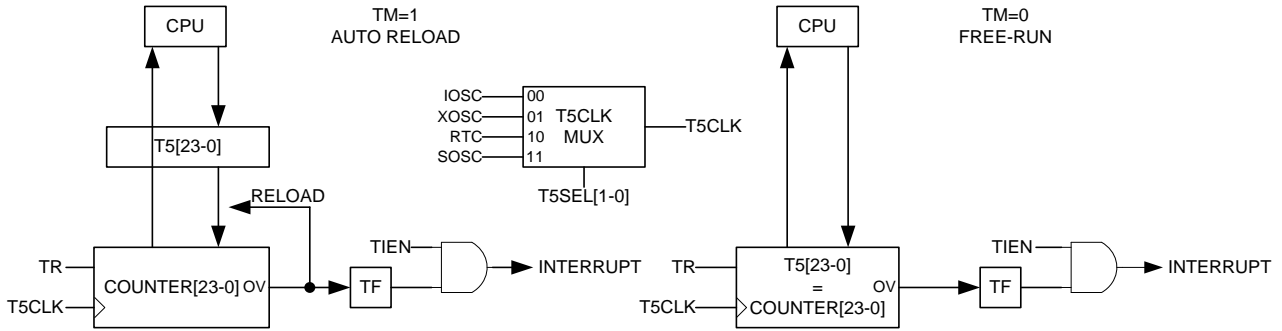

Figure 5-9 Timer 5 block diagram

T5CON (0xA068h) Timer 5 Control and Status Register R/W (00000000)

	7	6	5	4	3	2	1	0
RD	TF5	T5SEL[1]	T5SEL[0]	TM5	TR5	-	-	T5IEN
WR	TF5	T5SEL[1]	T5SEL[0]	TM5	TR5	-	-	T5IEN

- TF5** Timer 5 Overflow Interrupt Flag bit
TF5 is set by hardware when overflow condition occurs. TF5 must be cleared by software.
- T5SEL[1-0]** Timer 5 Clock Selection bits
T5SEL[1-0] = 00, IOSC
T5SEL[1-0] = 01, IOSC
T5SEL[1-0] = 10, SOSC32KHz
T5SEL[1-0] = 11, SOSC32KHz
- TM5** Timer 5 Mode Control bit. TM5=1 sets timer 5 as auto reload, and TM5=0 sets timer 5 as free run.
- TR5** Timer 5 Run Control bit. Set to enable Timer 5, and clear to stop Timer 5.
- T5IEN** Timer 5 Interrupt Enable bit.
T5IEN=0 disable the Timer 5 overflow interrupt.
T5IEN=1 enable the Timer 5 overflow interrupt.

TL5 (0xA069) Timer5 Low Byte Register 0 R/W (0x00)

	7	6	5	4	3	2	1	0
RD	T5[7-0]							
WR	T5[7-0]							

TH5 (0xA06A) Timer5 Medium Byte Register 0 R/W (0x00)

	7	6	5	4	3	2	1	0
RD	T5[15-8]							
WR	T5[15-8]							

TT5 (0xA06B) Timer5 High Byte Register 0 R/W (0x00)

	7	6	5	4	3	2	1	0
RD	T5[23-16]							
WR	T5[23-16]							

T5[23-0] functions differently for read or write operation. When set in auto-reload mode, its reload value register is written; and in free-run mode, the counter value is written immediately. When read, the return value is always the present counter value. There is no snapshot buffer in the read operation, so software should always read the high byte and then the low byte.

5.13 Multiplication and Division Unit (MDU)

MDU provides acceleration on unsigned integer operations of 16-bit multiplications, 32-bit division, shifting and normalizing operations. The following table shows the execution characteristics of these operations. The MDU does not contain the operation completion status flag. Therefore, the most efficient utilization of MDU uses NOP

IS32CS8975

delay for the required clock time of the MDU operation types. The number of clock cycles required for each operation is shown in the following table and it is counted from the last write of the writing sequence.

Operations	Result	Reminder	# of Clock Cycle
32-bit division by 16-bit	32-bit	16-bit	17
16-bit division by 16-bit	16-bit	16-bit	9
16-bit multiplication by 16-bit	32-bit	-	10
32-bit normalization	-	-	3 – 20
32-bit shift left/right	-	-	3 – 18

The MDU is accessed through MD0 to MD5 that contains the operands and the results, and the operation is controlled by ARCON register.

ARCON (0xFF) MDU Control R/W (0x00)

	7	6	5	4	3	2	1	0
RD	MDEF	MDOV	SLR	SC4	SC3	SC2	SC1	SC0
WR	MDEF	MDOV	SLR	SC4	SC3	SC2	SC1	SC0

- MDEF MDU Error Flag bit. Set by hardware to indicate MDx being written before the previous operation completes. MDEF is automatically cleared after reading ARCON.
- MDOV MDU Overflow Flag bit. MDOV is set by hardware if dividend is zero or the result of multiplication is greater than 0x0000FFFFh.
- SLR Shift Direction Control bit. SLR = 1 indicates a shift to the right and SLR =0 indicates a shift to the left.
- SC4-0 Shift Count Control and Result bit. If SC0-4 is written with 00000, the normalization operation performed by MDU. When the normalization is completed, SC4-0 contains the number of shift performed in the normalization. If SC4-0 is written with a non-zero value, the shift operation is performed by MDU with the number of shift specified by SC4-0 value.

MD0 (0xF9) MDU Data Register 0 R/W (0x00)

	7	6	5	4	3	2	1	0
RD	MD0[7-0]							
WR	MD0[7-0]							

MD1 (0xFA) MDU Data Register 1 R/W (0x00)

	7	6	5	4	3	2	1	0
RD	MD1[7-0]							
WR	MD1[7-0]							

MD2 (0xFB) MDU Data Register 2 R/W (0x00)

	7	6	5	4	3	2	1	0
RD	MD2[7-0]							
WR	MD2[7-0]							

MD3 (0xFC) MDU Data Register 3 R/W (0x00)

	7	6	5	4	3	2	1	0
RD	MD3[7-0]							
WR	MD3[7-0]							

MD4 (0xFD) MDU Data Register 4 R/W (0x00)

	7	6	5	4	3	2	1	0
RD	MD4[7-0]							
WR	MD4[7-0]							

IS32CS8975

MD5 (0xFE) MDU Data Register 5 R/W (0x00)

	7	6	5	4	3	2	1	0
RD	MD5[7-0]							
WR	MD5[7-0]							

MDU operation consists of three phases.

1. Load MD0 to MD5 data registers in an appropriate order depending on the operation.
2. Execution of the operations
3. Read result from MD0 to MD5 registers.

The following list shows the MDU read and write sequences. Each operation has its unique writing sequence and reading sequence of MD0 to MD5 registers, and therefore a precise access sequence is required.

5.13.1 Division – 32-bit divide by 16-bit or 16-bit divide by 16-bit

Follow the following write-sequence. The first write of MD0 resets the MDU and initiates the MDU error flag mechanism. The last write will result in the calculation of MDU.

Write MD0 with Dividend LSB byte

Write MD1 with Dividend LSB+1 byte

Write MD2 with Dividend LSB+2 byte (ignore this step for 16-bit divide by 16-bit)

Write MD3 with Dividend MSB byte (ignore this step for 16-bit divide by 16-bit)

Write MD4 with Divisor LSB byte

Write MD5 with Divisor MSB byte

Then follow the following read-sequence. The last read prompts MDU for the next operations.

Read MD0 with Quotient LSB byte

Read MD1 with Quotient LSB+1 byte

Read MD2 with Quotient LSB+2 byte (ignore this step for 16-bit divide by 16-bit)

Read MD3 with Quotient MSB byte (ignore this step for 16-bit divide by 16-bit)

Read MD4 with Remainder LSB byte

Read MD5 with Remainder MSB byte

Read ARCON to determine error or overflow condition

Please note if the sequence is violated, the calculation may be interrupted and result in errors.

5.13.2 Multiplication – 16-bit multiply by 16-bit

Follow the following write sequence.

Write MD0 with Multiplicand LSB byte

Write MD4 with Multiplier LSB byte

Write MD1 with Multiplicand MSB byte

Write MD5 with Multiplier MSB byte

Then follow the following read sequence.

Read MD0 with Product LSB byte

Read MD1 with Product LSB+1 byte

Read MD2 with Product LSB+2 byte

Read MD3 with Product MSB byte

Read ARCON to determine error or overflow condition

5.13.3 Normalization – 32-bit

Normalization is obtained with integer variables stored in MD0 to MD3. After normalization, all leading zeroes are removed by shift left operations. To start the normalization operation, SC4-0 in ARCON is first written with 00000. After completion of the normalization, SC4-0 is updated with the number of leading zeroes and the normalized result is restored on MD0 to MD3. The number of the shift of the normalization can be used as exponents. The following write sequence should be followed. The last write to ARCON initiates the normalization operations by MDU.

- Write MD0 with Operand LSB byte
- Write MD1 with Operand LSB+1 byte
- Write MD2 with Operand LSB+2 byte
- Write MD3 with Operand MSB byte
- Write ARCON with SC4-0 = 00000

Then follow the following read sequence.

- Read MD0 with Result LSB byte
- Read MD1 with Result LSB+1 byte
- Read MD2 with Result LSB+2 byte
- Read MD3 with Result MSB byte
- Read SC[4-0] from ARCON for normalization count or error flag

5.13.4 Shift – 32-bit

Shift is done with integer variables stored in MD0 to MD3. To start the shift operation, SC4-0 in ARCON is first written with shift count and SLR with shift direction. After completion of the Shift, the result is stored back to MD0 to MD3. The following write sequence should be followed. The last write to ARCON initiates the normalization operations by MDU.

- Write MD0 with Operand LSB byte
- Write MD1 with Operand LSB+1 byte
- Write MD2 with Operand LSB+2 byte
- Write MD3 with Operand MSB byte
- Write ARCON with SC4-0 = Shift count and SLR with shift direction

Then follow the following read sequence.

- Read MD0 with Result LSB byte
- Read MD1 with Result LSB+1 byte
- Read MD2 with Result LSB+2 byte
- Read MD3 with Result MSB byte
- Read ARCON's for error flag

5.13.5 MDU Flag

The error flag (MDEF) of MDU indicates improperly performed operations. The error mechanism starts at the first MD0 write and finishes with the last read of MD result register. MDEF is set if current operation is interrupted or restarted by improper write of MD register before the operation completes. MDEF is cleared if the operations and proper write/read sequences successfully complete. The overflow flag (MDOV) of MDU indicates an error of operations. MDOV is set if

- The divisor is zero
- Multiplication overflows
- Normalization operation is performed on already normalized variables (Check if MD3 register bit 7 =1)

5.14 I²C Master

The I²C master controller provides the interface to I²C slave devices. It can be programmed to operate with arbitration and clock synchronization to allow it to operate in multi-master configurations. The master uses SCL and

IS32CS8975

SDA pins. The controller contains a built-in 8-bit timer to allow various I²C bus speeds. The maximum I²C bus speed is limited to SYSCLK/12.

I2CMTP (0xF7h) I²C Master Time Period R/W (x00)

	7	6	5	4	3	2	1	0
RD	I2CMTP[7-0]							
WR	I2CMTP[7-0]							

This register sets the frequency of I²C bus clock. If I2CMTP[7-0] is equal to or larger than 0x01, then SCL_FREQ = SYSCLK_FREQ/8/(1 + I2CMTP). If I2CMTP[7-0] = 0x00, SCL_FREQ = SYSCLK_FREQ /12.

I2CMSA (0xF4) I²C Master Slave Address R/W (0x00)

	7	6	5	4	3	2	1	0
RD	SA[6-0]							RS
WR	SA[6-0]							RS

SA[6-0] Slave Address. SA[6-0] defines the slave address which the I²C master uses to communicate.

RS Receive/Send Bit. RS determines if the following operation is to RECEIVE (RS=1) or SEND (RS=0).

I2CMBUF (0xF6) I²C Master Data Buffer Register R/W (0x00)

	7	6	5	4	3	2	1	0
RD	RD[7-0]							
WR	TD[7-0]							

I2CMBUF functions as a transmit-data register for write and as a receive-data register for read. When written, TD is sent to the bus by the next SEND or BURST SEND operations. TD[7] is sent first. When read, RD contains the 8-bit data received from the bus upon the last RECEIVE or BURST RECEIVE operation.

I2CMCR (0xF5) I²C Master Control and Status Register R/W (0x00)

	7	6	5	4	3	2	1	0
RD	-	BUSBUSY	IDLE	ARBLOST	DATANACK	ADDRNACK	ERROR	BUSY
WR	CLEAR	INFILEN	-	HS	ACK	STOP	START	RUN

The I2CMCR register can be written to set control and read back for status.

CLEAR	Reset I ² C Master State Machine Set CLEAR=1 will reset the state machine. CLEAR is self-cleared when reset is completed.
INFILEN	Input Noise Filter Enable. When INFILEN is set, pulses shorter than 50 nsec on inputs of SDA and SCL are filtered out.
IDLE	This bit indicates that I ² C master is in the IDLE mode.
BUSY	This bit indicates that I ² C master is receiving or transmitting data, and other status bits are not valid.
BUSBUSY	This bit indicates that the external I ² C bus is busy and access to the bus is not possible. This bit is set/reset by START and STOP conditions.
ERROR	This bit indicates that an error occurs in the last operation. The errors include slave address was not acknowledged, or transmitted data is not acknowledged, or the master controller loses arbitration.
ADDRNACK	This bit is automatically set when the last transmitted slave address is not acknowledged.
DATANACK	This bit is automatically set when the last transmitted data is not acknowledged.
ARBLOST	This bit is automatically set when the last operation of I ² C master controller loses the bus arbitration.

START, STOP, RUN and HS, RS, ACK bits are used to drive I²C Master to initiate and terminate a transaction. The Start bit generates START, or REPEAT START protocol. The Stop bit determines if the cycle stops at the end of the data cycle or continues to burst. To generate a single read cycle, the designated address is written in SA, and RS is set to 1. ACK=0, STOP=1, START=1, and RUN=1 are set in I2CMCR to perform the operation and then

STOP. When the operation is completed (or aborted due to errors), I2C master generates an interrupt. The ACK bit must be set to 1. This causes the controller to send an ACK automatically after each byte transaction. The ACK bit must be reset when set to 0 when the master operates in receive mode and does not receive further data from the slave devices.

The following table lists the permitted control bits combinations in master IDLE mode.

HS	RS	ACK	STOP	START	RUN	OPERATIONS
0	0	-	0	1	1	START condition followed by SEND. Master remains in transmit mode.
0	0	-	1	1	1	START condition followed by SEND and STOP.
0	1	0	0	1	1	START condition followed by RECEIVE operation with negative ACK. Master remains in RECEIVER mode.
0	1	0	1	1	1	START condition followed by RECEIVE and STOP.
0	1	1	0	1	1	START condition followed by RECEIVE. Master remains in receive mode.
0	1	1	1	1	1	Illegal command
1	0	0	0	0	1	Master Code sending and switching to HS mode

The following table lists the permitted control bits combinations in master TRANSMITTER mode.

HS	RS	ACK	STOP	START	RUN	OPERATIONS
0	-	-	0	0	1	SEND operation. Master remains in TRANSMITTER mode.
0	-	-	1	0	0	STOP condition
0	-	-	1	0	1	SEND followed by STOP condition
0	0	-	0	1	1	REPEAT START condition followed by SEND. Master remains in TRANSMITTER mode.
0	1	-	1	1	1	REPEAT START condition followed by SEND and STOP condition
0	1	0	0	1	1	REPEAT START condition followed by RECEIVE operation with negative ACK. Master remains in TRANSMITTER mode.
0	1	0	1	1	1	REPEAT START condition followed by SEND and STOP condition
0	1	1	0	1	1	REPEAT START condition followed by RECEIVE. Master remains in RECEIVER mode.
0	1	1	1	1	1	Illegal command

The following table lists the permitted control bits combinations in master RECEIVER mode.

HS	RS	ACK	STOP	START	RUN	OPERATIONS
0	-	0	0	0	1	RECEIVE operation with negative ACK. Master remains in RECEIVE mode.
0	-	-	1	0	0	STOP condition
0	-	0	1	0	1	RECEIVE followed by STOP condition
0	-	1	0	0	1	RECEIVE operation. Master remains in RECEIVER mode.
0	-	1	1	0	1	Illegal command
0	1	0	0	1	1	REPEAT START condition followed by RECEIVE operation with negative ACK. Master remains in RECEIVER mode.
0	1	0	1	1	1	REPEAT START condition followed by RECEIVE and STOP conditions
0	1	0	1	1	1	REPEAT START condition followed by RECEIVE. Master remains in RECEIVER mode.

HS	RS	ACK	STOP	START	RUN	OPERATIONS
0	0	-	0	1	1	REPEAT START condition followed by SEND. Master remains in TRANSMITTER mode.
0	0	-	1	1	1	REPEAT START condition followed by SEND and STOP conditions

All other control-bit combinations not included in the above three tables are NOP. In Master RECEIVER mode, STOP should be generated only after data negative ACK is executed by Master or address negative ACK is executed by slave. Negative ACK means SDA is pulled low when the acknowledge clock pulse is generated.

I2CMTO (0xC3) I2C Time Out Control Register R/W (0x00)

	7	6	5	4	3	2	1	0
RD	I2CMTOF	I2CMTO[6-0]						
WR	I2CMTOEN	I2CMTO[6-0]						

I2CMTOEN I2CM Time Out Enable
 I2CMTOF I2CM Time Out Flag
 This bit is set when a time out occurs. It is cleared when I2CM CLEAR command is issued.
 I2CMTO[6-0] I2CM Time Out Setting
 The TO time is set to $(I2CMTO[6-0]+1)*2*BT$. When a time out occurs, an I2CM interrupt will be generated.

5.15 Checksum/CRC Accelerator

To enhance the performance, a hardware Checksum/CRC Accelerator is included and closely coupled with CPU. This provides most used checksum and CRC operation for 8/16/24/32-bit data width. For 8-bit data, one SYSCLK cycle is used, two SYSCLK cycles for 16-bit data, and four SYSCLK cycles for 32-bit.

CCCFG (0xA078h) Checksum/CRC Accelerator Configuration Register R/W (0x00)

	7	6	5	4	3	2	1	0
RD	DWIDTH[1-0]		REVERSE	NOCARRY	SEED	-	-	BUSY
WR	DWIDTH[1-0]		REVERSE	NOCARRY	SEED	CRCMODE[2-0]		

DWIDTH[1-0] Data Input Width
 00 – set input as 8-bit wide
 01 – set input as 16-bit wide
 10 – set the input as 24-bit wide
 11 – set the input as 32-bit wide
 REVERSE Reverse of input MSB/LSB Sequence
 REVERSE=0 is for LSB first operations.
 REVERSE=1 is for MSB first operation.
 The reverse order is based on the data width. For example, if the data width is 32-bit, and REVERSE=1, then CCDATA[0] holds MSB, and CCDATA[31] holds LSB. REVERSE=0 does not affect output result and SEED ordering i.e., CCDATA[31] always holds MSB, CCDATA[0] always holds LSB.
 The following table shows the MSB/LSB relationship.

DWIDTH	REVERSE=0	REVERSE=1
0	CRCIN[7-0] = CCDATA[7-0]	CRCIN[7-0] = CCDATA[0-7]
1	CRCIN[15-0] = CCDATA[15-0]	CRCIN[15-0] = CCDATA[0-15]
2	CRCIN[23-0] = CCDATA[23-0]	CRCIN[23-0] = CCDATA[0-23]
3	CRCIN[31-0] = CCDATA[31-0]	CRCIN[31-0] = CCDATA[0-31]

NOCARRY Carry Setting for Checksum
 NOCARRY=0 use previous carry result for new result.
 NOCARRY=1 discards previous carry result
 SEED Seed Entry
 SEED=1 write the result into CCDATA to become SEED value
 SEED=0 for normal data inputs

Please note, the MSB/LSB ordering of SEED entry from CCDATA is not affected by REVERSE.

CRCMODE[2-0] Defines CRC/Checksum Mode

- 000 – Accelerator is disabled and clock gated is off
- 001 – 8-bit Checksum
- 010 – 32-bit Checksum
- 011 – CRC-16 (IBM 0x8005)
 - $X^{16}+X^{15}+X^2+1$
- 100 – CRC-16 (CCITT 0x1021)
 - $X^{16}+X^{12}+X^5+1$
- 101 – CRC-32 (ANSI 802.3 0x104C11DB7)
 - $X^{32}+X^{26}+X^{23}+X^{22}+X^{16}+X^{12}+X^{11}+X^{10}+X^8+X^7+X^5+X^4+X^2+X+1$
- 110 – Reserved
- 111 – CRC and Checksum Clear

The first step for the programmer is to set the CRCMODE[2-0] for the Checksum or CRC operation and then write “111” to CRCMODE[2-0] to reset the Checksum/CRC states and restore the default seed value (for checksum, seed value=0x00 or 0x00000000, for CRC seed value = 0xFFFF or 0xFFFFFFFF).

BUSY CRC Status

BUSY=1 indicates the results is not yet completed. Since only up to four cycles are used to calculate the Checksum or CRC, there is no need to check BUSY status before the next data entry and read the results.

CCDATA registers are the data I/O port for Checksum/CRC Accelerator. For 8-bit data width only, CCDATA[7-0] should be used. For data width wider than 8-bit, high byte should always be written first. Writing the low byte (CCDATA0) completes the data entry and starts the calculations. When SEED=1, the data been written save to CRC seed value. The SEED value entry bit ordering is not affected by REVERSE setting. The result of accelerator can be directly read out from CCDATA registers and are not affected by REVERSE setting.

CCDATA0 (0xA07Ch) Checksum/CRC Data Register 0 R/W (0x00)

	7	6	5	4	3	2	1	0
RD	CCDATA[7-0]							
WR	CCDATA[7-0]							

CCDATA1 (0xA07Dh) Checksum/CRC Data Register 1 R/W (0x00)

	7	6	5	4	3	2	1	0
RD	CCDATA[15-0]							
WR	CCDATA[15-0]							

CCDATA2 (0xA07Eh) Checksum/CRC Data Register 2 R/W (0x00)

	7	6	5	4	3	2	1	0
RD	CCDATA[23-16]							
WR	CCDATA[23-16]							

CCDATA3 (0xA07Fh) Checksum/CRC Data Register 2 R/W (0x00)

	7	6	5	4	3	2	1	0
RD	CCDATA[31-24]							
WR	CCDATA[31-24]							

5.16 Break Point and Debug Controller

The CPU core also includes a Break Point Controller for software debugging purposes and handling exceptions. Program Counter break point is triggered at PC address matching, and there are seven PC matching settings available. Single Step break point triggers at interaction return from an interrupt routine.

Upon the matching of break point conditions, the Break Point Controller issues a BKP Interrupt for handling the break point. The BKP Interrupt vector is located at 0x7B. Upon entering the BKP ISR (Break Point Interrupt Service Routine), all interrupts and counters (WDT1, T0, T1, and T2) are disabled. To allow further interrupts and

continuing counting, the BKP ISR must be enabled. At exit, the BKP ISR setting must be restored to resume normal operations.

BPINTF (A0E0h) Break Point Interrupt Flag Register R/W (0x00)

	7	6	5	4	3	2	1	0
RD	STEP_IF	-	-	-	-	-	PC2IF	PC1IF
WR	STEP_IF	-	-	-	-	-	PC2IF	PC1IF

This register is for reading the Break Points interrupt flags.

- STEP_IF This bit is set when the Break Point conditions are met by a new instruction fetching from an interrupt routine. This bit must be cleared by software.
- PC2IF – PC1IF These bits are set when Break Point conditions are met by PC2 to PC1 address. These bits must be cleared by software.

BPINTE (A0E1h) Break Point Interrupt Enable Register R/W (0x00) TB Protected

	7	6	5	4	3	2	1	0
RD	STEP_IE	-	-	-	-	-	PC2IE	PC1IE
WR	STEP_IE	-	-	-	-	-	PC2IE	PC1IE

This register controls the enabling of individual Break Points interrupt.

- STEP_IE Set this bit to enable Single Step break point interrupt.
- PC2IE – PC1IE Set these bits to enable PC2 and PC1 address match break point interrupts.

BPINTC (A0E2h) Break Point Interrupt Control Register R/W (0x00)

	7	6	5	4	3	2	1	0
RD	-	-	-	-	-	-	-	-
WR	-	-	-	-	-	-	-	-

This register is reserved for other applications.

BPCTRL (A0E3h) DBG and BKP ISR Control and Status Register R/W (0xFC)

	7	6	5	4	3	2	1	0
RD	DBGINTEN	DBGWDT1EN	DBGT2EN	DBGT1EN	DBGT0EN	-	-	DBGGST
WR	DBGINTEN	DBGWDT1EN	DBGT2EN	DBGT1EN	DBGT0EN	-	-	DBGGST

When entering the DBG or BKP ISR (Interrupt Service Routine), all interrupts and timers are disabled. The enabled bits are cleared by hardware reset in this register. As the interrupts and timers are disabled, the ISR can process debugging requirement in a suspended state. If a specific timer should be kept active, it must be enabled by ISR after ISR entry. Before the exit of DBG and BKP ISR, the control bits should be enabled to allow the timers to resume operating. This register should be modified only in Debug ISR.

- DBGINTEN Set this bit to enable all interrupts (except WDT1 interrupt). This bit is cleared automatically at the entry of DBG and BKP ISR. Set this bit to allow ISR to be further interrupted by other interrupts. This is sometimes necessary if DBG or BKP ISR needs to use UART or I²C, for example.
- DBGWDT1EN Set this bit to allow WDT1 counting during the DBG and BKP ISR. This bit should always be set before exiting the ISR.
- DBGT2EN Set this bit to allow T2 counting during the DBG and BKP ISR. This bit should always be set before exiting the ISR. This bit only controls the counting but not T2 interrupt.
- DBGT1EN Set this bit to allow T1 counting during the DBG and BKP ISR. This bit should always be set before exiting the ISR. This bit only controls the counting but not T1 interrupt.
- DBGT0EN Set this bit to allow T0 counting during the DBG and BKP ISR. This bit should always be set before exiting the ISR. This bit only controls the counting but not T0 interrupt.
- DBGST This bit indicates the DBG and BKP ISR status. It is set to 1 when entering DBG and BKP ISR. It should be cleared when exiting the DBG and BKP ISR. Check this bit to allow other interrupt routine to determine whether it is a sub-service of the DBG and BKP ISR.

IS32CS8975

PC1AL (A0F0h) Program Counter Break Point 1 Low Address Register R/W (0x00)

	7	6	5	4	3	2	1	0
RD	PC1AL[7-0]							
WR	PC1AL[7-0]							

This register defines the PC low address for PC match break point 1.

PC1AH (A0F1h) Program Counter Break Point 1 High Address Register R/W (0x00)

	7	6	5	4	3	2	1	0
RD	PC1AH[7-0]							
WR	PC1AH[7-0]							

This register defines the PC high address for PC match break point 1.

PC1AT (A0F2h) Program Counter Break Point 1 Top Address Register R/W (0x00)

	7	6	5	4	3	2	1	0
RD	PC1AT[7-0]							
WR	PC1AT[7-0]							

This register defines the PC top address for PC match break point 1. PC1AT:PC1HT:PC1LT together forms a 24 bit value to compare with the value of break point 1 for Program Counter.

PC2AL (A0F4h) Program Counter Break Point 2 Low Address Register R/W (0x00)

	7	6	5	4	3	2	1	0
RD	PC2AL[7-0]							
WR	PC2AL[7-0]							

This register defines the PC low address for PC match break point 2.

PC2AH (A0F5h) Program Counter Break Point 2 High Address Register R/W (0x00)

	7	6	5	4	3	2	1	0
RD	PC2AH[7-0]							
WR	PC2AH[7-0]							

This register defines the PC high address for PC match break point 2.

PC2AT (A0F6h) Program Counter Break Point 2 Top Address Register R/W (0x00)

	7	6	5	4	3	2	1	0
RD	PC2AT[7-0]							
WR	PC2AT[7-0]							

This register defines the PC top address for PC match break point 2. PC2AT:PC2HT:PC2LT together forms a 24-bit value to compare with the value of PC break point 2 for Program Counter.

The host or program can obtain the status of the break point controller through the current break point address and next PC address register. DBPCID[23-0] contains the PC address of just executed instruction when the break point occurs. DBNXP[23-0] contains the next PC address to be executed when the break point occurs, and therefore it is usually exactly the same value of the break pointer setting.

DBPCIDL (A098h) Debug Program Counter Address Low Register RO (0x00)

	7	6	5	4	3	2	1	0
RD	DBPCID[7-0]							
WR	-							

IS32CS8975

DBPCIDH (A099h) Debug Program Counter Address High Register RO (0x00)

	7	6	5	4	3	2	1	0
RD	DBPCID[15-8]							
WR	-							

DBPCIDT (A09Ah) Debug Program Counter Address Top Register RO (0x00)

	7	6	5	4	3	2	1	0
RD	DBPCID[23-16]							
WR	-							

DBPCNXL (A09Bh) Debug Program Counter Next Address Low Register RO (0x00)

	7	6	5	4	3	2	1	0
RD	DBPCNX[7-0]							
WR	-							

DBPCNXH (A09Ch) Debug Program Counter Next Address High Register RO (0x00)

	7	6	5	4	3	2	1	0
RD	DBPCNX[15-8]							
WR	-							

DBPCNXT (A09Dh) Debug Program Counter Next Address Top Register RO (0x00)

	7	6	5	4	3	2	1	0
RD	DBPCNX[23-16]							
WR	-							

STEPCTRL (A09Eh) Single Step Control Enable Register R/W (0x00)

	7	6	5	4	3	2	1	0
RD	STEPCTRL[7-0]							
WR	STEPCTRL[7-0]							

To enable single step debugging, STEPCTRL must be written with value 0x96.

5.17 Debug I²C Port

The I2C Slave 2 (I2CS2) can be configured as the debug and ISP port. This is achieved by assigning a predefined debug ID for the I2C Slave address. When a host issues an I2C access to this special address, a DBG interrupt is generated. DBG Interrupt has the highest priority. The DBG interrupt vector is located at 0x83. DBG ISR is used to communicate with the host and is usually closely associated with BKP ISR.

SI2CDBGID (A09Fh) Slave I2C Debug ID Register R/W (0x36) TB Protected

	7	6	5	4	3	2	1	0
RD	DBGSI2C2EN	SI2CDBGID[6:0]						
WR	DBGSI2C2EN	SI2CDBGID[6:0]						

DBGSI2C2EN

DBGSI2C2EN=1 enables I2CS2 as debug port. When I2CS2 receives an access of I²C address matching SI2CDBGID[6:0], a debug interrupt is generated.

SI2CDBGID[6:0]

Slave I²C ID address for debug function.

5.18 Data SRAM ECC Handling

The data SRAM (IRAM and XRAM) is configured as 1024 x 16-bit. At default, the low byte is at even address and the high byte is at odd address. For higher system integrity, ECC can be enabled. The high byte is used for ECC code, and the low byte is for data. The ECC is based on 4-bit nibble base, and therefore it can correct 1-bit error in each nibble and detect 2-bit error in each nibble. All generation and checking are done in hardware. It is strongly recommended all SRAM data should be initialized if ECC is enabled to avoid initial ECC error. If ECC encounters either an uncorrectable error, hardware will latch the address and triggers an interrupt. Software needs to examine the severity of data corruption and determine appropriate actions. Switch between

ECC and non-ECC mode, all the data in SRAM will be corrupted and require re-initialization. It is strongly suggested keeping ECC enabled for best reliability as well as noise immunity.

DECCCFG (0xA02Dh) Data ECC Configuration Register R/W (0x80) TB Protected

	7	6	5	4	3	2	1	0
RD	DECCEN	-	DECCIEN2	DECCIEN1	-	-	DECCIF2	DECCIF1
WR	DECCEN	-	DECCIEN2	DECCIEN1	-	-	DECCIF2	DECCIF1

DECCEN Data ECC Enable
 DECCIEN2 Data ECC Uncorrectable Error Interrupt Enable
 DECCIEN1 Data ECC Correctable Error Interrupt Enable
 DECCIF2 Data ECC Uncorrectable Error Interrupt Flag
 DECCIF2 is set to 1 by hardware when there is an uncorrectable error during SRAM read. DECCIF2 is set independent of DECCIEN2. DECCIF2 needs to be cleared by software.
 DECCIF1 Data ECC Correctable Error Interrupt Flag
 DECCIF1 is set to 1 by hardware when there is a correctable error during SRAM read. DECCIF1 is set independent of DECCIEN1. DECCIF1 needs to be cleared by software.

Please note if a correctable error is encountered, the data will be automatically corrected. To prevent further corruption, software should read and rewrite the data into the SRAM when a DECCIF1 interrupt occurs.

DECCADL (0xA02Eh) Data ECC Configuration and Address Register Low RO (0x00)

	7	6	5	4	3	2	1	0
RD	DECCAD[7-0]							
WR	-							

DECCADH (0xA02Fh) Data ECC Configuration and Address Register High R/W (0x80)

	7	6	5	4	3	2	1	0
RD	DECCAD[15-8]							
WR	-							

DECCAD[15-0] records the address of ECC fault when SRAM data ECC error occurs. It is read-only and reflects the address whose data causes DECCIF to be set. If DECCIF is set and not cleared, DECCAD will not be updated if further error is detected.

5.19 Program ECC Handling

The program code stored in e-Flash has built-in ECC checking. The e-Flash is in 16-bit width, and when read by CPU program, the lower LSB 8-bit is read for instruction and the upper MSB 8-bit contains the ECC value of the LSB 8-bit. The ECC is nibble base access, flash[15-12] is [7-4] for ECC, and flash[11-8] is [3-0] for ECC. Four bits ECC for four bits data allows one-bit error correction and two bits error detection. This means 2-bit error corrects is possible for an 8-bit code stored, and this greatly increases the reliability of the overall program robustness.

During program fetch and execution, ECC is performed simultaneously by hardware. If any ECC correctable error is detected, the value fetched is corrected, and optionally a PECCIEN1 interrupt can be generated. If any ECC non-correctable error is detected, two options can be configured. That is generating a PECCIEN2 interrupt or generating a software reset. In both PECCIEN interrupts, the address of the error encountered is latched into PECCAD[15-0].

PECCCFG (0xA00Dh) Program ECC Configuration Register R/W (0x80) TB Protected

	7	6	5	4	3	2	1	0
RD	FCECCEN	-	PECCIEN2	PECCIEN1		-	PECCIF2	PECCIF1
WR	FCECCEN	-	PECCIEN2	PECCIEN1		-	PECCIF2	PECCIF1

FCECCEN Flash Controller Read ECC Control
 This bit controls the Flash Controller Read command. If FCECCEN=1, the Flash Controller reads low byte, and which contains ECC corrected data. If FCECCEN=0, the read operation returns the raw data from e-Flash. This bit is enabled by default.

PECCIEN2	Program ECC Uncorrectable Error Interrupt Enable
PECCIEN1	Program ECC Correctable Error Interrupt Enable
PECCIF2	Program ECC Uncorrectable Error Interrupt Flag PECCIF2 is set to 1 by hardware when program fetch from e-Flash encounters uncorrectable error. PECCIF2 is set independent of PECCIEN2. PECCIF2 needs to be cleared by software.
PECCIF1	Program ECC Correctable Error Interrupt Flag PECCIF1 is set to 1 by hardware when program fetch from e-Flash encounters correctable error. PECCIF1 is set independent of PECCIEN1. PECCIF1 needs to be cleared by software.

PECCADL (0xA00Eh) Program ECC Fault Address Register Low RO (0x00)

	7	6	5	4	3	2	1	0
RD	PECCAD[7-0]							
WR	-							

PECCADH (0xA00Fh) Program ECC Fault Address Register High R/W (0x80)

	7	6	5	4	3	2	1	0
RD	PECCAD[15-8]							
WR	-							

PECCAD[15-0] records the address of ECC fault when Flash ECC error occurs. It is read-only and reflects the last error address.

5.20 Memory and Logic BIST Test

BSTCMD (0xA016h) SRAM Built-In and Logic Self Test R/W (0x00) TB Protected

	7	6	5	4	3	2	1	0
RD	MODE[3-0]				BST	-	FAIL	FINISH
WR	MODE[3-0]				BSTCMD[3-0]			

MODE[3-0]	<p>BIST Mode Selection</p> <p>0000 – Normal Mode</p> <p>0001 – SRAM MBIST</p> <p>0010 – Reserved</p> <p>0011 – Reserved</p> <p>0100 – Register LBIST</p> <p>0101 – Reserved</p> <p>0110 – Reserved</p> <p>0111 – Reserved</p> <p>1000 – Normal Mode</p> <p>1001 – SRAM MBIST and monitor on pins</p> <p>1010 – Reserved</p> <p>1011 – Reserved</p> <p>1100 – Register LBIST and monitor on pins</p> <p>1101 – Reserved</p> <p>1110 – Reserved</p> <p>1111 – Reserved</p> <p>Please note MODE[3-0] is cleared only by POR and RSTN. Software can read this setting along with the Pass/Fail status to determine which BIST was performed and its result even after a software reset.</p>
BST	<p>BIST Status</p> <p>BST is set to 1 by hardware when BIST is in progress.</p>
FAIL	<p>BIST Test Fail Flag</p> <p>FAIL is set to 1 by hardware when BIST error has occurred. FAIL is cleared to 0 by hardware when a new BIST command is issued.</p>
FINISH	<p>BIST Completion Flag</p>

BSTCMD[3-0]

FINISH is set to 1 by hardware when BIST controller finishes the test. FINISH is cleared to 0 by hardware when a new BIST command is issued.

Memory BIST Command

Writing BSTCMD[3-0] with value 4b'0101 causes the BIST controller to perform BIST. Writing BSTCMD[3-0] with value 4b'1010 causes the BIST controller to perform BIST, and after BIST is completed, it automatically generates a software reset.

Writing BSTCMD[3-0] with value 4b'0000 causes FAIL and FINISH bits to be cleared to 0.

Any other value will either have no effect or abort any ongoing BIST.

After the BSTCMD is issued, CPU is paused until BIST is completed. And any BIST operations will result in the state of CPU in undefined states, and the content of the SRAM is undefined. Therefore, it is highly recommended that a software reset, or initialization should be performed after any BIST operation. Please also note MODE[3-0], FINISH, FAIL bits are not cleared by software resets.

TSTMON (0xA014h) Test Monitor Flag R/W (0x00)

	7	6	5	4	3	2	1	0
RD	TSTMON[7-0]							
WR	TSTMON[7-0]							

TSTMON register stores temporary status and is initialized by power-on reset only.

5.21 System Clock Monitoring

SYSCLK in normal mode is monitored by SOSC32KHz. If SYSCLK is not present in normal mode for four SOSC32KHz cycles, a hardware reset is triggered.

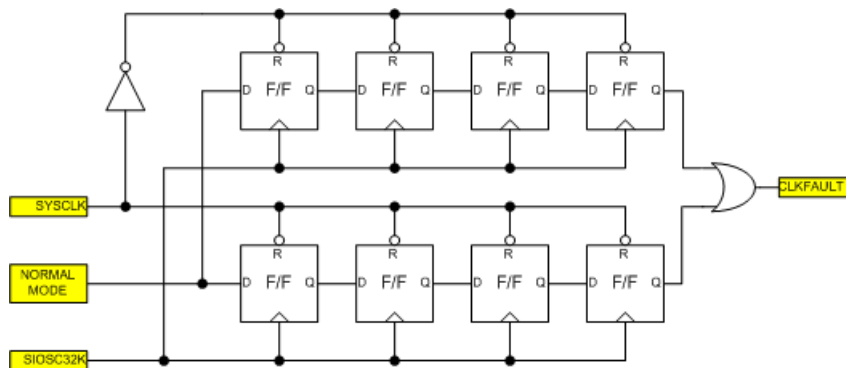

Figure 5-10 System Clock Monitor diagram

The clock monitoring is turned off by default after reset.

5.22 Reset

There are several reset sources from software and hardware. Software resets include command reset, WDT reset and ECC error reset. Hardware resets include power-on reset (low voltage detect on VDDC), LVD reset (low voltage detect on VDD), SYSCLK monitor reset, and external RSTN reset. Software reset restores some registers to default values, and hardware reset restores all registers to default values.

External RSTN reset is filtered so that low going glitches on RSTN with less than 4msec duration are ignored. All other hardware resets, once conditions are met, will be extended by 1 msec plus the external RC time as will be manifested on the RSTN pin. The reset scheme described above is shown in the following diagram.

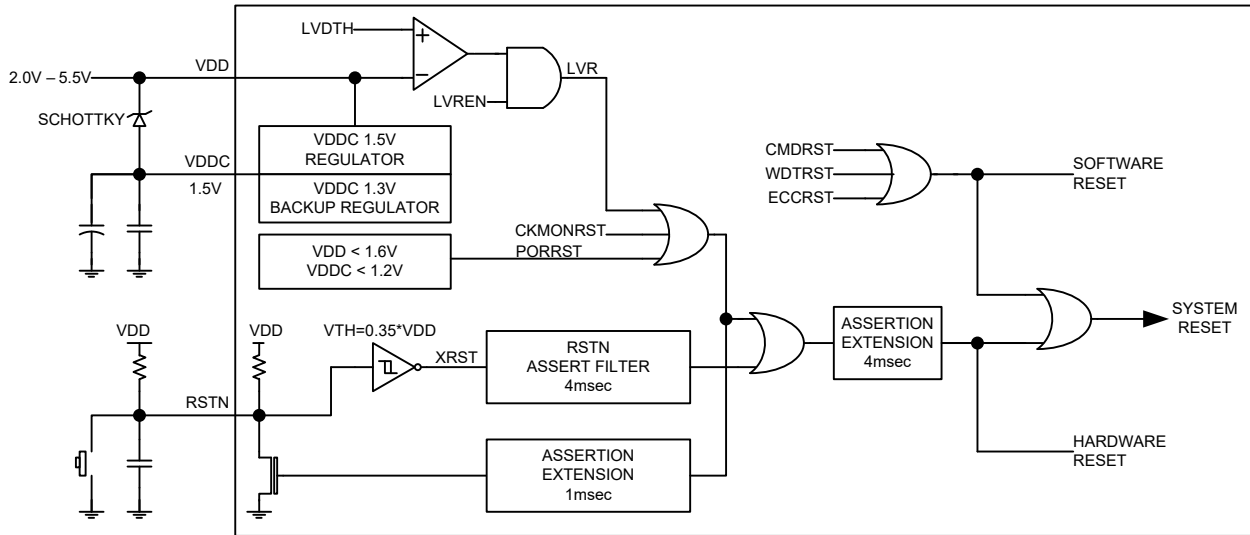

Figure 5-11 Reset block diagram

RSTCMD (0xA017h) Reset Command Register R/W (0x00) TB Protected

	7	6	5	4	3	2	1	0
RD	RSTCKM	RSTECC	-	-	CKMRF	ECCRF	WDTRF	CMDRF
WR	RSTCKM	RSTECC	-	CLRF	RSTCMD[3-0]			

- RSTCKM** Reset Enable for Clock Monitor Fault
Set RENCKM=1 to enable reset after clock fault detection. RSTCKM is cleared to 0 after any reset. Default RSTCKM value is 0.
- RSTECC** Reset Enable for Uncorrectable Code Fetch ECC Error
RSTECC=1 enables reset e-Flash code fetch ECC error. The default RSTECC value is 0.
- CKMRF** Clock Monitor Fault Reset Flag
CKMRF is set to 1 by hardware when a clock fault reset has occurred. CKMRF is not cleared by reset except power-on reset.
- ECCRF** ECC Error Reset Flag
ECCRF is set to 1 by hardware when an ECC error reset has occurred. ECCRF is cleared to 0 when writing CLRF=0. ECCRF is not cleared by reset except power-on reset.
- WDTRF** WDT Reset Flag
WDTRF is set to 1 by hardware when WTRF, WT1RF or WT2RF is set.
- CLRF** Clear Reset Flag
Writing 1 to CLRF will clear CKMRF, ECCRF, WDTRF, and CMDRF. It is self-cleared.
- RSTCMD[3-0]** Software Reset Command
Writing RSTCMD[3-0] with consecutive 4b'0101, 4b'1010 sequences will cause a software reset. Any other value will clear the sequence state. These bits are write-only and self-cleared.

IS32CS8975

6. Flash Controller

The flash controller connects the CPU to the on-chip embedded FLASH memory. The FLASH memory functions as the program storage as well as non-volatile data storage. The program access of FLASH does not require any special attention. When an ECC error during program fetch occurs, it will cause ECC to interrupt or reset.

When FLASH is used as data storage, the software issues commands to the FLASH controller through the XFR registers. Once the FLASH controller processes these commands, the CPU is held idle until the command is completed. There is a time-out mechanism to keep CPU idle to prevent CPU hang up.

From FLASH controller point of view, the embedded Flash is always in 16-bit width with no distinction between ECC and data information. For code storage through FLASH controller, ECC byte (upper MSB 8-bit) must be calculated by software. During read command, ECC error can be detected but not corrected, and the raw content is loaded into FLSHDAT[15-0]. If ECC error is detected, FAIL status is set after the read command execution.

The e-Flash contains 32 pages (also referred as Sector), and each page is 512x16. It also contains two IFB (Information Blocks) pages. In Flash operation, the erase command only operates per page base.

FLSHCMD (0xA025h) Flash Controller Command Register R/W (0x80) TB Protected

	7	6	5	4	3	2	1	0
RD	WRVfy	BUSY	FAIL	CMD4	CMD3	CMD2	CMD1	CMD0
WR	CYC[2-0]			CMD4	CMD3	CMD2	CMD1	CMD0

WRVfy

Write Result Verify. At the end of a write cycle, hardware reads back the data and compares it with which should be written to the flash. If there is a mismatch, this bit represents 0. It is set to 1 by hardware when another ISP command is executed.

BUSY

Flash command is in processing. This bit indicates that Flash Controller is executing the Flash Read, Write, or Sector Erase and other commands are not valid.

FAIL

Command Execution Result. It is set if the previous command execution fails due to any reasons. It is recommended that the program should verify the command execution result after issuing a command to the Flash controller. It won't be cleared by reading when a new command is issued. Possible reasons for FAIL include address out of range, address located at the protection region, ECC error of read access, and command timeout.

CYC[2-0]

Flash Command Timeout

CYC[2-0] defines command timeout cycle count. The cycle period is defined by ISPCLK, which is SYSCLK/256/(ISPCLKF[7-0]+1). The number of cycles is listed as follows.

CYC[2-0]			WRITE	ERASE
0	0	0	55	5435
0	0	1	60	5953
0	1	0	65	6452
0	1	1	69	6897
1	0	0	75	7408
1	0	1	80	7906
1	1	0	85	8404
1	1	1	89	8889

For normal operations, CYC[2-0] should be set to 111.

CMD4 – CMD0

Flash Command

These bits define commands for the Flash controller. The valid commands are listed in the following table. Any invalid commands do not get executed but return with a Fail bit.

CMD4	CMD3	CMD2	CMD1	CMD0	COMMAND
1	0	0	0	0	Main Memory Read
0	1	0	0	0	Main Memory Sector Erase

CMD4	CMD3	CMD2	CMD1	CMD0	COMMAND
0	0	1	0	0	Main Memory Write
0	0	0	1	0	IFB Read
0	0	0	0	1	IFB Write
0	0	0	1	1	IFB Sector Erase
1	0	0	1	0	-

IFB1 contains manufacture data and user OTP, and therefore IFB write commands are limited to IFB1 (0x0040-0x01FF) and IFB2. IFB Sector Erase is limited to IFB2. For any Read command, the high byte contains the ECC code, and the low byte contains the data. If there is an ECC error, then FAIL bit is set. To find out what ECC error occurs, software can inspect PECCIF1 and PECCIF2 bits in PECCCFG register.

To read the e-Flash raw data, the FCECCEN bit in PECCCFG register needs to be set to 0.

FLSHDATL (0xA020h) Flash Controller Data Register R/W (0x00)

	7	6	5	4	3	2	1	0
RD	Flash Read Data Register DATA[7-0]							
WR	Flash Write Data Register DATA[7-0]							

Please note DATA[7-0] in READ operation will return either ECC corrected data or e-Flash raw data depending on FCECCEN bit setting in PECCCFG register.

FLSHDATH (0xA021h) Flash Controller Data Register R/W (0x00)

	7	6	5	4	3	2	1	0
RD	Flash Read Data Register DATA[15-8]							
WR	Flash Write Data Register DATA[15-8]							

FLSHADL (0xA022h) Flash Controller Low Address Data Register R/W (0x00)

	7	6	5	4	3	2	1	0
RD	Flash Address Low Byte Register ADDR[7-0]							
WR	Flash Address Low Byte Register ADDR[7-0]							

FLSHADH (0xA023h) Flash Controller High Address Data Register R/W (0x00)

	7	6	5	4	3	2	1	0
RD	Flash Address High Byte Register ADDR[15-8]							
WR	Flash Address High Byte Register ADDR[15-8]							

FLSHECC (0xA024h) Flash ECC Accelerator Register R/W (0000 0000)

	7	6	5	4	3	2	1	0
RD	ECC[7-0]							
WR	DATA[7-0]							

FLSHECC aids the calculation of ECC value of an arbitrary 8-bit data. The data is written to FLSHECC, and its corresponding ECC value can be read out from FLSHECC.

ISPCLKF (0xA026h) Flash Command Clock Scaler R/W (0x25) TB Protected

	7	6	5	4	3	2	1	0
RD	ISPCLKF[7-0]							
WR	ISPCLKF[7-0]							

ISPCLKF[7-0] configures the clock time base for generation of Flash erase and write timing. $ISPCLK = SYSCLK * (ISPCLKF[7-0]+1)/256$. For correct timing, ISPCLK should be set approximately at 2MHz.

FLSHPRT0 (0xA030h) Flash Controller Zone Protection Register 0 R/W (0xFF) TB Protected

	7	6	5	4	3	2	1	0
RD	FLSHPRT[7-0]							
WR	FLSHPRT[7-0]							

FLSHPRT1 (0xA031h) Flash Controller Zone Protection Register 1 R/W (0xFF) TB Protected

	7	6	5	4	3	2	1	0
RD	FLSHPRT[15-8]							
WR	FLSHPRT[15-8]							

FLSHPRT2 (0xA032h) Flash Controller Zone Protection Register 2 R/W (0xFF) TB Protected

	7	6	5	4	3	2	1	0
RD	FLSHPRT[23-16]							
WR	FLSHPRT[23-16]							

FLSHPRT3 (0xA033h) Flash Controller Zone Protection Register 3 R/W (0xFF) TB Protected

	7	6	5	4	3	2	1	0
RD	FLSHPRT[31-24]							
WR	FLSHPRT[31-24]							

FLSHPRT4 (0xA034h) Flash Controller Zone Protection Register 4 R/W (0xFF) TB Protected

	7	6	5	4	3	2	1	0
RD	FLSHPRT[39-32]							
WR	FLSHPRT[39-32]							

FLSHPRT5 (0xA035h) Flash Controller Zone Protection Register 5 R/W (0xFF) TB Protected

	7	6	5	4	3	2	1	0
RD	FLSHPRT[47-40]							
WR	FLSHPRT[47-40]							

FLSHPRT6 (0xA036h) Flash Controller Zone Protection Register 6 R/W (0xFF) TB Protected

	7	6	5	4	3	2	1	0
RD	FLSHPRT[55-48]							
WR	FLSHPRT[55-48]							

FLSHPRT7 (0xA037h) Flash Controller Zone Protection Register 7 R/W (0xFF) TB Protected

	7	6	5	4	3	2	1	0
RD	FLSHPRT[63-56]							
WR	FLSHPRT[63-56]							

NOTE: Registers FLSHPRT 3~7 are not supported.

FLSHPRT partitions the total code space of 16K into 16 uniform 1K zones for protection. If the corresponding bit in the FLSHPRT is 0, the zone protection is on. All bits in FLSHPRT are set to 1 by any reset. A “1” state corresponds to an unprotected state. A bit can only be written to “0” by software and cannot be set to “1”. When a bit is “0”, the protection is on and disallows erase or modifications. For content reliability, the user’s program should turn off the corresponding access after initialization as soon as possible.

FLSHPRT[15]	Flash Zone Protect 15 This bit protects area 0x3C00 – 0x3FFF
FLSHPRT[14]	Flash Zone Protect 14 This bit protects area 0x3800 – 0x3BFF
...	...
FLSHPRT[4]	Flash Protect 4

IS32CS8975

FLSHPRT[3]	This bit protects area 0x1000 – 0x13FF Flash Protect 3
FLSHPRT[2]	This bit protects area 0x0C00 – 0x0FFF Flash Protect 2
FLSHPRT[1]	This bit protects area 0x0800 – 0x0BFF Flash Protect 1
FLSHPRT[0]	This bit protects area 0x0400 – 0x07FF Flash Protect 0
	This bit protects area 0x0000 – 0x03FF

FLSHPRTC (0xA027h) Flash Controller Code Protection Register R/W (0x00) TB Protected

	7	6	5	4	3	2	1	0
RD	-							STAT
WR	FLSHPRTC[7-0]							

This register further protects the code space (0x0000 – 0xFFFF). The protection is on after any reset. Writing “55” into this register turns off protection. However, protection is maintained until the wait time (approximately 300msec) has expired. The 300msec delay prevents any false action due to power or interface transient change. Any write value other than “55” will turn on the protection immediately. STAT bit indicates the protection status. STAT=1 indicates the protection is off, and STAT=0 indicates the protection is on.

To modify or erase the flash (not including IFB), both FLSHPRT and FLSHPRTC setting need to be satisfied at the same time. IFB1’s manufacturing data is always protected while user data can only be written “0”. IFB2 are user application data and thus not protected.

FLSHVDD (0xA015h) Flash VDD Switch Control Register R/W (0x00) TB Protected

	7	6	5	4	3	2	1	0
RD	-							SLEEPSW
WR	FLSHVDD[7-0]							

FLSHVDD is used to control the supply voltage to the e-Flash during sleep mode. Writing FLSHVDD with 0x55 will configure the SLEEPSW to 1. If SLEEPSW=1, the power supply to the e-Flash is turned off during sleep mode. Default SLEEPSW setting is 0 and the e-Flash supply is on.

IS32CS8975

7. I²C Slave Controller 2 (I2CS2)

The I²C Slave Controller 2 has dual functions – as a debug port for communication with host or as a regular I²C slave port. Both functions can coexist. I²C Slave 2 controller also supports the clock stretching functions.

The debug accessed by the host is through I²C slave address defined by SI2CSDBGID register and enabled by DBGSI2C2EN=1. When I2CS2 receives the matched address, a DBG interrupt is generated. This is described in the Debug and ISP sections. If DBGSI2C2EN=0, then I2CS2 functions as a regular I²C slave. The address of the slave is set by I2CSADR2 register. The MSB in I2CSADDR2 is the enable bit for the I²C slave controller and I2CSADR2[6-0] specifies the actual slave address.

In receive mode, the controller detects a valid matched address and issues an ADDRMI interrupt. At the same time, the data bit on SDA line is shifted into receive buffer. The RCBI interrupt is generated whenever a complete byte is received and is ready to be read from I2CSDAT. In case, the software does not respond to RCBI interrupt in time (i.e. RCBI is not cleared), and a new byte is received, the controller either forces a NACK response on I²C (if CLKSTREN bit is not set) or by pulling and holding SDA low (if CLKSTREN bit is set) to stretch the SCL low duration to force the master into a wait state. In clock stretching mode, SCL is released when the software responds to RCBI interrupt and clears RCBI flag.

In transmit mode, the controller detects a valid matched address and issues an ADDRMI interrupt. At the same time, the data preloaded in the transmit data register through I2CSDAT is transferred to the transmit shift register and is serially shifted out onto SDA line. When this occurs, the controller generates a TXBI interrupt to inform the software that a new byte can be written into I2CSDAT. When the shift register is empty and ready for the next transmit, the slave controller checks if the new byte is written to the I2CSDAT. If TXBI is not cleared, it indicates lack of new data and the slave controller holds SCL line low to stretch the current clock cycle if CLKSTREN is set. If the clock stretching is not enabled, the slave controller takes the old byte into the shift register and replies with NACK, and thus causes data corruption. On the other hand, if the master returns the NACK after the byte transfer, this indicates the end of data to the I²C slave. In this case, the I²C slave releases the data line to allow the master to generate a STOP or REPEAT START.

The I²C slave controller also implements the input noise spike filter, and this is enabled by INFILEN bit in the I2CSCON register. The filter is implemented using digital circuit. When INFILEN is set, the spikes less than 1/2 SYSCLK period on the input of SDA and SCL lines are filtered out. If INFILEN is low, no input filtering is done. The following registers are related to I²C Slave Controller. I²C slave controller uses SYSCLK to sample the SCL and SDA signals, and therefore the maximum allowable I²C bus speed is limited to SYSCLK/8 with conforming data setup and hold times. If setup and hold time cannot be guaranteed, it is recommended to limit the bus speed to 1/40 SYSCLK.

I2CSCON2 (0xDB) I2CS2 Configuration Register R/W (0x00)

	7	6	5	4	3	2	1	0
RD	-	-	-	-	-	-	-	XMT
WR	I2CSRST	EADDRMI	ESTOPI	ERPSTARTI	ETXBI	ERCBI	CLKSTREN	INFILEN

I2CSRST	I ² C Slave Reset bit Set this bit and the Slave Controller reset all internal state machine. Clear this bit for normal operations. Setting this bit clears the I2CSADR2 (I ² C slave address x).
EADDRMI	ADDRMI Interrupt Enable bit Set this bit to set ADDRMI interrupt as the I ² C slave interrupt. This interrupt is generated when I ² C slave received a matched address.
ESTOPI	STOPI Interrupt Enable bit Set this bit to set STOPI interrupt as the I ² C slave interrupt.
ERPSTARTI	RPTSTARTI Interrupt Enable Bit Set this bit to set RPTSTARTI interrupt as the I ² C slave interrupt.
ETXBI	TXBI Interrupt Enable bit. Set this bit to allow TXBI interrupt as the I ² C slave interrupt.
ERCBI	RCBI Interrupt Enable bit. Set this bit to allow RCBI interrupt as the I ² C slave interrupt.
CLKSTREN	Clock Stretching Enable bit. Set to enable the clock stretching function of the slave controller. Clock stretching is an optional feature defined in I ² C specification. If the clock stretching option is enabled (for slave I ² C), the data written into transmit buffer is shifted out only after the occurrence of clock stretching, and the data cannot be loaded to transmit shift register. The programmer needs to write the same data again to the transmit buffer.
INFILEN	Input Noise Filter Enable bit

XMT Set this bit to enable the input noise filter of SDA and SCL lines. When the filter is enabled, it filters out the spike of less than 50nsec.
 This bit is set by the controller when the I²C slave is in transmit operation and is clear when the I²C slave controller is in receive operation.

I2CSST2 (0xDC) I2CS2 Status Register R/W (0x00)

	7	6	5	4	3	2	1	0
RD	FIRSTBT	ADDRMI	STOPI	RPSTARTI	TXBI	RCBI	START	NACK
WR	DADDR	ADDRMI	STOPI	RPSTARTI	HOLDT[3]	HOLDT[2]	HOLDT[1]	HOLDT[0]

FIRSTBT This bit is set to indicate the data in the data register as the first byte received after address match. This bit is cleared after the first byte of the transaction is read. The bit is read only and generated by the slave controller.

DADDR Double Address Enable
 If DADDR=1, the LSB bit of the address register is ignored. This allows receiving two consecutive slave addresses, for example, 0x1010000 and 0x1010001.

ADDRMI Slave Address Match Interrupt Flag bit
 This bit is set when the received address matches the address defined in I2CSADR2 and an interrupt occurs if EADDMI is set. This bit must be cleared by software.

STOPI Stop Condition Interrupt Flag bit
 This bit is set when the slave controller detects a STOP condition on the SCL and SDA lines. This bit must be cleared by software.

RPTSARTI Repeat Start Condition Interrupt Flag bit
 This bit is set when the slave controller detects a REPEAT START condition on the SCL and SDA lines. This bit must be cleared by software.

TXBI Transmit Buffer Interrupt Flag
 This bit is set when the slave controller is ready to accept a new byte for transmission. This bit is cleared when new data is written into I2CSDAT register.

RCBI Receiver Buffer Interrupt Flag bit
 This bit is set when the slave controller puts new data in the I2CSDAT and is ready for software read. This bit is cleared after the software reads I2CSDAT.

START Start Condition
 This bit is set when the slave controller detects a START condition on the SCL and SDA lines. But the start of transaction can also be indicated by address match interrupt. This read-only bit is cleared when STOP condition is detected.

NACK NACK Condition
 This bit is set when the host responds with NACK in the byte transaction. This bit is only meaningful for slave transmit operation. If the master returns with NACK on the byte transaction, the slave does not upload new data into the shift register. And the slave transmits the old data again as the next transfer, and this re-transmission continues if NACK is repeated until the transmission is successful and returned with ACK. This bit is cleared when a new ACK is detected or it can be cleared by software.

HOLDT[3-0] These four bits define the hold time in SYSCLK cycles between SDA to SCL. The I²C specification requires minimum 300nsec hold time, so the “SYSCLK cycle*(HOLDT[3:0]+3) ≥ 300nsec hold time” equation must be met. For example, SYSCLK is 20MHz, then HOLD[3-0] should be set to ≥ 3.

I2CSADR2 (0xDD) I2CS2 Slave Address Register R/W (0x00)

	7	6	5	4	3	2	1	0
RD	I2CSEN	ADDR[6-0]						
WR	I2CSEN	ADDR[6-0]						

I2CSEN Set this bit to enable the I²C slave controller.

ADDR[6-0] 7-bit Slave Address
 When written, ADDR[6-0] stores the slave address of the slave.
 When read, ADDR[6-0] holds the slave address of the received slave address.
 Software can use this to determine if double address is enabled.

IS32CS8975

I2CSDAT2 (0xDE) I2CS2 Data Register R/W (0x00)

	7	6	5	4	3	2	1	0
RD	I ² C Slave Receive Data Register							
WR	I ² C Slave Transmit Data Register							

8. EUART1 Enhanced Function UART1

LIN-capable 16550-like EUART1 is an enhanced UART controller (EUART) with separate transmit and receive FIFO. Both transmit and receive FIFO are 15-bytes deep and can be parameterized for interrupt triggering. The addition of FIFO significantly reduces the CPU load to handle high-speed serial interface. Transmit FIFO and receive FIFO have respective interrupt trigger levels that can be set based on optimal CPU performance adjustment. The EUART1 also has a dedicated 16-bit Baud Rate generator and thus provides accurate baud rate under wide range of system clock frequency.

SCON1 (0xB1) EUART1 Configuration Register, R/W (0x00)

	7	6	5	4	3	2	1	0
RD	EUARTEN	SB	WLS[1]	WLS[0]	BREAK	OP	PERR	SP
WR	EUARTEN	SB	WLS[1]	WLS[0]	BREAK	OP	PE	SP

EUARTEN	Transmit and Receive Enable bit Set to enable EUART1 transmit and receive functions: Transmit messages in the TX FIFO and store received messages in the RX FIFO.
SB	Stop Bit Control Set to enable 2 Stop bits, and clear to enable 1 Stop bit.
WLS[1-0]	The number of bits of a data byte. This does not include the parity bit when it is enabled. 00 - 5 bits 01 - 6 bits 10 - 7 bits 11 - 8 bits
BREAK	Break Condition Control Bit Set to initiate a break condition on the UART interface by holding UART output at low until BREAK bit is cleared.
OP	Odd/Even Parity Control Bit
PE/PERR	Parity Enable / Parity Error status Set to enable parity and clear to disable parity checking functions. If read, PERR=1 indicates a parity error in the current data of RX FIFO.
SP	Set Parity Control Bit When SP is set, the parity bit is always 1.

SCON1X (0xB2) EUART1 Configuration Register, R/W (0x00)

	7	6	5	4	3	2	1	0
RD	RXST	BITERR	BECLR _X	BECLR _R	LBKEN	BERIE	-	TXPOL
WR	-	BITERR	BECLR _X	BECLR _R	LBKEN	BERIE	CLRFIFO	TXPOL

RXST	Receive Status RXST is controlled by hardware. RXST is set by hardware when a START bit is detected. It is cleared when STOP condition is detected.
BITERR	Bit Error Flag BITERR is set by hardware when received bit does not match with transmit bit, if BERIE=1, then this error generates an interrupt. BITERR must be cleared by software.
BECLR _X	Bit Error Force Clear Transmit Enable If BECLR _X =1, hardware will immediately disable current transmission and clear TX state machines and FIFO when BITERR is set by hardware.
BECLR _R	Bit Error Force Clear RECEIVE Enable If BECLR _X =1, hardware will immediately disable current reception and clear RX state machines and FIFO when BITERR is set by hardware.
LBKEN	Enable EUART Loopback Test, When LBKEN=1, EUART1 enters into loopback mode, with its TX output connected to RX input. In loopback mode, corresponding MFCFG bit must be cleared to prevent the TX output.
BERIE	Bit Error Interrupt Enable (1:Enable / 0:Disable)
CLRFIFO	Set to clear transmit/receive FIFO pointer and state machine. CLRFIFO bit is auto cleared by hardware

TXPOL

EUART output polarity

SFIFO1 (0xB3) EUART1 FIFO Status/Control Register R/W (0x00)

	7	6	5	4	3	2	1	0
RD	RFL[3-0]				TFL[3-0]			
WR	RFLT[3-0]				TFLT[3-0]			

RFL[3-0]

Current Receive FIFO level. These bits are read only and indicate the current receive FIFO byte count.

RFLT[3-0]

Receive FIFO trigger threshold. These bits are write only. RDA interrupt will be generated when RFL[3-0] is greater than RFLT[3-0].

RFLT[3-0]	Description
0000	RX FIFO trigger level = 0
0001	RX FIFO trigger level = 1
0010	RX FIFO trigger level = 2
0011	RX FIFO trigger level = 3
0100	RX FIFO trigger level = 4
0101	RX FIFO trigger level = 5
0110	RX FIFO trigger level = 6
0111	RX FIFO trigger level = 7
1000	RX FIFO trigger level = 8
1001	RX FIFO trigger level = 9
1010	RX FIFO trigger level = 10
1011	RX FIFO trigger level = 11
1100	RX FIFO trigger level = 12
1101	RX FIFO trigger level = 13
1110	RX FIFO trigger level = 14
1111	Reset Receive State Machine and Clear RX FIFO

TFL[3-0]

Current Transmit FIFO level. These bits are read only and indicate the current transmit FIFO byte count.

TFLT[3-0]

Transmit FIFO trigger threshold. These bits are write only. TRA interrupt will be generated when TFL[3-0] is less than TFLT[3-0].

TFLT[3-0]	Description
0000	Reset Transmit State Machine and Clear TX FIFO
0001	TX FIFO trigger level = 1
0010	TX FIFO trigger level = 2
0011	TX FIFO trigger level = 3
0100	TX FIFO trigger level = 4
0101	TX FIFO trigger level = 5
0110	TX FIFO trigger level = 6
0111	TX FIFO trigger level = 7
1000	TX FIFO trigger level = 8
1001	TX FIFO trigger level = 9
1010	TX FIFO trigger level = 10
1011	TX FIFO trigger level = 11
1100	TX FIFO trigger level = 12

TFLT[3-0]	Description
1101	TX FIFO trigger level = 13
1110	TX FIFO trigger level = 14
1111	TX FIFO trigger level = 15

SINT1 (0xB5) EUART1 Interrupt Status/Enable Register R/W (0x00)

	7	6	5	4	3	2	1	0
RD	INTEN	TRA	RDA	RFO	RFU	TFO	FERR	TI
WR	INTEN	TRAEN	RDAEN	RFOEN	RFUEN	TFOEN	FERREN	TIEN

INTEN	Interrupt Enable bit. Write only. Set to enable EUART1 interrupt. Clear to disable interrupt. The fault is 0.
TRA/TRAEN	Transmit FIFO is ready to be filled. This bit is set when transmit FIFO has been emptied below FIFO threshold. Write "1" to enable interrupt. The flag is automatically cleared when the condition is absent.
RDA/RDAEN	Receive FIFO is ready to be read. This bit is set by hardware when receive FIFO exceeds the FIFO threshold. Write "1" to enable interrupt. RDA will also be set when $RFL < RFLT$ for bus idle duration longer than $RFLT * 16 * \text{Baud Rate}$. This is to inform software that there are still remaining unread received bytes in the FIFO. The flag is cleared when $RFL < RFLT$ and writing "0" to this bit (The interrupt is disabled simultaneously.)
RFO/RFOEN	Receive FIFO Overflow Enable bit This bit is set when overflow condition of receive FIFO occurs. Write "1" to enable interrupt. The flag can be cleared by writing "0" to this bit (The interrupt is disabled simultaneously.), or by FIFO reset.
RFU/RFUEN	Receive FIFO Underflow Enable bit This bit is set when underflow condition of receive FIFO occurs. Write "1" to enable interrupt. The flag can be cleared by writing "0" to this bit (The interrupt is disabled simultaneously.), or by FIFO reset.
TFO/TFOEN	Transmit FIFO Overflow Interrupt Enable bit This bit is set when overflow condition of transmit FIFO occurs. Write "1" to enable interrupt. The flag can be cleared by writing "0" to this bit (The interrupt is disabled simultaneously.), or by FIFO reset.
FERR/FERREN	Framing Error Enable bit This bit is set when framing error occurs as the byte is received. Write "1" to enable interrupt. The flag must be cleared by writing "0" to the bit (The interrupt is disabled simultaneously.).
TI/TIEN	Transmit Message Completion Interrupt Enable bit This bit is set when all messages in the TX FIFO are transmitted and thus the TX FIFO becomes empty. Write "1" to enable interrupt. The flag must be cleared by writing "0" to this bit (The interrupt is disabled simultaneously.).

SBUF1 (0xB4) EUART1 Data Buffer Register R/W (0x00)

	7	6	5	4	3	2	1	0
RD	EUART1 Receive Data Register							
WR	EUART1 Transmit Data Register							

This register is the virtual data buffer register for both receive and transmit FIFO. When being read, it reads out the top byte of the RX FIFO; when being written, it writes into the top byte of the TX FIFO.

SBR1L (0xB6) EUART1 Baud Rate Register Low byte RO (0x00)

	7	6	5	4	3	2	1	0
RD	SBR1[7:0]							
WR	SBR1[7-0]							

IS32CS8975

SBR1H (0xB7) EUART1 Baud Rate Register High byte RO (0x00)

	7	6	5	4	3	2	1	0
RD	SBR1[15-8]							
WR	SBR1[15-8]							

SBR1[15-0]

The Baud Rate Setting of EUART. SBR1[15-0] cannot be 0.
 BUAD RATE = SYSCLK/SBR1[15-0]

9. EUART2 with LIN Controller

LIN-capable 16550-like EUART2 is an enhanced UART controller (EUART) with separate transmit and receive FIFO. Both transmit and receive FIFO are 15-bytes deep and can be parameterized for interrupt trigger. The addition of FIFO significantly reduces the CPU load to handle high-speed serial interface. Transmit FIFO and receive FIFO have respective interrupt trigger levels that can be set based on optimal CPU performance adjustment. The EUART2 also has a dedicated 16-bit Baud Rate generator and thus provides accurate baud rate under wide range of system clock frequency. The EUART2 also provides LIN extensions that incorporate message handling and baud-rate synchronization. The block diagram of EUART2 is shown in the following.

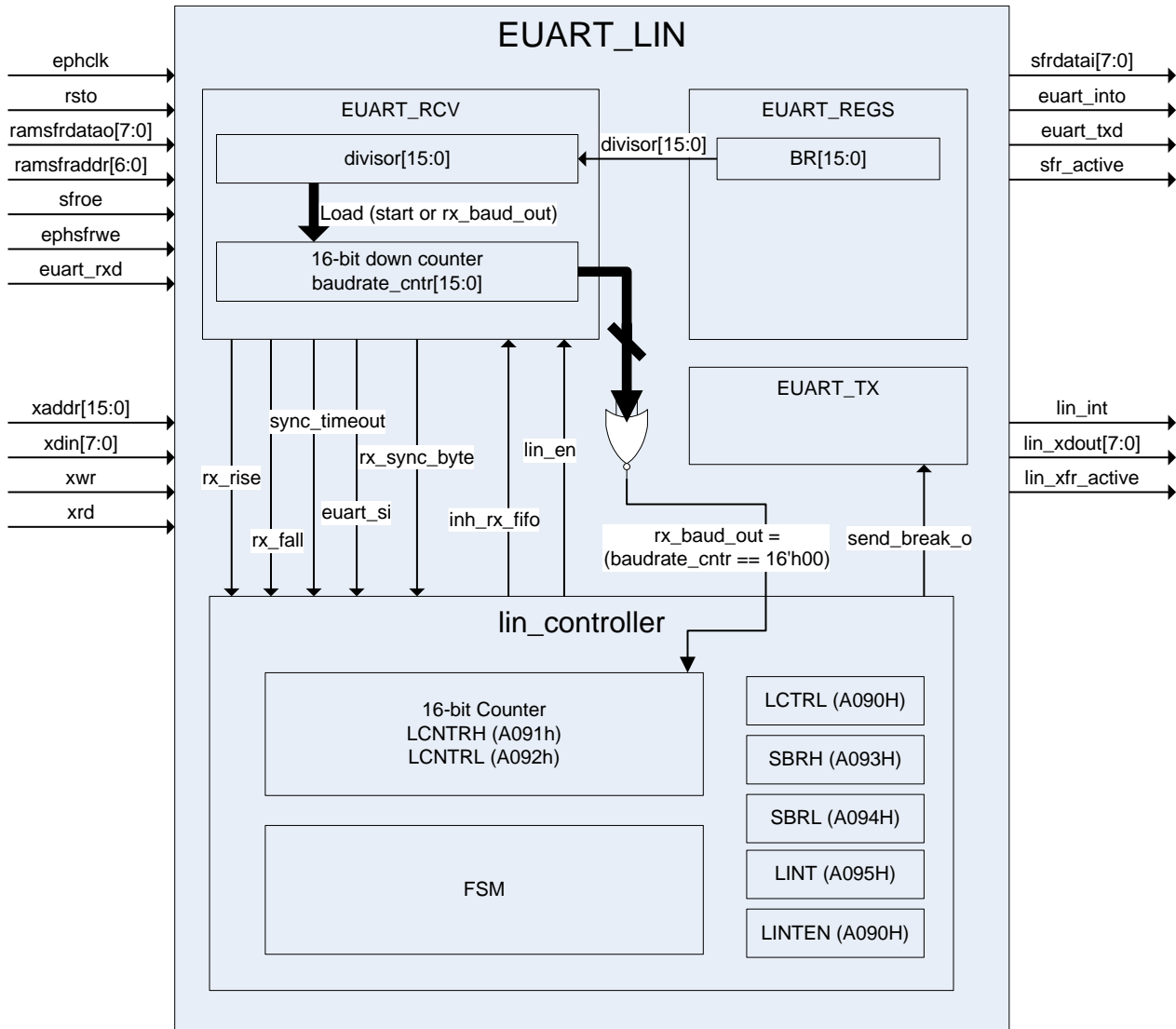

Figure 9-1 EUART2 with LIN Controller block diagram

The following registers are used for configurations of EUART2.

SCON2 (0xC2) UART2 Configuration Register R/W (0x00)

	7	6	5	4	3	2	1	0
RD	EUARTEN	SB	WLS[1]	WLS[0]	BREAK	OP	PERR	SP
WR	EUARTEN	SB	WLS[1]	WLS[0]	BREAK	OP	PE	SP

- EUARTEN Transmit and Receive Enable bit
Set to enable EUART2 transmit and receive functions: Transmit messages in the TX FIFO and store received messages in the RX FIFO.
- SB Stop Bit Control
Set to enable 2 Stop bits, and clear to enable 1 Stop bit.
- WLS[1-0] The number of bits of a data byte. This does not include the parity bit when parity is enabled.

	00 - 5 bits
	01 - 6 bits
	10 - 7 bits
	11 - 8 bits
BREAK	Break Condition Control Bit Set to initiate a break condition on the UART interface by holding UART output at low until BREAK bit is cleared.
OP	Odd/Even Parity Control Bit
PE/PERR	Parity Enable / Parity Error status Set to enable parity and clear to disable parity checking functions. If read, PERR=1 indicates a parity error in the current RX FIFO data.
SP	Parity Set Control Bit When SP is set, the parity bit is 1.

SFIFO2 (0xA5) UART2 FIFO Status/Control Register R/W (0x00)

	7	6	5	4	3	2	1	0
RD	RFL[3-0]				TFL[3-0]			
WR	RFLT[3-0]				TFLT[3-0]			

RFL[3-0] Current Receive FIFO level. These bits are read only and indicate the current receive FIFO byte count.

RFLT[3-0] Receive FIFO trigger threshold. These bits are write only. RDA interrupt will be generated when RFL[3-0] is greater than RFLT[3-0].

RFLT[3-0]	Description
0000	RX FIFO trigger level = 0
0001	RX FIFO trigger level = 1
0010	RX FIFO trigger level = 2
0011	RX FIFO trigger level = 3
0100	RX FIFO trigger level = 4
0101	RX FIFO trigger level = 5
0110	RX FIFO trigger level = 6
0111	RX FIFO trigger level = 7
1000	RX FIFO trigger level = 8
1001	RX FIFO trigger level = 9
1010	RX FIFO trigger level = 10
1011	RX FIFO trigger level = 11
1100	RX FIFO trigger level = 12
1101	RX FIFO trigger level = 13
1110	RX FIFO trigger level = 14
1111	Reset Receive State Machine and Clear RX FIFO

TFL[3-0] Current Transmit FIFO level. These bits are read only and indicate the current transmit FIFO byte count.

TFLT[3-0] Transmit FIFO trigger threshold. These bits are write only. TRA interrupt will be generated when TFL[3-0] is less than TFLT[3-0].

TFLT[3-0]	Description
0000	Reset Transmit State Machine and Clear TX FIFO
0001	TX FIFO trigger level = 1
0010	TX FIFO trigger level = 2
0011	TX FIFO trigger level = 3

TFLT[3-0]	Description
0100	TX FIFO trigger level = 4
0101	TX FIFO trigger level = 5
0110	TX FIFO trigger level = 6
0111	TX FIFO trigger level = 7
1000	TX FIFO trigger level = 8
1001	TX FIFO trigger level = 9
1010	TX FIFO trigger level = 10
1011	TX FIFO trigger level = 11
1100	TX FIFO trigger level = 12
1101	TX FIFO trigger level = 13
1110	TX FIFO trigger level = 14
1111	TX FIFO trigger level = 15

Receive and transmit FIFO can be reset by clear FIFO operation. This is done by setting BR[15-0]=0 and EUARTEN=0. This also clears RFO, RFU and TFO interrupt flags without writing the interrupt register. The LIN counter LCNTR is also cleared.

SINT2 (0xA7) UART2 Interrupt Status/Enable Register R/W (0x00)

	7	6	5	4	3	2	1	0
RD	INTEN	TRA	RDA	RFO	RFU	TFO	FERR	TI
WR	INTEN	TRAEN	RDAEN	RFOEN	RFUEN	TFOEN	FERREN	TIEN

INTEN Interrupt Enable bit. Write only.
Set to enable UART2 interrupt. Clear to disable interrupt. The fault is 0.

TRA/TRAEN Transmit FIFO is ready to be filled.
This bit is set when transmit FIFO has been emptied below FIFO threshold. Write “1” to enable interrupt. The flag is automatically cleared when the condition is absent.

RDA/RDAEN Receive FIFO is ready to be read.
This bit is set by hardware when receive FIFO exceeds the FIFO threshold. Write “1” to enable interrupt. RDA will also be set when RFL < RFLT for bus idle duration longer than RFLT * 16 * Baud Rate. This is to inform software that there are still remaining unread received bytes in the FIFO.
The flag is cleared when RFL < RFLT and writing “0” to this bit (The interrupts is disabled simultaneously.).

RFO/RFOEN Receive FIFO Overflow Enable bit
This bit is set when the overflow condition of receive FIFO occurs. Write “1” to enable interrupt. The flag can be cleared by software by writing “0” to this bit (The interrupt is disabled simultaneously.), or by FIFO reset.

RFU/RFUEN Receive FIFO Underflow Enable bit
This bit is set when underflow condition of receive FIFO occurs. Write “1” to enable interrupt. The flag can be cleared by writing “0” to this bit (The interrupt is disabled simultaneously.), or by FIFO reset.

TFO/TFOEN Transmit FIFO Overflow Interrupt Enable bit
This bit is set when overflow condition of transmit FIFO occurs. Write “1” to enable interrupt. The flag can be cleared by writing “0” to the bit (The interrupt is disabled simultaneously.), or by FIFO reset.

FERR/FERREN Framing Error Enable bit
This bit is set when framing error occurs as the byte is received. Write “1” to enable interrupt. The flag must be cleared by writing “0” to this bit (The interrupt is disabled simultaneously.).

TI/TIEN Transmit Message Completion Interrupt Enable bit
This bit is set when all messages in the TX FIFO are transmitted and thus the TX FIFO becomes empty. Write “1” to enable interrupt. The flag must be cleared by writing “0” to this bit (The interrupt is disabled simultaneously.).

IS32CS8975

SBUF2 (0xA6) UART2 Data Buffer Register R/W (0x00)

	7	6	5	4	3	2	1	0
RD	EUART2 Receive Data Register							
WR	EUART2 Transmit Data Register							

This register is the virtual data buffer register for both receive and transmit FIFO. When being read, it reads out the top byte of the RX FIFO; when being written, it writes into the top byte of the TX FIFO.

EUART2 can be configured to add LIN capability. The major enhancement of LIN includes master/slave configurations, auto baud-rate synchronization, and frame based protocol with header. Under LIN extension mode, all EUART2 registers and functions are still effective and operational. LIN is a single-wire bus and it requires external components to combine RX and TX signals externally. LIN is frame base and consists of message protocols with master/slave configurations. The following diagram shows the basic composition of a header message sent by the master. It starts with BREAK, the SYNC byte, ID bytes, DATA bytes, and CRC bytes.

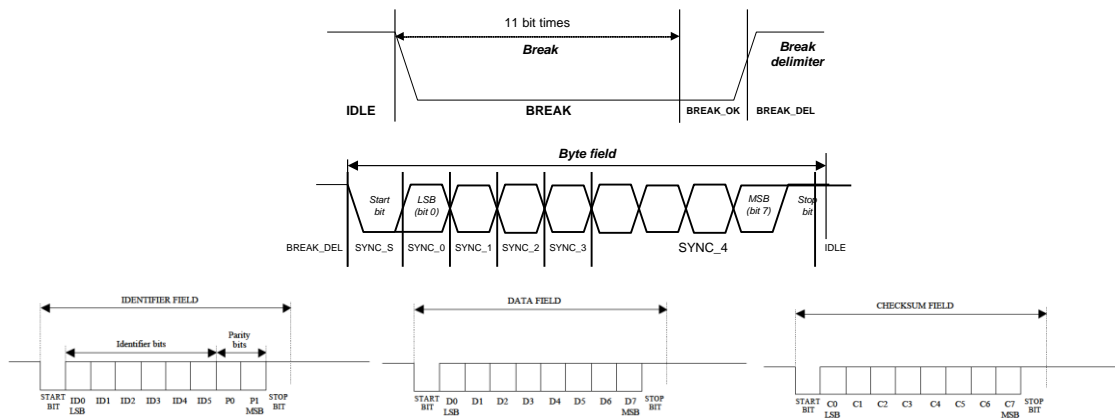

Figure 9-2 LIN frame structure

A LIN frame structure is shown and the frame time matches the number of bits sent and has a fixed timing.

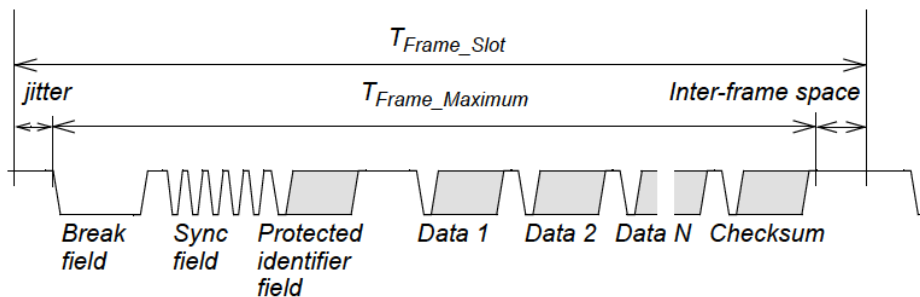

Figure 9-3 LIN frame timing

LIN bus protocol is based on frame. Each frame is partitioned into several parts as shown above. For master to initiate a frame, the software follows the following three procedures.

- Initiate a SBK command. (SW needs to check if the bus is in idle state, and there is no pending transmit data).
- Write "55" into TFIFO.
- Write "PID" into TFIFO.

Wait for SBK to complete interrupts and then write the following transmit data if applicable. (This is optional.)

The following diagram shows Finite State Machine (FSM) of the LIN extension and is followed by registers within EUART2.

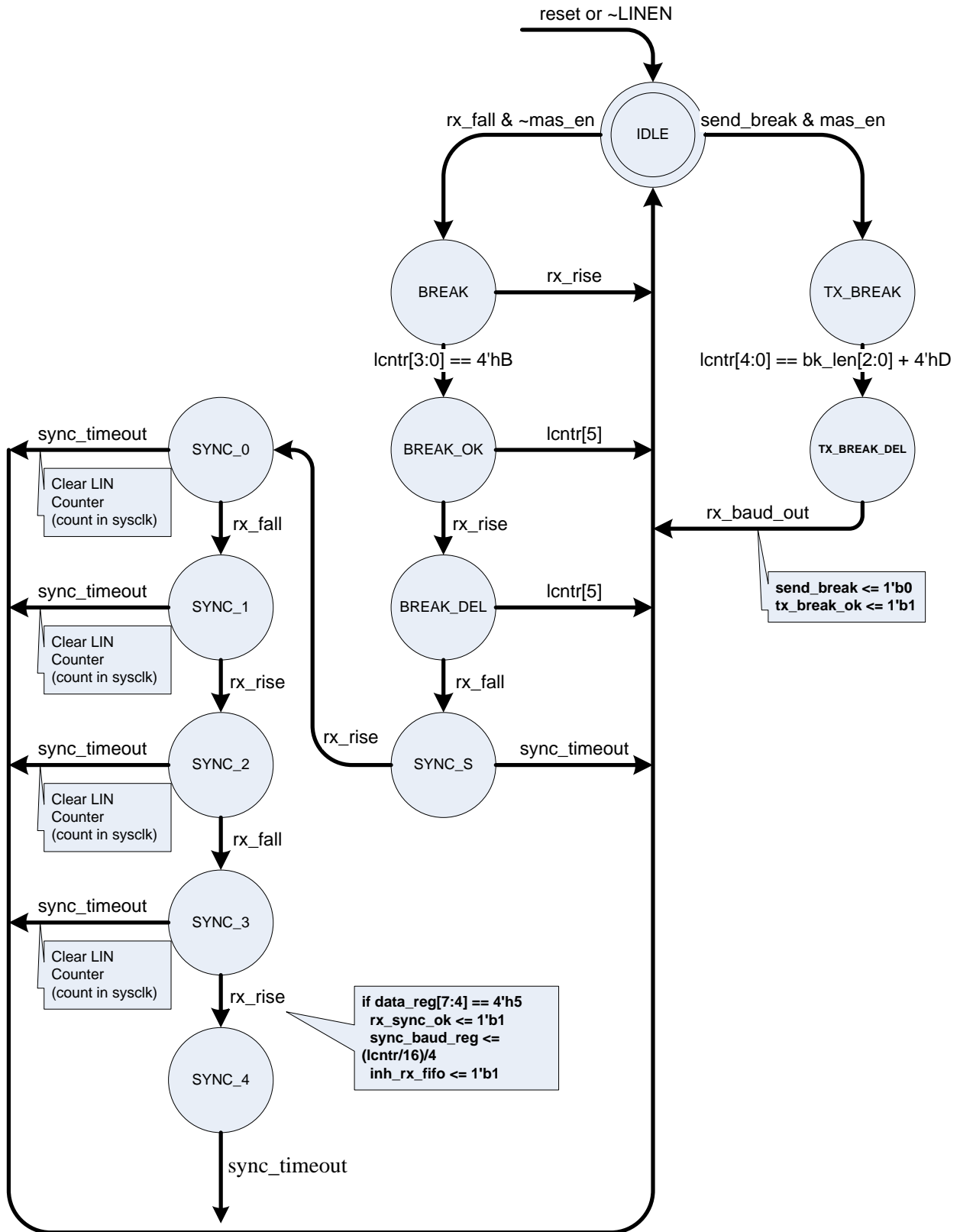

Figure 9-4 Finite State Machine of the LIN extension

LINCTRL (0xA090) LIN Status/Control Register R/W (0x00)

	7	6	5	4	3	2	1	0
RD	LINEN	MASEN	ASU	MASU	SBK	BL[2:0]		
WR	LINEN	MASEN	ASU	MASU	SBK	BL[2:0]		

LINEN	LIN Enable (1: Enable / 0: Disable) LIN header detection / transmission is functional when LINEN = 1. ※ Before enabling LIN functions, the EUART2 registers must be set correctly : 0xB0 is recommended for SCON2.
MASEN	Master Enable bit (1: Master / 0: Slave) and LIN operating mode selection. This bit is changeable only when LINEN = 0 (must clear LINEN before changing MASEN).
ASU	Auto-Sync Update Enable (1: Enable / 0: Disable). Write Only. If ASU is 1, the LIN controller will automatically overwrite BR[15-0] with SBR[15-0] and issue an ASUI interrupt when receiving a valid SYNC field. If ASU is 0, the LIN controller will only notice the synchronized baud rate in SBR[15-0] by issuing an RSI interrupt. ASU should not be set under UART mode. ASU capability is based on the message containing BREAK and SYNC field in the beginning. When ASU=1, the auto sync update is performed on every receiving frame and is updated frame by frame. When ASU is set to 1, LININTEN[SYNCCMD] should also be set to 1.
MASU	Message Auto Sync Update Enable MASU is meaningful only if ASU=0. MASU=1 will enable the auto sync update on the next received frame only. It is self-cleared when the sync update is completed. The software must set MASU again if another auto sync operation is desired. When MASU is set to 1, LININTEN[SYNCCMD] should also be set to 1.
SBK	Send Break (1: Send / 0: No send request) LINEN and MASEN should be set before setting SBK. When LINEN and MASEN are both 1, set SBK to send a bit sequence of 13+BL[2:0] consecutive dominant bits and 1 recessive bit (Break Delimiter). Once SBK is set, this bit represents the “Send Break” status and CANNOT be cleared by writing to “0”; instead, clearing LINEN cancels the “Send Break” action. In normal cases, SBK is cleared automatically when the transmission of Break Delimiter is completed.
BL[2:0]	Break Length Setting Break Length = 13 + BL[2:0]. Default BL[2:0] is 3'b000.

LINCNTRH (0xA091) LIN Timer Register High R/W (0xFF)

	7	6	5	4	3	2	1	0
RD	LCNTR[15-8]							
WR	LINTMR[15-8]							

LINCNTL (0xA092) LIN Time Register Low R/W (0xFF)

	7	6	5	4	3	2	1	0
RD	LCNTR[7-0]							
WR	LINTMR[7-0]							

LCNTR[15-0] is read only and is an internal 16-bit counter clocked by the baud rate clock. LINTMR[15-0] is write only and is the timer limit for LCNTR[15-0]. If MASEN=1 as LIN master mode, this timer is used to generate Frame time base. The internal counter LCNTR[15-0] is cleared whenever a “SEND BREAK” command is executed, and when the counter reaches LINTMR [15-0] (LCNTR[15-0] >= LINTMR[15-0]), a LCNTR0 interrupt is generated. Therefore, the software can write a Frame Time value into LINTMR and use interrupts to initiate frames. If MASEN=0 as LIN slave mode, this timer is used for determining the accumulated bus idle time. The internal counter is cleared whenever an RX transition occurs. When the internal counter reaches LINTMR[15-0], a LCNTR0 interrupt is generated. The software can use this interrupt to enter sleep mode by writing the required bus idling time into LINTMR[15-0].

LINSBRH (0xA093) EUART/LIN Baud Rate Register High byte RO (0x00)

	7	6	5	4	3	2	1	0
RD	SBR[15-8]							
WR	BR[15-8]							

LINSBRL (0xA094) EUART/LIN Baud Rate Register Low byte (0x00) RO

	7	6	5	4	3	2	1	0
RD	SBR[7:0]							
WR	BR[7:0]							

SBR[15-0] The acquired Baud Rate under LIN protocol. This is read only. SBR[15-0] is the acquired baud rate from last received valid sync byte. SBR is meaningful only in LIN-Slave mode.

BR[15-0] The Baud Rate Setting of EUART/LIN. This is write only. BR[15-0] can not be 0. BUAD RATE = SYSCLK/BR[15-0]

When a slave receives a BREAK followed by a valid SYNC field, a RSI interrupt is generated and the acquired baud rate from SYNC field is stored in SBR[15-0]. The acquired baud rate is BAUD RATE = SYSCLK/SBR[15-0]. The software can just update this acquired value into BR[15-0] to achieve synchronization with the master. If Auto-Sync Update (ASU) register bit is enabled under LIN slave mode, LIN controller will automatically perform the update of BR[15-0] with SBR[15-0] and issue another ASUI interrupt when receiving a valid SYNC field.

LININT (0xA095) LIN Interrupt Flag Register R/W (0x00)

	7	6	5	4	3	2	1	0
RD	RXST	BITERR	LSTAT	LIDLE	ASUI	SBKI	RSI	LCNTRO
WR	LBKEN	BITERR	BECLR X	BECLRR	ASUI	SBKI	RSI	LCNTRO

RXST Receive Status
RXST is set by hardware when a START bit is detected. It is cleared when STOP condition is detected.

LBKEN Enable EUART Loopback Test
When LBKEN=1, EUART2 enters into loopback mode, with its TX output connected to RX input. In loopback mode, corresponding MFCFG bit must be cleared to prevent the TX output.

LBKEN Loopback Enable

BITERR Bit Error Flag
If BERIE=1, BITERR is set by hardware when the received bit does not match transmit bit, and then this error generates an interrupt. BITERR must be cleared by software.

BECLR X Bit Error Force Clear Transmit Enable
If BECLR X=1, hardware will immediately disable current transmission and clear TX state machines and FIFO when BITERR is set by hardware.

BECLRR Bit Error Force Clear RECEIVE Enable
If BECLR X=1, hardware will immediately disable current reception and clear RX state machines and FIFO when BITERR is set by hardware.

LSTAT LIN Bus Status bit (1: Recessive / 0: Dominant). Read only.
LSTAT = 1 indicates that the LIN bus (RX pin) is in recessive state.

LIDLE LIDLE is 1 when LIN bus is idle and not transmitting/receiving LIN header or data bytes. This bit is read only. It is 1 when LINEN = 0.

ASUI Auto-Sync Updated completion Interrupt (1: Set / 0: Clear)
This flag is set when auto baud rate synchronization has been completed and BR[15-0] has been updated with SBR[15-0] by hardware. It must be cleared by writing "1" to this bit.

SBKI Send Break Completion Interrupt bit (1: Set / 0: Clear)
This flag is set when Send Break is completed. It must be cleared by writing "1" to this bit.

RSI Receive Sync Completion Interrupt bit (1: Set / 0: Clear)
This flag is set when a valid Sync byte is received following a Break. It must be cleared by writing "1" to this bit.

LCNTRO LIN Counter Overflow Interrupt bit (1: Set / 0: Clear)
This flag is set when the LIN counter reaches 0xFFFF. It must be cleared by writing "1" to this bit.

LININTEN (0xA096) LIN Interrupt Enable Register R/W (0x00)

	7	6	5	4	3	2	1	0
RD	LINTEN	BERIE	SYNCMD	SYNCVD	ASUIE	SBKIE	RSIE	LCNTRIE
WR	LINTEN	BERIE	SYNCMD	EUARTOPL	ASUIE	SBKIE	RSIE	LCNTRIE

LINTEN	LIN Interrupt Enable (1: Enable / 0: Disable) Set to enable all LIN interrupts. LINT flags should be checked before setting or modifying.
BERIE	Bit Error Interrupt Enable (1:Enable/ 0:Disable)
SYNCMD	Synchronization Mode Selection SYNCMD=1 will automatically re-synchronize with newly received message frame and update the baud rate register with newly acquired baud rate. SYNCMD should be set to 1 when either ASU or MASU is 1.
SYNCVD	Synchronization Valid Status SYNCVD is updated by the hardware when SYNCMD=1. SYNCVD is set to 1 if the auto synchronization is successful.
EUARTOPL	EUART/LIN output polarity EUARTOPL=1 will reverse the transmit output polarity.
ASUIE	Auto-Sync Update Interrupt Enable (1: Enable / 0: Disable)
SBKIE	Send Break Completion Interrupt Enable (1: Enable / 0: Disable)
RSIE	Receive Sync Completion Interrupt Enable (1: Enable / 0: Disable)
LCNTRIE	LIN Counter Overflow Interrupt Enable (1: Enable / 0: Disable)

LINTCON (0xA0B0h) LIN Time Out configuration R/W (0x00)

	7	6	5	4	3	2	1	0
RD	RXDTO[0]	LINRXFEN	RXTOWKE	TXTOWKE	RXDD_F	TXDD_F	RXDDEN	TXDDEN
WR	RXDTO[0]	LINRXFEN	RXTOWKE	TXTOWKE	RXDD_F	TXDD_F	RXDDEN	TXDDEN

RXDTO[0]	RXD Dominant Time Out Timer [0] This is combined with RXDTH and RXDTOL to form RXDTH[16-0]
LINRXFEN	LIN Break State Exit when RXD dominant fault occurs. LINRXFEN=1 configures the automatic BREAK state exit under RXD dominant fault conditions. LINRXFEN=0 disables this automatic exit (Not affect other break exit conditions.). Software must take care of the LIN state machine.
RXDDEN	RXD Dominant Fault Interrupt Enable
RXDD_F	RXD Dominant Fault Interrupt Flag RXDD_F is set to 1 by hardware and must be cleared by software.
TXDDEN	TXD Dominant Fault Interrupt Enable
TXDD_F	TXD Dominant Fault Interrupt Flag TXDD_F is set to 1 by hardware and must be cleared by software.
TXTOWKE	TXD Dominant Timeout Wakeup Enable
RXTOWKE	RXD Dominant Timeout Wakeup Enable

TXDTOL (0xA0B1h) LIN TXD Dominant Time Out LOW Registers R/W (0x00)

	7	6	5	4	3	2	1	0
RD	TXDTH[7:0]							
WR	TXDTH[7:0]							

TXDTH (0xA0B2h) LIN TXD Dominant Time Out HIGH Registers R/W (0x00)

	7	6	5	4	3	2	1	0
RD	TXDTH[15:8]							
WR	TXDTH[15:8]							

TXDTH TXD Dominant Time Out (TXDTH +1) * IOSCLK

IS32CS8975

RXDTOL (0xA0B3h) LIN RXD Dominant Time Out LOW Registers R/W (0x00)

	7	6	5	4	3	2	1	0
RD	RXDTO[8-1]							
WR	RXDTO[8:1]							

RXDTOH (0xA0B4h) LIN RXD Dominant Time Out HIGH Registers R/W (0x00)

	7	6	5	4	3	2	1	0
RD	RXDTO[16-9]							
WR	RXDTO[16-9]							

RXDTO RXD Dominant Time Out (RXDTO[16-0] +1) * IOSCLK

BSDCLRL (0xA0B5h) Bus Stuck Dominant Clear Width Low Registers R/W (0x00)

	7	6	5	4	3	2	1	0
RD	BSDCLR[7-0]							
WR	BSDCLR[7-0]							

BSDCLRH (0xA0B6h) Bus Stuck Dominant Clear Width High Registers R/W (0x00)

	7	6	5	4	3	2	1	0
RD	BSDCLR[15-8]							
WR	BSDCLR[15-8]							

BSDCLR Bus Stuck Dominant Clear Time (BSDCLR[15-0] +1) * SOSC32KHz

BSDACT (0xA0B8h) Bus Stuck Dominant Active Width Registers R/W (0x00)

	7	6	5	4	3	2	1	0
RD	BSDACT[7-0]							
WR	BSDACT[7:0]							

BSDACT Bus Stuck Dominant Active Time (BSDACT[7-0] +1) * SOSC32KHz

BSDWKC (0xA0B7h) Bus Stuck Dominant Fault Wakeup configuration R/W (0x00)

	7	6	5	4	3	2	1	0
RD	BSDWF	BFWF	BSDWEN	BFWEN	WKFLT[3-0]			
WR	BSDWF	BFWF	BSDWEN	BFWEN	WKFLT[3-0]			

WKFLT[3-0] LIN Wakeup time (WKFLT[3-0]+1) * SOSC32KHz
 BFWEN LIN Wakeup/Interrupt Enable
 BFWF LIN Wakeup Interrupt Flag
 BFWF is set to 1 by hardware and must be cleared by software
 BSDWEN LIN Bus Stuck Wakeup Interrupt Enable
 BSDWF LIN Bus Stuck Wakeup Interrupt Flag

IS32CS8975

10. Serial Peripheral Interface (SPI)

The Serial Peripheral Interface (SPI) is an enhanced synchronous serial hardware, which is compatible with Motorola's SPI specifications. The SPI Controller includes 4-bytes FIFO for both transmit and receive. SPI Interface uses Master-Out-Slave-In (MOSI), Master-In-Slave-Out (MISO), Serial Clock (SCK) and Slave Select (SSN) for interface. SSN is low active and only meaningful in slave mode.

We have application notes SPI-CS89xx_AP note.pdf to describe how to use the SPI by polling or by interrupt handling.

SPICR (0xA1) SPI Configuration Register R/W (0b001000xx)

	7	6	5	4	3	2	1	0
RD	SPIE	SPEN	MSTR	CPOL	CPHA	SCKE	SICKFLT	SSNFLT
WR	SPIE	SPEN	MSTR	CPOL	CPHA	SCKE	SICKFLT	SSNFLT

SPIE SPI interface Interrupt Enable bit
SPEN SPI interface Enable bit
MSTR SPI Master/Slave Switch. Set as a master; clear as a slave.
CPOL SPI interface Polarity bit: Set to configure the SCK to stay HIGH while the SPI interface is idling and clear to keep it LOW.
CPHA Clock Phase Control bit: If CPOL=0, set to shift output data at rising edge of SCK, and clear to shift output data at falling edge of SCK. If CPOL=1, set to shift output data at falling edge of SCK and clear to shift output data at rising edge of SCK.
SCKE Clock Edge Selection bit for Master Mode
 SCKE = 0 SDI and SDO use opposite SCK edges.
 SCKE = 1 SDI and SDO use the same SCK edges.
 CPOL, CPHA and SCKE together define the edge relationship between SCK edges used for sampling SDO/SDI as shown in the following table. Here R means rising edge and F means falling edge.

SCKE	CPOL	CPHA	MASTER		SLAVE	
			SDI	SDO	SDI	SDO
0	0	0	R	F	R	F
0	0	1	F	R	F	R
0	1	0	F	R	F	R
0	1	1	R	F	R	F
1	0	0	F	F	R	F
1	0	1	R	R	F	R
1	1	0	R	R	F	R
1	1	1	F	F	R	F

SSNFLT Enable noise filter function on signal SSN
SICKFLT Enable noise filter function on signals SDI and SCK

SPIMR (0xA2) SPI Mode Control Register R/W (0x00)

	7	6	5	4	3	2	1	0
RD	ICNT1	ICNT0	FCLR	-	SPR[2]	SPR[1]	SPR[0]	DIR
WR	ICNT1	ICNT0	FCLR	-	SPR[2]	SPR[1]	SPR[0]	DIR

ICNT1, ICNT0 FIFO Byte Count Threshold
 This sets the FIFO threshold for generating SPI interrupts.
 00 –the interrupt is generated after 1 byte is sent or received;
 01 –the interrupt is generated after 2 bytes are sent or received;
 10 –the interrupt is generated after 3 bytes are sent or received;
 11 –the interrupt is generated after 4 bytes are sent or received.
FCLR FIFO Clear/Reset
 Set to clear and reset transmit and receive FIFO
SPR[2-0] SPI Clock Rate Setting. This is used to control the SCK clock rate of SPI interface.

- 000 – SCK = SYSCLK/4;
- 001 – SCK = SYSCLK/6;
- 010 – SCK = SYSCLK/8;
- 011 – SCK = SYSCLK/16;
- 100 – SCK = SYSCLK/32;
- 101 – SCK = SYSCLK/64;
- 110 – SCK = SYSCLK/128;
- 111 – SCK = SYSCLK/256.

DIR Transfer Format
 DIR=1 uses MSB-first format.
 DIR=0 uses LSB-first format.

SPIST (0xA3) SPI Status Register R/W (0x00)

	7	6	5	4	3	2	1	0
RD	SSPIF	ROVR	TOVR	TUDR	RFULL	REMP	TFULL	TEMPT
WR	SSPIF	ROVR	TOVR	TUDR	-	-	-	-

SSPIF SPI Interrupt Flag bit. Set by hardware to indicate the completion of data transfer. Clear by assigning this bit to 0 or disabling SPI.

ROVR Receive FIFO-overflow Error Flag bit. When Receiver FIFO Full Status occurs and SPI receives new data, ROVR is set and generates an interrupt. Clear by assigning this bit to 0 or disabling SPI.

TOVR Transmit FIFO-overflow Error Flag bit. When Transfers FIFO Full Status occurs and new data is written, TOVR is set and generates an interrupt. Clear by assigning this bit to 0 or disabling SPI.

TUDR Transmit Under-run Error Flag bit. When Transfers FIFO Empty Status and new data transmission occur, TUDR is set and generates an interrupt. Clear by written 0 to this bit or disable SPI.

RFULL Receive FIFO Full Status bit. Set when receiver FIFO is full. Read only.

REMP Receive FIFO Empty Status bit. Set when receiver FIFO is empty. Read only.

TFULL Transmitter FIFO Full Status bit. Set when transfer FIFO is full. Read only.

TEMPT Transmitter FIFO Empty Status bit. Set when transfer FIFO is empty. Read only.

SPIDATA (0xA4) SPI Data Register R/W (0xXX)

	7	6	5	4	3	2	1	0
RD	SPI Receive Data Register							
WR	SPI Transmit Data Register							

10.1 SPI Master Timing Illustration

10.1.1 CPOL=0 CPHA=0

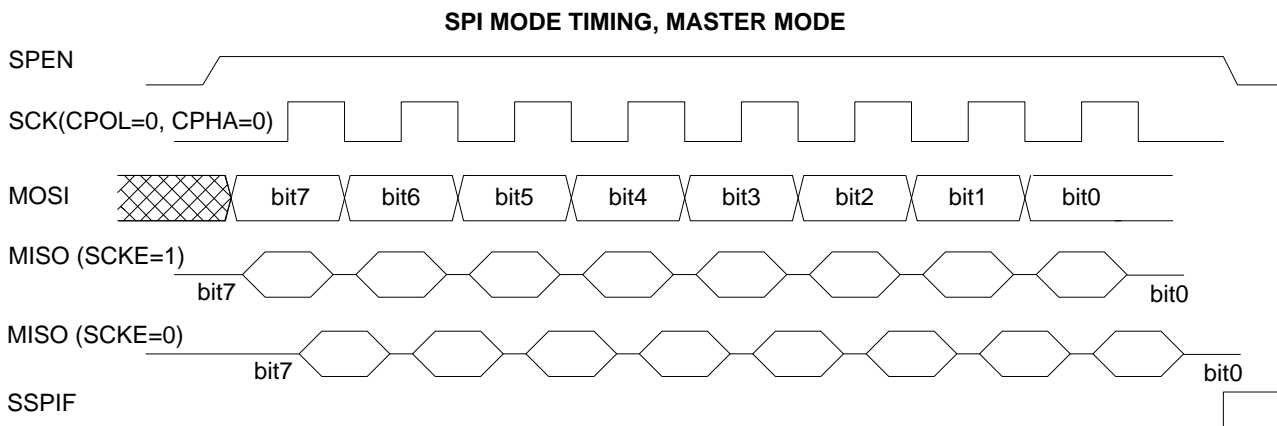

Figure 10-1 SPI Master Timing with CPOL=0, CPHA=0

10.1.2 CPOL=0 CPHA=1

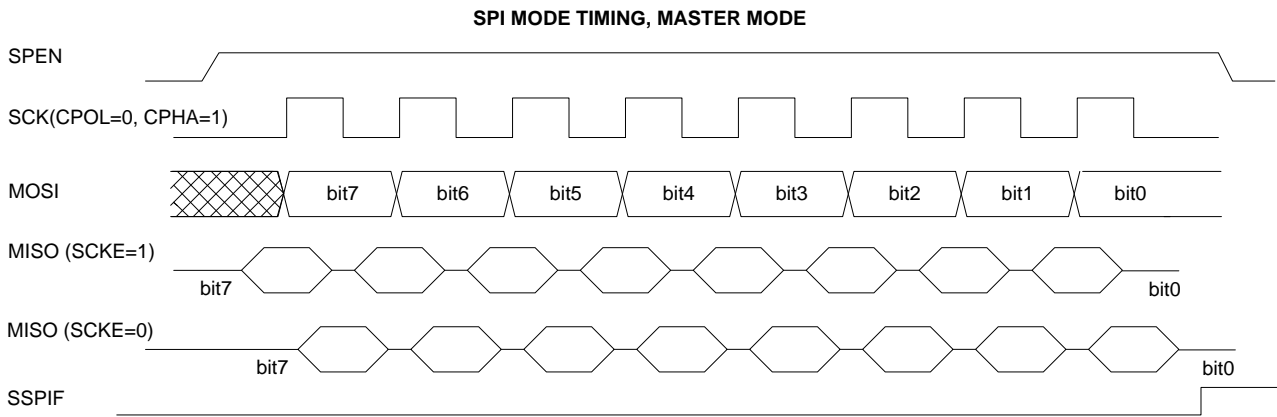

Figure 10-2 SPI Master Timing with CPOL=0, CPHA=1

10.1.3 CPOL=1 CPHA=0

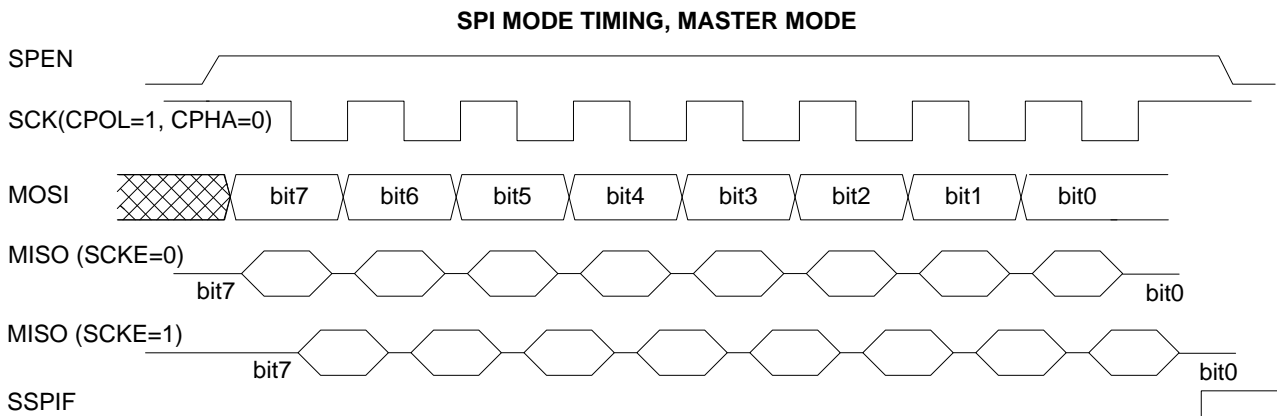

Figure 10-3 SPI Master Timing with CPOL=1, CPHA=0

10.1.4 CPOL=1 CPHA=1

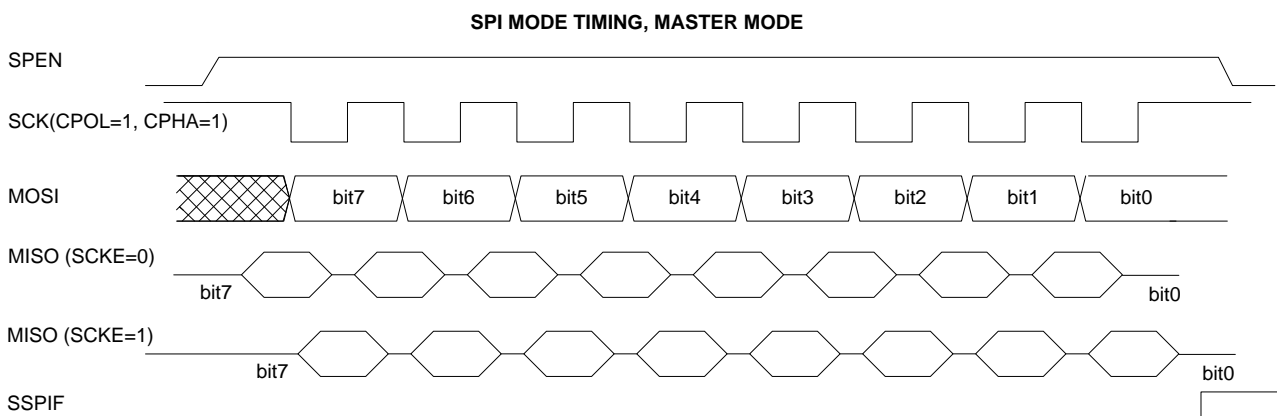

Figure 10-4 SPI Master Timing with CPOL=1. CPHA=1

10.2 SPI Slave Timing Illustration

10.2.1 CPOL=0 CPHA=0

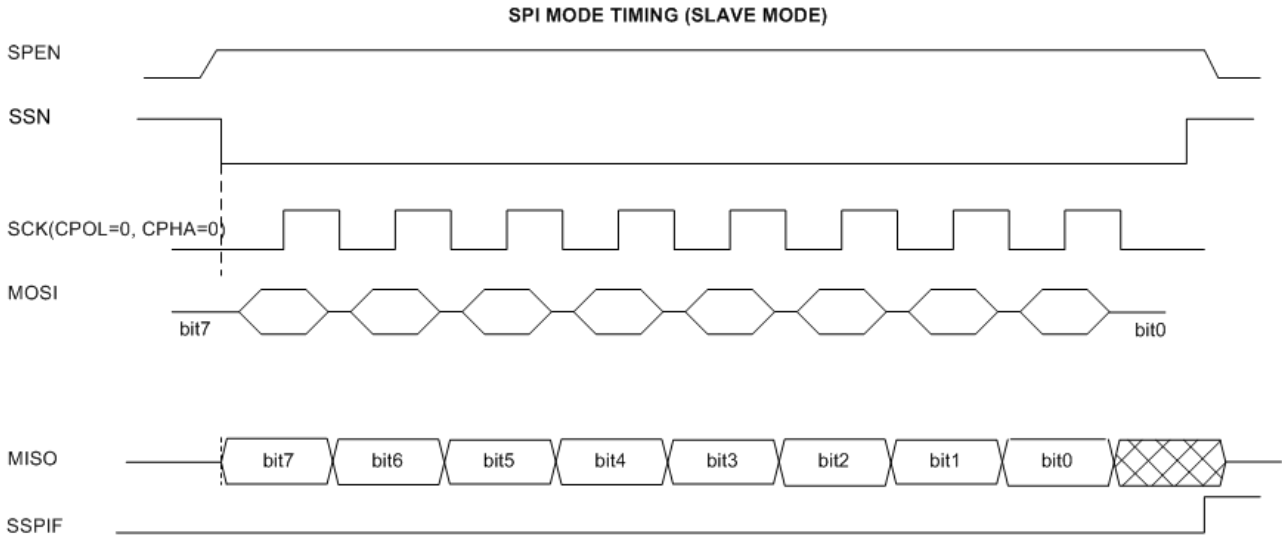

Figure 10-5 SPI Slave Timing with CPOL=0, CPHA=0

10.2.2 CPOL=0 CPHA=1

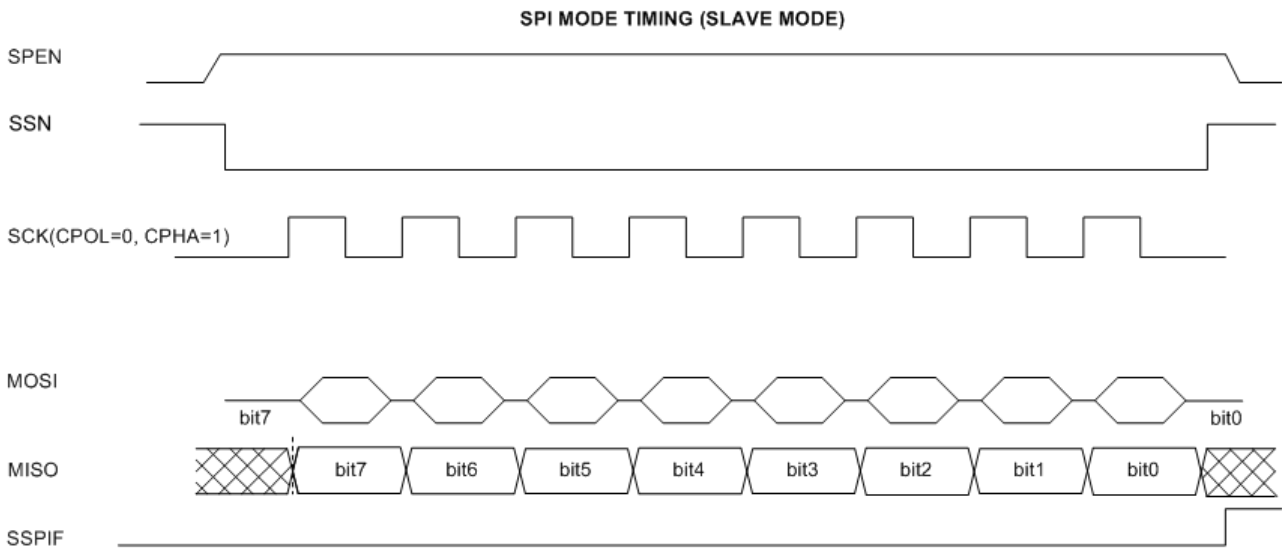

Figure 10-6 SPI Slave Timing with CPOL=0, CPHA=1

10.2.3 CPOL=1 CPHA=0

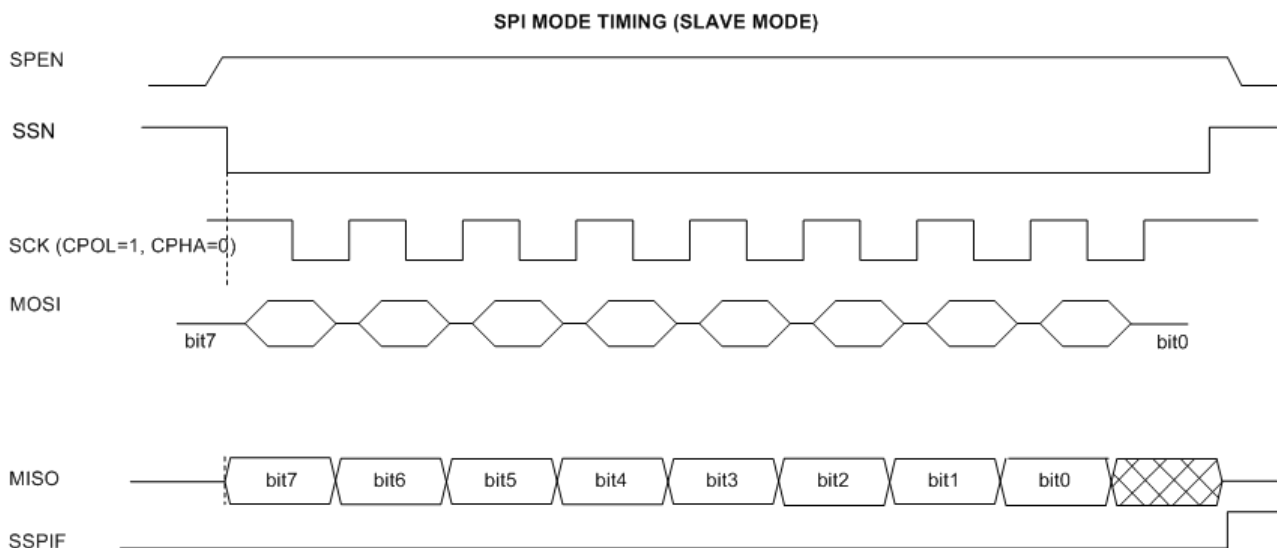

Figure 10-7 SPI Slave Timing with CPOL=1. CPHA=0

10.2.4 CPOL=1 CPHA=1

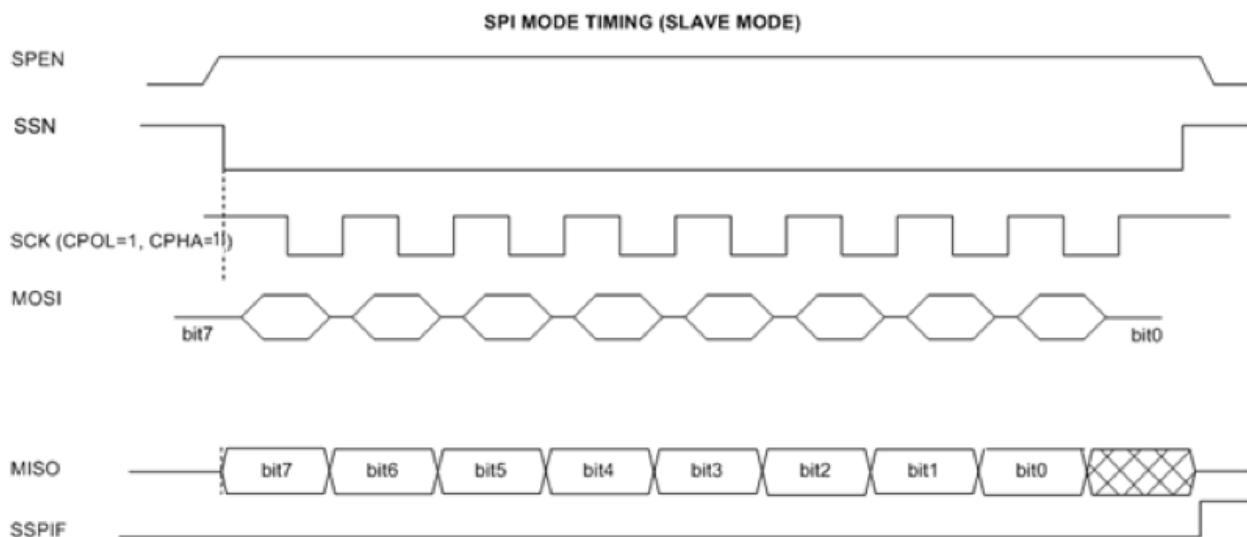

Figure 10-8 SPI Slave Timing with CPOK=1, CPHA=1

IS32CS8975

11. Timer with Compare/Capture and Quadrature Encoder

The Timer/Capture unit is based on a 16-bit counter with pre-scalable SYSCLK as counting clock. The count starts from 0 and reloads when reaching TC (terminal count). TC is reached when the count equals period value. Along with the counting, the count value is compared with COMP and when it matches, a CC condition is met. Note that both PERIOD and COMP register are double buffered, and therefore any new value is updated after the current period ends. TC and CC can be used for triggering interrupt and routed to GPIO. The output pulse width of TC and CC is programmable. For CC, it can also be configured as a PWM output. There are two data registers to capture events. The capture event can be from external signals from GPIO (XCAPT) with edge selection option, from QE block, or triggered by software. The software can also select if to reset the counter or not, and this option gives a simpler calculation of consecutive capture events without any offset. The following block diagram shows the TCC implementations.

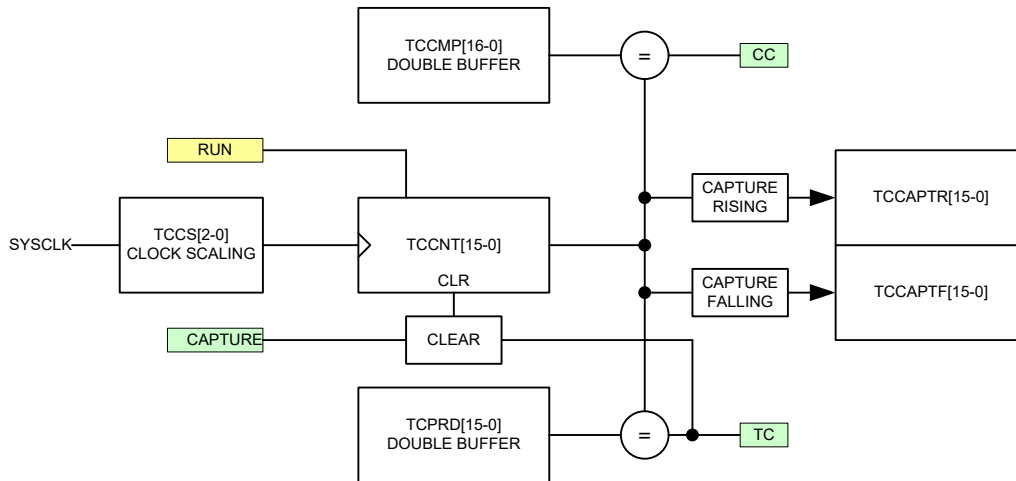

Figure 11-1 TCC implementations diagram

TCCFG1 (0xA050h) TCC Configuration Register 1 R/W (0x00)

	7	6	5	4	3	2	1	0
RD	TCEN	TCCS[2-0]			CCSEL[1-0]		TCSEL	RUNST
WR	TCEN	TCCS[2-0]			CCSEL[1-0]		TCSEL	RUN

TCEN

TC Enable

TC = 0 disables TC. In disabled state, TCCNT, and TCCPTR/TCCPTF are cleared to 0. TC and CC are also set low.

TC = 1 enable TC. RUN bit also needs to set to 1 to start the counter, otherwise if RUN=0 then counter is in pause mode.

TCCS[2-0]

TC Clock Scaling

000 SYSCLK
 001 SYSCLK/2
 010 SYSCLK/4
 011 SYSCLK/8
 100 SYSCLK/16
 101 SYSCLK/32
 110 SYSCLK/64
 111 SYSCLK/128

CCSEL[1-0]

CC Output Pulse Select

00 PW = 16 TCCLK

01 PW = 64 TCCLK

10 PWM Waveform (CC = low when TCCNT < CMP, CC = high when TCCNT >= CMP).

11 PWM Toggle waveform (CC toggles when TCCNT = CMP).

TCSEL

TC Output Pulse Select

0 PW = 16 TCCLK

1 PW = 64 TCCLK

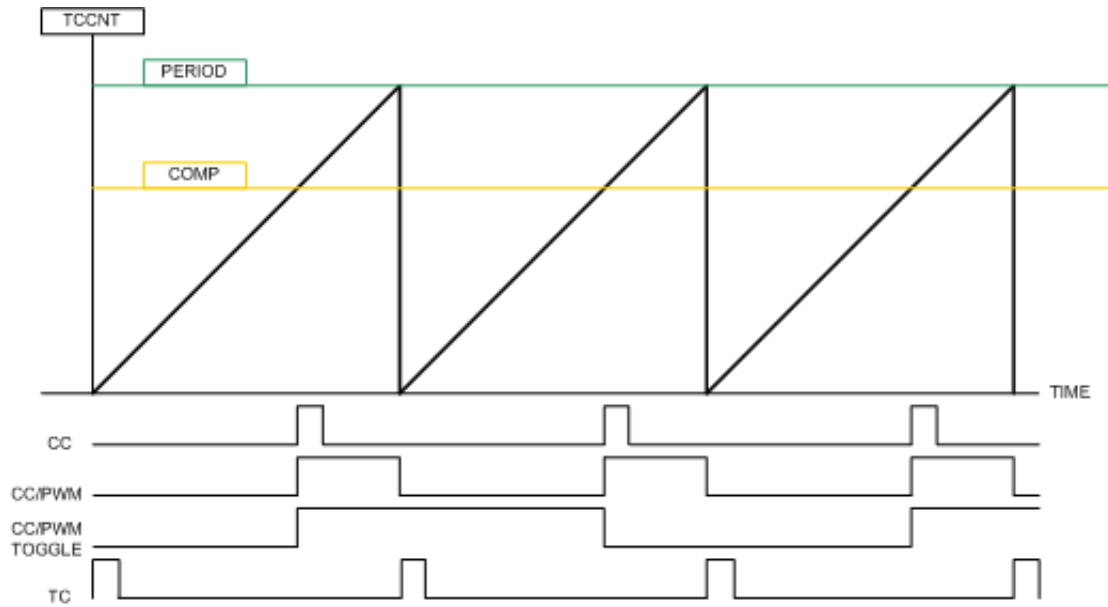

Figure 11-2 TCC timing diagram

- RUNST** Run Status
Set by hardware to indicate running TC counter. RUNST=1 indicates still running.
- RUN** Run or Pause TC Counter
Writing "0" to RUN will pause the TC counting.
Writing "1" to RUN will resume the TC counting.

TCCFG2 (0xA051h) TC Configuration Register 2 R/W (0x00)

	7	6	5	4	3	2	1	0
RD	-	IDXST	PHAST	PHBST	TCPOL	CCPOL	TCF	CCF
WR	RSTTC	-	-	-	TCPOL	CCPOL	TCF	CCF

- RSTTC** Reset TC
Writing RSTTC "1" will reset the TC counter and capture registers. Once counter is cleared, TC counter is put in STOP mode. To resume counting, RUN bit must be set by software.
- IDXST** Index Input real-time status
- PHAST** PHA input real-time status
- PHBST** PHB input real-time status
- TCPOL** TC output polarity
- CCPOL** CC output polarity
- TCF** Terminal Count Interrupt Flag
TCF is set to "1" by hardware when terminal count occurs. TCF must be cleared by writing "0".
- CCF** Compare Match Interrupt Flag
CCF is set to "1" by hardware when compare match occurs. CCF must be cleared by writing "0".

TCCFG3 (0xA052h) TC Configuration Register 3 R/W (0x00)

	7	6	5	4	3	2	1	0
RD	IENTC	IENCC	QECEN	CPTCLR	XCREN	XCFEN	-	-
WR	IENTC	IENCC	QECEN	CPTCLR	XCREN	XCFEN	SWCPTR	SWCPTF

- IENTC** TC Interrupt Enable
- IENCC** CC Interrupt Enable
- QECEN** QE Capture Enable
QECEN=1 uses QE output event as capture event.
- CPTCLR** Enable Clear Counter after Capture

	If CPTCLR=1, the TCCNT is cleared to 0 after each capture event. This allows continuous capture value with identical initial value.
	If CPTCLR=0, the capture event does not affect the TCCNT counting.
XCREN	External Rising Edge Capture Enable XCREN=1 uses external input rising edge as capture event.
XCFEN	External Falling Edge Capture Enable XCFEN=1 uses external input falling edge as capture event.
SWCPTR	Software Capture R Writing "1" to SWCPTR will generate a capture event and capture the count value into TCCPTR register. This bit is cleared by hardware.
SWCPTF	Software Capture F Writing "1" to SWCPTF will generate a capture event and capture the count value into TCCPTF register. This bit is cleared by hardware.

All capture sources are not mutually exclusive, i.e., allow several capture sources to coexist.

TCPRDL (0xA054h) TC Period Register Low Double Buffer R/W (0x00)

	7	6	5	4	3	2	1	0
RD	TCCNT[7-0]							
WR	TCPRD[7-0]							

TCPRDH (0xA055h) TC Period Register High Double Buffer R/W (0x00)

	7	6	5	4	3	2	1	0
RD	TCCNT[15-8]							
WR	TCPRD[15-8]							

Note: Writing of PERIOD register must be done high byte first, and then low byte. The writing takes effect at low byte writing. When reading the TCPRD register, it returns the current count value TCCNT[15-0].

TCCMPL (0xA056h) TC Compare Register Low Double Buffer R/W (0x00)

	7	6	5	4	3	2	1	0
RD	TCCMP[7-0]							
WR	TCCMP[7-0]							

TCCMPH (0xA057h) TC Compare Register High Double Buffer R/W (0x00)

	7	6	5	4	3	2	1	0
RD	TCCMP[15-8]							
WR	TCCMP[15-8]							

Note: Writing of COMPARE register must be done high byte first, and then low byte. The writing takes effect at low byte writing.

TCCPTRL (0xA060h) TC Capture Register R Low R/W (0x00)

	7	6	5	4	3	2	1	0
RD	TCCPTR[7-0]							
WR	-							

TCCPTRH (0xA061h) TC Capture Register R High R/W (0x00)

	7	6	5	4	3	2	1	0
RD	TCCPTR[15-8]							
WR	-							

IS32CS8975

TCCPTFL (0xA062h) TC Capture Register F Low R/W (0x00)

	7	6	5	4	3	2	1	0
RD	TCCPTF[7-0]							
WR	-							

TCCPTFH (0xA063h) TC Capture Register F High R/W (0x00)

	7	6	5	4	3	2	1	0
RD	TCCPTF[15-8]							
WR	-							

The quadrature encoder is clocked by a scaled SYSCLK and has three external inputs through GPIO multi-functions. Three inputs include two signals of 90 degrees phase difference, PHA and PHB, and an index indicating the terminal of the encoder. QE can function as an independent function block and can be configured to couple with TCC and use TCC to calculate the speed information of the encoder. Using TCC to capture TCC count value using the Index input of QE or terminal count of QE, the speed of QE input can be calculated. The QE unit implementation is shown in the following block diagram.

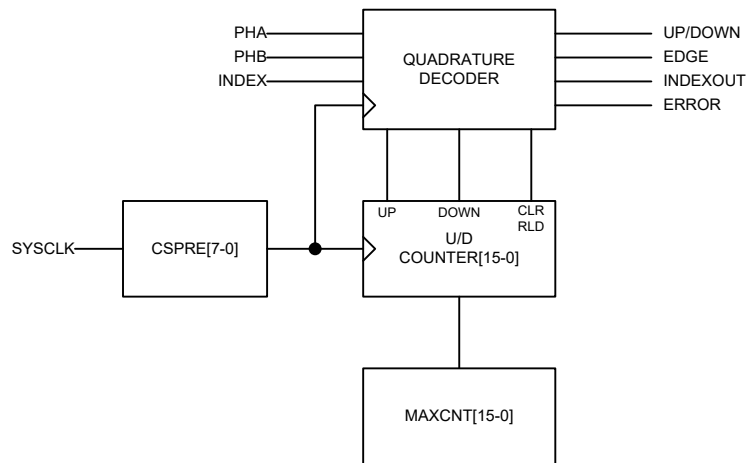

Figure 11-3 QE implementation diagram

QE Counter is in signed integer format, the MSB (Bit 15) indicates the sign, and reload action causes the counter to load a default value 0x8000. The corresponding maximum count register thus only have 15 valid bits, MSB bit 15 is not used. The reload action is triggered either by external INDEX event or terminal count condition when counter absolute value reaches (equals) to MAXCNT value.

QECFG1 (0xA070h) TCC Configuration Register 1 R/W (0x00)

	7	6	5	4	3	2	1	0
RD	QEMODE[1-0]		QECS[1-0]		SWAP	DBCS[2-0]		
WR	QEMODE[1-0]		QECS[1-0]		SWAP	DBCS[2-0]		

MODE[1-0]

QE Mode
 00 – Disable QE
 01 – 1X mode
 10 – 2X mode
 11 – 4X mode

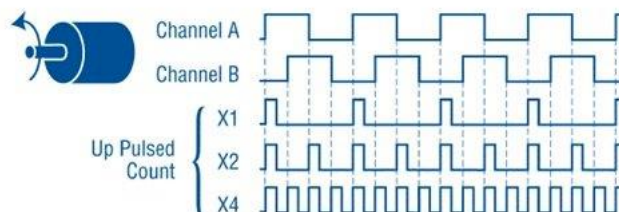

Figure 11-4 Timing diagram of CHA/CHB with X1/X2/X4 modes

QECS[1-0]	QE Clock Scaling
	00 SYSCLK/4
	01 SYSCLK/16
	10 SYSCLK/64
	11 SYSCLK/256
SWAP	Swap PHA and PHB
DACS[2-0]	De-Bounce Clock Scaling
	000 Disable de-bounce
	001 SYSCLK/2
	010 SYSCLK/4
	011 SYSCLK/8
	100 SYSCLK/16
	1/32 SYSCLK/32
	1/64 SYSCLK/64
	1/128 SYSCLK/128
	1/256 SYSCLK/256
	De-bounce time is three DACS period.

QECFG2 (0xA071h) QE Configuration Register 2 R/W (0x00)

	7	6	5	4	3	2	1	0
RD	DIR	ERRF	RLDM[1-0]		TCF	IDXF	DIRF	CNTF
WR	-	ERRF	RLDM[1-0]		TCF	IDXF	DIRF	CNTF

DIR	Direction Status Indicate UP/DOWN direction.
ERRF	Phase Error Flag ERRF is set to 1 by hardware if PHA and PHB change value at the same time. ERRF must be cleared by software.
RLDM[1-0]	QE Counter Reload Mode RLDM[1-0] = 00 No Reload, QECNT will count up/down cycling through 0x0000 or 0xFFFF RLDM[1-0] = 01 Reload using Index event. Reload QECNT=0 when Index==1 && UP Reload QECNT=QEMAX when Index==1 && DOWN RLDM[1-0] = 10 Reload using TC event. Reload QECNT=0 when QECNT==QEMAX && UP Reload QECNT=QEMAX when QECNT==0 && DOWN RLDM[1-0] = 11 Reload using both Index and TC events Combine Index and TC events and reload whichever occurs first.
TCF	TC Event Interrupt Flag TCF is set by hardware when a TC event interrupt has occurred. TCF needs to be cleared by software by writing "0".
IDXF	Index Event Interrupt Flag IDXF is set by hardware when an Index event interrupt has occurred. IDXF needs to be cleared by writing "0".
DIRF	Direction Change Event Interrupt Flag IRF is set by hardware when a Direction change event interrupt has occurred. DIRF needs to be cleared by writing "0".
CNTF	Count Change Event Interrupt Flag CNTF is set by hardware when a QE count change event interrupt has occurred. CNTF needs to be cleared by writing "0".

QECFG3 (0xA072h) QE Configuration Register 3 R/W (0x00)

	7	6	5	4	3	2	1	0
RD	IENTC	IENIDX	IENDIR	IENCNT	IENERR	IDXEN	IDXM[1-0]	
WR	IENTC	IENIDX	IENDIR	IENCNT	IENERR	IDXEN	IDXM[1-0]	

IS32CS8975

IEN TC	Interrupt Enable for TC TC condition for QE is defined as the following conditions. 1 QECNT=QEMAX when UP 2 QECNT=0 when down
IENIDX	Interrupt Enable for Index event
IEN DIR	Interrupt Enable for Direction change
IEN CNT	Interrupt Enable for any QECNT change
IDXEN	Index Input Enable IDXEN=0 gates out of the external INDEX input and is gated to 0. IDXEN=1 allows external INDEX.
IDXM[1-0]	Index Match Selection. This is applicable only for X2 and X4 modes. 00 = up phase 00 → 10 ; down phase 10 → 00 01 = up phase 10 → 11 ; down phase 11 → 10 10 = up phase 01 → 00 ; down phase 00 → 01 11 = up phase 11 → 01 ; down phase 01 → 11

QECNTL (0xA074h) QE Counter LOW R/W (0x00)

	7	6	5	4	3	2	1	0
RD	QECNT[7-0]							
WR	QECNTINI[7-0]							

QECNTH (0xA075h) QE Counter High R/W (0x00)

	7	6	5	4	3	2	1	0
RD	QECNT[15-8]							
WR	QECNTINI[15-8]							

Reading QECNT will return the current QE counter value. Writing QECNT will set the current count value. Writing QECNT is allowed only when QE is in disabled state.

QEMAXL (0xA076h) QE Counter Low R/W (0x00)

	7	6	5	4	3	2	1	0
RD	QEMAX[7-0]							
WR	QEMAX[7-0]							

QEMAXH (0xA077h) QE Counter High R/W (0x00)

	7	6	5	4	3	2	1	0
RD	QEMAX[15-8]							
WR	QEMAX[15-8]							

QEMAX holds the maximum count of the QE counter. When QEMAX is reached, a TC event is triggered and QE counter is reloaded.

IS32CS8975

12. PWM Controller

PWM controller provides programmable 6 channels 12/10/8 bit PWM center-aligned duty cycle outputs. The counting clock of PWM is programmable and the base frequency of the PWM is just the counting clock divided by 8192/2048/512 for 12/10/8 bit configurations due to center-alignment counting. PWM outputs are multiplexed with GPIO ports.

PWMCFG1 (0xA080h) PWM Clock Scaling Setting Register R/W (0x00)

	7	6	5	4	3	2	1	0
RD	PWMEN	MODE[1-0]			CS[4-0]			
WR	PWMEN	MODE[1-0]			CS[4-0]			

PWMEN PWM Controller Enable
 PWMEN=0 clears the counter, reset the PWM state and all channel outputs are forced to 0.
 PWMEN=1 allows normal running operation of PWM controller.

MODE[1-0] PWM Resolution Select
 00 = 8-bit
 01 = 10-bit
 10 = 12-bit
 11 = Reserved

CS[4-0] PWM Counting Clock Scaling
 The counting clock is $SYSCLK/(CS[4-0]+1)$

PWMCFG2 (0xA081h) PWM Interrupt Enable and Flag Register R/W (0x00)

	7	6	5	4	3	2	1	0
RD	ZTRGEN	CTRGEN	ZINTEN	CINTEN	-	-	ZINTF	CINTF
WR	ZTRGEN	CTRGEN	ZINTEN	CINTEN	-	-	ZINTF	CINTF

ZTRGEN Zero ADC Trigger Enable

CTRGEN Center ADC Trigger Enable

ZINTEN Zero Interrupt Enable
 ZINTEN=1 allows PWM Controller to generate an interrupt when counter is 0.

CNTEN Center Interrupt Enable
 CINTEN=1 allows PWM Controller to generate an interrupt when counter is at the middle value.

ZINTF Zero Interrupt Flag
 ZINTF is set to 1 by hardware to indicate a Zero interrupt has occurred. ZINTF must be cleared by software.

CINTF Center Interrupt Flag
 CINTF is set to 1 by hardware to indicate a Center interrupt has occurred. CINTF must be cleared by software.

PWMCFG3 (0xA082h) PWM Configuration 3 Register R/W (0x00)

	7	6	5	4	3	2	1	0
RD	PRSEN	SYNC	POL[5-0]					
WR	PRSEN	SYNC	POL[5-0]					

PRSEN Pseudo-Random Sequence Enable
 PRSEN=1 will enable a pseudo random sequence toward the PWM output width. This can be an effective way to reduce EMI for output. When PRSEN=1, the instantaneous duty cycle will be affected cycle by cycle, but the average duty cycle remains the same.

SYNC Channel Synchronize
 Writing SYNC=1 will cause the loading of duty register on the nextcount=0 event. The purpose of this is to synchronize the timing of all the PWM channels. SYNC is cleared by hardware after reloading is completed.
 Reading SYNC by software can tell whether reload has been in effect or not.

POL[5-0] Channel Polarity Control
 POL[J] = 0 for normal polarity and POL[J]=1 for reverse polarity.

IS32CS8975

There are 6 PWMDTY registers to define the duty cycle of each PWM channel. If PWMDTY = 0, the output is 0. If PWMDTY = full, the output duty cycle is maximum to (period – 1)/period. PWMDTY is always double buffered and is loaded to duty cycle comparator when the SYNC bit is set and current counting cycle is completed. PWMDTY[7-0] is used for 8-bit PWM output, PWMDTY[9-0] is used for 10-bit, and PWMDTY[11-0] is used for 12-bit. Please note if PWMEN=0 (PWM is disabled), then writing to PWMDTY register is immediate active.

PWM0DTYL (0xA084h) PWM0 Duty Register L R/W (0x00)

	7	6	5	4	3	2	1	0
RD	PWM0DTY[7-0]							
WR	PWM0DTY[7-0]							

PWM0DTYH (0xA085h) PWM0 Duty Register H R/W (0x00)

	7	6	5	4	3	2	1	0
RD	-	-	-	-	PWM0DTY[11-8]			
WR	-	-	-	-	PWM0DTY[11-8]			

PWM1DTYL (0xA086h) PWM1 Duty Register L R/W (0x00)

	7	6	5	4	3	2	1	0
RD	PWM1DTY[7-0]							
WR	PWM1DTY[7-0]							

PWM1DTYH (0xA087h) PWM1 Duty Register H R/W (0x00)

	7	6	5	4	3	2	1	0
RD	-	-	-	-	PWM1DTY[11-8]			
WR	-	-	-	-	PWM1DTY[11-8]			

PWM2DTYL (0xA088h) PWM2 Duty Register L R/W (0x00)

	7	6	5	4	3	2	1	0
RD	PWM2DTY[7-0]							
WR	PWM2DTY[7-0]							

PWM2DTYH (0xA089h) PWM2 Duty Register H R/W (0x00)

	7	6	5	4	3	2	1	0
RD	-	-	-	-	PWM2DTY[11-8]			
WR	-	-	-	-	PWM2DTY[11-8]			

PWM3DTYL (0xA08Ah) PWM3 Duty Register L R/W (0x00)

	7	6	5	4	3	2	1	0
RD	PWM3DTY[7-0]							
WR	PWM3DTY[7-0]							

PWM3DTYH (0xA08Bh) PWM3 Duty Register H R/W (0x00)

	7	6	5	4	3	2	1	0
RD	-	-	-	-	PWM3DTY[11-8]			
WR	-	-	-	-	PWM3DTY[11-8]			

PWM4DTYL (0xA08Ch) PWM3 Duty Register L R/W (0x00)

	7	6	5	4	3	2	1	0
RD	PWM4DTY[7-0]							
WR	PWM4DTY[7-0]							

IS32CS8975

PWM4DTYH (0xA08Dh) PWM3 Duty Register H R/W (0x00)

	7	6	5	4	3	2	1	0
RD	-	-	-	-	PWM4DTY[11-8]			
WR	-	-	-	-	PWM4DTY[11-8]			

PWM5DTYL (0xA08Eh) PWM5 Duty Register LR/W (0x00)

	7	6	5	4	3	2	1	0
RD	PWM5DTY[7-0]							
WR	PWM5DTY[7-0]							

PWM5DTYH (0xA08Fh) PWM5 Duty Register H R/W (0x00)

	7	6	5	4	3	2	1	0
RD	-	-	-	-	PWM5DTY[11-8]			
WR	-	-	-	-	PWM5DTY[11-8]			

IS32CS8975

13. Buzzer and Melody Controller

The buzzer and melody controller can be used to generate a simple buzzer sound or a single tone melody. It contains a two note Ping-Pong buffer, each with programmable tone frequency, and duration/pause timer. The tone frequency is derived from SYSCLK divided by either 32 or 64, and the tone frequency is generated with resolution of 12-bit to support precision tone generation with wide octave span. The duration/pause timers can be programmed in 1ms/2ms/4ms/8ms steps. The two notes can be played sequentially once or can be played as Ping-Pong styles for melody. A POW (Power On Width) timer is also programmed in 1ms/2ms/4ms/8ms steps. POW timer can be used to generate external power control of the buzzer element. After either note A or B is started, POW timer will start.

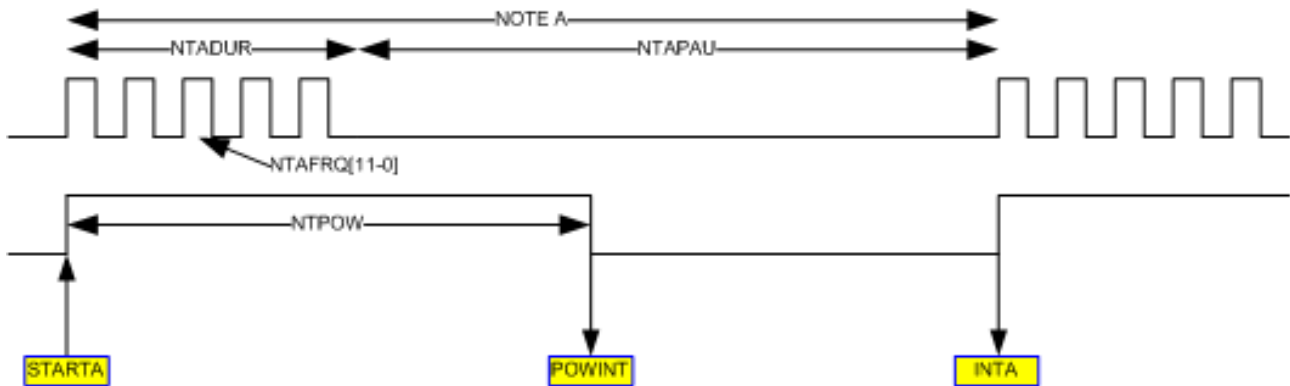

Figure 13-1 Buzzer and Melody output timing diagram

NTAFRQL (0xA040h) Note A Frequency Register R/W (0x00)

	7	6	5	4	3	2	1	0
RD	NTAFRQ[7-0]							
WR	NTAFRQ[7-0]							

NTAFRQH (0xA041h) Note A Frequency Register R/W (0x00)

	7	6	5	4	3	2	1	0
RD	-		-			NTAFRQ[11-8]		
WR	-		-			NTAFRQ[11-8]		

Tone frequency is $\text{SYSCLK}/(32 \text{ or } 64)/(\text{NTAFRQ}[11-0]+1)$.

NTADUR (0xA042h) Note A Duration Register R/W (0x00)

	7	6	5	4	3	2	1	0
RD	NTADUR[7-0]							
WR	NTADUR[7-0]							

Tone duration is $\text{TU} * \text{NTADUR}[7-0]$

NTAPAU (0xA043h) Note A Pause Register R/W (0x00)

	7	6	5	4	3	2	1	0
RD	NTAPAU[7-0]							
WR	NTAPAU[7-0]							

Tone pause is $\text{TU} * \text{NTAPAU}[7-0]$

NTBFRQL (0xA044h) Note B Frequency Register R/W (0x00)

	7	6	5	4	3	2	1	0
RD	NTBFRQ[7-0]							
WR	NTBFRQ[7-0]							

NTBFRQH (0xA045h) Note B Frequency Register R/W (0x00)

	7	6	5	4	3	2	1	0
RD	-		-		NTBFRQ[11-8]			
WR	-		-		NTBFRQ[11-8]			

NTBDUR (0xA046h) Note B Duration Register R/W (0x00)

	7	6	5	4	3	2	1	0
RD	NTBDUR[7-0]							
WR	NTBDUR[7-0]							

NTBPAU (0xA047h) Note B Pause Register R/W (0x00)

	7	6	5	4	3	2	1	0
RD	NTBPAU[7-0]							
WR	NTBPAU[7-0]							

NTPOW (0xA049h) Note Power On Window Register R/W (0x00)

	7	6	5	4	3	2	1	0
RD	NTPOW [7-0]							
WR	NTPOW [7-0]							

NTPOW defines a timer after either STARTA or STARTB. It uses the same time unit as duration and pause. When the timer expires, it generates an interrupt by setting INTFP bit.

NTTU (0xA04Ah) Note Time Unit Register R/W (0x00)

	7	6	5	4	3	2	1	0
RD	TU[1-0]		-	TBASE	-	-	INTEPOW	INTFP
WR	TU[1-0]		-	TBASE	-	-	INTEPOW	INTFP

TU[1-0]

Time Unit

TU[1-0] defines the time unit for duration, pause, and POW timer. This is derived from SOSC32KHz and not dependent on tone frequency setting.

00 = 1 msec

01 = 2 msec

10 = 4 msec

11 = 8 msec

TBASE

Tone Base Frequency Select

TBASE=0 uses SYSCLK/32 as base

TBASE=1 uses SYSCLK/64 as base

INTEPOW

POW Timer Interrupt Enable

INTFP

POW Interrupt Flag

INTFP is set by hardware when POW timer expires. It must be cleared by software.

BZCFG (0xA048h) Buzzer Configure Register R/W (0x00)

	7	6	5	4	3	2	1	0
RD	BZEN	BZPOL	INTENB	INTENA	INTFB	INTFA	BUSYB	BUSYA
WR	BZEN	BZPOL	INTENB	INTENA	INTFB	INTFA	STARTB	STARTA

BZEN

Buzzer Control Enable

BZEN=1 enables the buzzer controller.

BZEN=0 disables the buzzer controller.

BZPOL

BZOUT Polarity Setting

BZPOL=1, BZOUT is inverted.

BZPOL=0, BZOUT has normal polarity.

INTENB

Note B End Interrupt Enable

INTENB=1 enables the note B end interrupt. The interrupt is triggered when note B playing is completed.

INTENA	Note A End Interrupt Enable INTENA =1 enables the note A end interrupt. The interrupt is triggered when note A playing is completed.
INTFB	Note B End Interrupt Flag INTFB is set to 1 by hardware if INTENB=1 and note B playing ends. INTFB needs to be cleared by writing 0.
INTFA	Note A End Interrupt Flag INTFA is set to 1 by hardware if INTENA=1 and note A playing ends. INTFA needs to be cleared by writing 0.
STARTB	Note B Start Command Writing STARTB=1 initiates a session output on the buzzer. Writing 0 to STARTB has no effect. STARTB is self-cleared when the note is completed.
STARTA	Note A Start Command Writing STARTA=1 initiates a session output on the buzzer. Writing 0 to STARTA has no effect. STARTA is self-cleared when the note is completed.
*** Note: If STARTA and STARTB are set to 1 at the same time, then Note A is played first followed by note B. Software can do this for a simple two-notes melody.	
BUSYB	Note B is playing busy status. BUSYB is set to 1 by hardware when the output is active playing note B.
BUSYA	Note A is playing busy status. BUSYA is set to 1 by hardware when the output is active playing note A.

IS32CS8975

14. Core Regulator and Low Voltage Detection

An on-chip serial regulator converts VDD into VDDC for internal circuit supply voltage. Typical value for VDDC is 1.5V at normal mode. In sleep mode, a backup regulator with typical value of 1.3V supplies VDDC. The VDDC can be trimmed and the calibrated trim value for 1.5V is stored in IFB during the manufacture test.

REGTRM (0xA000h) Regulator Trim Register R/W (0x80) TB protected

	7	6	5	4	3	2	1	0
RD	REGTRM[7-0]							
WR	REGTRM[7-0]							

14.1 Supply Low Voltage Detection (LVD)

The supply Low Voltage Detection (LVD) circuit detects VDD < VTH condition and can be used to generate an interrupt or a reset. LVD defaults to be at disabled state to save power. An enabled LVD circuit consumes about 100uA to 200uA. The LVDTHD[6-0] sets the compare threshold according to the following equation when LVDTHV is the detection voltage.

$$\begin{aligned} \text{LVDTHV} &= \text{VDDC} * (1 + 2 * (1 - \text{LVDTHD}[6-0]/128)) \\ &= 1.5 + 3 * (1 - \text{LVDTHD}[6-0]/128), \text{ if VDDC is calibrated to 1.5V.} \end{aligned}$$

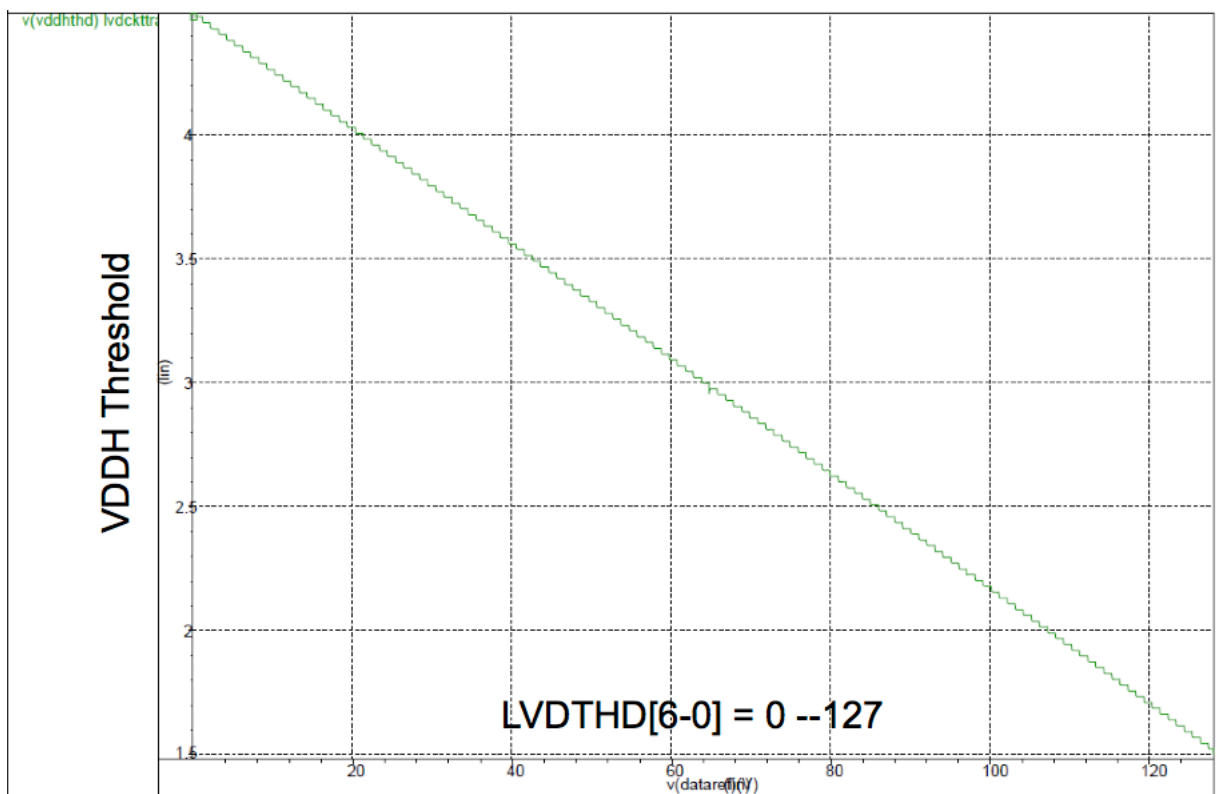

Figure 14-1 LVD Threshold VX LVDTHD[6-0]

LVDCFG (0xA010h) Supply Low Voltage Detection Configuration Register R/W (0x08) TB Protected except bit 0 LVTIF

	7	6	5	4	3	2	1	0
RD	LV DEN	LV REN	LV TEN	LV DFLTEN	-	-	-	LVTIF
WR	LV DEN	LV REN	LV TEN	LV DFLTEN	-	-	-	LVTIF

LV DEN LVD Enable bit. Set to turn on supply voltage detection circuits.
 LV REN LVR Enable bit. LV REN = 1 allows low voltage detect condition to cause a system reset.
 LV TEN LVT Enable bit. LV TEN = 1 allows low voltage detect condition to generate an interrupt.
 LV DFLTEN LVD Filter Enable

LVTIF

LVDFLTEN = 1 enables a noise filter on the supply detection circuits. The filter is set at around 30 usec.

Low Voltage Detect Interrupt Flag

LVTIF is set by hardware when LVD detection occurs and must be cleared by software.

LVDTHD (0xA011h) Supply Low Voltage Detection Threshold Register R/W (0bx1111111) TB Protected

	7	6	5	4	3	2	1	0
RD	-	LVDTHD6	LVDTHD5	LVDTHD4	LVDTHD3	LVDTHD2	LVDTHD1	LVDTHD0
WR	-	LVDTHD6	LVDTHD5	LVDTHD4	LVDTHD3	LVDTHD2	LVDTHD1	LVDTHD0

LVDTHD = 0x00 will set the detection threshold at its maximum, and LVDTHD = 0x7F will set the detection threshold at its minimum.

LVDHYS (0xA012h) Supply Low Voltage Detection Threshold Hysteresis Register R/W (0x00) TB Protected

	7	6	5	4	3	2	1	0
RD	LVDHYEN	LVDHYS6	LVDHYS5	LVDHYS4	LVDHYS3	LVDHYS2	LVDHYS1	LVDHYS0
WR	LVDHYEN	LVDHYS6	LVDHYS5	LVDHYS4	LVDHYS3	LVDHYS2	LVDHYS1	LVDHYS0

To ensure a solid Low Voltage detection, a digitally controlled hysteresis is used. If LVDHYEN=1, LVD is asserted as a new threshold defined by LVDHYS[6-0] instead of LVDTHD[6-0]. In typical applications, LVDHYS[6-0] should be set to be smaller than LVDTHD[6-0], such that the recovery voltage is higher than the detection voltage.

IS32CS8975

15. IOSC and SOSC

15.1 IOSC 16MHz/32MHz

An on-chip 16MHz/32MHz Oscillator with low-temperature coefficient provides the system clock to the CPU and other logic circuits. IOSC uses VDD15 as supply and can be calibrated and trimmed. The accuracy of the frequency is +/- 2% within the operating conditions. This oscillator is stopped and enters standby mode when CPU is in STOP/SLEEP mode and resumes oscillation when CPU wakes up.

IOSCITRM (0xA001h) IOSC Coarse Trim Register R/W (0x01) TB Protected

	7	6	5	4	3	2	1	0
RD	SSC[3-0]				SSA[1-0]		ITRM[1-0]	
WR	SSC[3-0]				SSA[1-0]		ITRM[1-0]	

SSC[3-0] SSC[3-0] defines the spread spectrum sweep rate. If SSC[3-0] = 0000, then the spread spectrum is disabled.

SSA[1-0] SSA[1-0] defines the amplitude range of spread spectrum frequency. The frequency is changed by adding SSA[1-0] range to the actual IOSCVTRM[7-0].
 SSA[1-0] = 11, +/- 32
 SSA[1-0] = 10, +/- 16
 SSA[1-0] = 01, +/- 8
 SSA[1-0] = 00, +/- 4

ITRM[1-0] ITRM[1-0] is the coarse trimming of the IOSC.

IOSCVTRM (0xA002h) IOSC Fine Trim Register R/W (0x80) TB Protected

	7	6	5	4	3	2	1	0
RD	IOSCVTRM[7-0]							
WR	IOSCVTRM[7-0]							

This register provides fine trimming of the IOSC frequency. The higher the value of IOSCVTRM, the lower the frequency is.

The manufacturer trim value is stored in IFB and is trimmed to 16MHz. The user program provides the freedom to set the IOSC at a preferred frequency if the program is able to calibrate the frequency. Once set, the IOSC frequency has an accuracy deviation within +/- 2% over the operation conditions. The following lists the range of the typical IOSC frequency for each trimming setting.

- ITRM[1:0] = 2'b11, IOSC=27.4—36.8MHz
- ITRM[1:0] = 2'b10, IOSC=25.5—34.3MHz
- ITRM[1:0] = 2'b01, IOSC=14.1—19.2MHz
- ITRM[1:0] = 2'b00, IOSC=12.2—16.5MHz

A hardware Spread Spectrum can be enabled for the IOSC. This is controlled by SSC[3-0]. When SSC[3-0] = 0, the spread spectrum is disabled, and IOSC functions normally as a fixed-frequency oscillator. If SSC[3-0] is not 0, then Spread Spectrum is enabled and IOSC frequency is swept according to the setting of SSC[3-0] and SSA[1-0]. The spread is achieved by varying the actual VTRM output to the oscillator circuit, thus effectively changing the oscillation frequency. The effect of SSC[3-0] and SSA[1-0] is shown in the following graph.

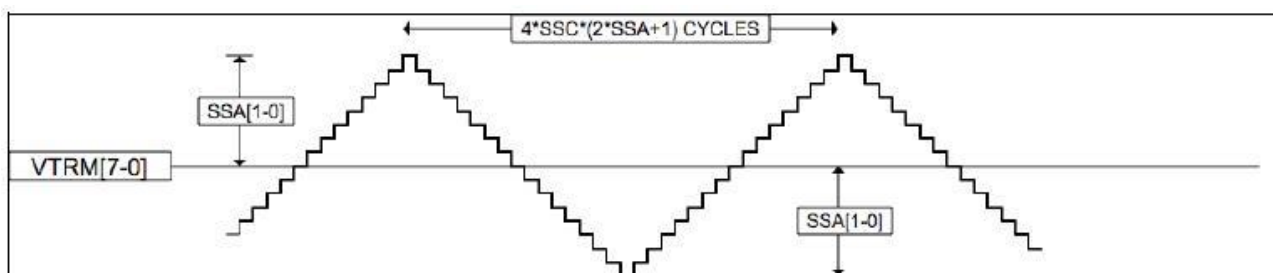

Figure 15-1 IOSC sweep rate and amplitude of Spread Spectrum

When Spread Spectrum is enabled, the actual controlling output to IOSC is VTRM[7-0] +/- SSA. This is shown in the graph above as the bold curve. The above example shows SSA[1:0] = 01, and the deviation is +/- 8.

IS32CS8975

SSC[3-0] defines the update time in IOSC cycles. Then we can calculate the period of a complete sweep is $4 * SSC * (2 * SSA + 1)$ IOSC cycles, and we can obtain the sweep frequency from this period. When SS is enabled, the frequency of IOSC varies according to time and setting, and therefore the accuracy of IOSC frequency cannot be guaranteed. Please also note that VTRMOUT is VTRM[7-0] +/- SSA but is bounded by 0 and 255. Therefore, for a linear non-clipped sweep, VTRM[7-0] needs to be within the range of SSA ~ (256-SSA), for example, SSA[10] = 01, then SSA is 8. VTRM[7-0] should be in the range from 8 to 248 to prevent the sweep from being clipped. As Spread Spectrum suggests, the total EMI energy is not reduced, but the energy is spread over a wider frequency. It is recommended that SS usage should be carefully evaluated and the setting of spread amplitude and the sweep frequency should be chosen carefully for reducing the EMI effect.

15.2 SOSC 128KHz

A 128KHz ultra-low power slow oscillator is also included. SOSC consumes less than 0.5uA from VDDC and is always enabled. The system uses SOSC/4 = 32KHz for system clock, wake-up timer T5, and WDT2/WDT3. SOSC is not very accurate and varies chip to chip, but it is relatively immune to supply voltage and temperature variance. Therefore, software can use IOSC to calibrate SOSC through SOSCTRM[4-0]. Default design characteristics are shown: SOSCTRM=5b'1_1111/SOSC = 158KHz, 5b'1_0000/SOSC=126KHz, 5b'0_0000/SOSC=105KHz.

SOSCTRM (0xA007h) SOSC Trim Register R/W (0x10) TB Protected

	7	6	5	4	3	2	1	0	
RD	-					SOSCTRM[4-0]			
WR	-	-				SOSCTRM[4-0]			

IS32CS8975

16. 11-Bit SAR ADC (ADC)

The on-chip ADC is an 11-bit SAR based ADC with maximum ADC clock rate of 4MHz (2.5V – 5V) or 500KHz (1.8V – 2.4V). The ADC uses VDDC (1.5V typical) as full-scale reference. Typical ADC accuracy is about 9.5 bit to 10 bit at 1.5V reference with input range between 0.2V to 1.5V. The ADC has four intrinsic channels. CHA and CHB are further connected to GPIO's analog I/O switches to expand multiplexed inputs. TPS is connected to internal temperature sensor (a diode connected NPN) with negative temperature coefficient. VPS is 1/5th of VDD. When VPS is enabled, ADC consumes about 1mA current. The ADC also includes hardware to perform average readout results. The average can be set to 1 to 8 times. The block diagram of ADC is shown in the following.

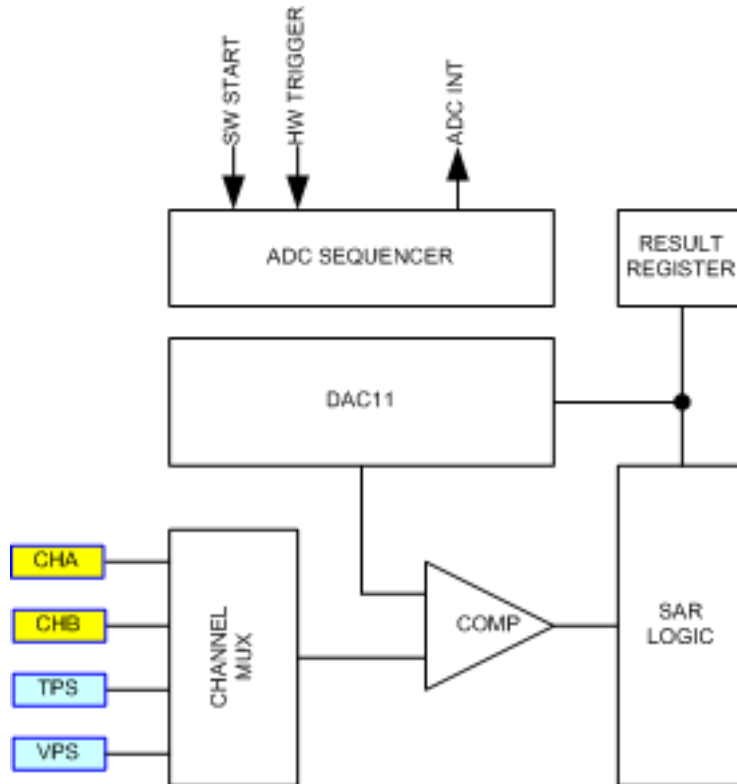

Figure 16-1 11-bit SAR ADC block diagram

ADCCFG (0xA9h) ADC Configuration Register R/W (0x00)

	7	6	5	4	3	2	1	0
RD	ADCEN	ADCINTE	ADCFM	-	-	PRE[2-0]		
WR	ADCEN	ADCINTE	ADCFM	-	-	PRE[2-0]		

ADCEN

ADC Enable bit

ADCEN=1 enables ADC.

ADCEN=0 puts ADC into power down mode.

When ADCEN is set from 0 to 1, the program needs to wait at least 20us to allow analog bias to stabilize to ensure ADC's proper functionality.

ADCINTE

ADC Interrupt Enable bit

ADCINTE=1 enables the ADC interrupt when conversion completes.

ADCINTE=0 disables the ADC interrupt.

ADCFM

ADC Result Format Control bit

ADCFM = 1 sets ADC result as MSB justified. ADCH contains the MSB bits of the result. ADCL[7-5] contains LSB results and ADCL[4-0] is filled with 0000.

ADCFM = 0 sets ADC result as LSB justified. ADCH[7-3] is filled with 0000. ADCH [2-0] contains MSB result. ADCL contains the LSB results.

PRE[2-0]

ADC Clock Divider

PRE[2-0]	ADC CLOCK
000	SYSCLK/2

PRE[2-0]	ADC CLOCK
001	SYSCLK/4
010	SYSCLK/8
011	SYSCLK/16
100	SYSCLK/32
101	SYSCLK/64
110	SYSCLK/128
111	SYSCLK/256

ADCCTL (0xCEh) ADC Control Register R/W (0x00)

	7	6	5	4	3	2	1	0
RD	AVG[1-0]		CHSEL[1-0]		-		ADCIF	CSTART
WR	AVG[1-0]		CHSEL[1-0]		-		-	CSTART

AVG[1-0]

AVG[1-0] controls the hardware averaging logic of ADC readout. It is recommended the setting is changed only when ADC is stopped. If multiple channels are enabled, then each channel is averaged in sequence. The default is 00.

AVG1	AVG0	ADC Result
0	0	1 Times Average
0	1	2 Times Average
1	0	4 Times Average
1	1	8 Times Average

CHSEL[1-0]

ADC Channel Select

CHSEL[1]	CHSEL[0]	ADC Channel
0	0	CHA
0	1	CHB
1	0	Temperature
1	1	1/5 VDD

ADCIF

ADC Conversion Completion Interrupt Flag bit

ADCIF is set by hardware when the conversion is completed and new result is written to ADCL and ADCH result registers. If ADC interrupt is enabled, there could generate an interrupt. This bit is cleared when ADCL is read. When this flag is set, no new conversion result is updated.

CSTART

Software Start Conversion bit

Set this CSTART=1 to trigger an ADC conversion on selected channels. This bit is self-cleared when the conversion is done.

ADCH and ADCL are the high and low byte result registers respectively and are read-only. Reading low byte result in clearing its corresponding interrupt flag. If the flag is not cleared, no new result is updated. The software should always read the low byte as the last procedure. The format of the high byte and low byte depends on ADCFM setting.

If ADCFM = 1, the valid ADC Result is located on ADCH[7-0] and ADCL[3-0]. If ADCFM = 0, the valid ADC Result is located on ADCH[3-0] and ADCL[7-0].

ADCL (0xBAh) ADC Result Register Low Byte RO (0xXX)

	7	6	5	4	3	2	1	0
RD	ADCL[7-0]							
WR	-							

IS32CS8975

ADCH (0xBBh) ADC Result Register High Byte RO (0xXX)

	7	6	5	4	3	2	1	0
RD	ADCH[7-0]							
WR	-							

IS32CS8975

17. Analog Comparators (ACMP) and 8-bit DAC

There are four analog comparators as its on-chip external peripherals. When enabled, each comparator consumes about 40uA. The input signal range is from 0 to VDD. There are two 8-bit R-2R DAC associated with the comparators to generate the comparison threshold. The R-2R DAC uses the internal 1.5V supply as the full-scale range, and thus limits the comparator threshold from 0V to 1.5V in 256 steps. Comparator A can select either VTH0 or VTH1 as the threshold. Comparator B/C/D can select between VTH0 and external threshold. VTH1 is also sent to a unity gain buffer for use as a DAC output. The buffer can supply or sink up to 150uA. Individual comparator when enabled consumes about 40uA/each, and the unity gain buffer consumes about 60uA/80uA under 3V/5V supply conditions.

The CPU can read the real-time outputs of the comparator directly through register access. The output is also sent to an edge-detector and any edge transition can be used to trigger an interrupt. The stabilization time from off state to enabled state of the comparator block is about 20usec. The block diagram of the analog comparator is shown in the following diagram.

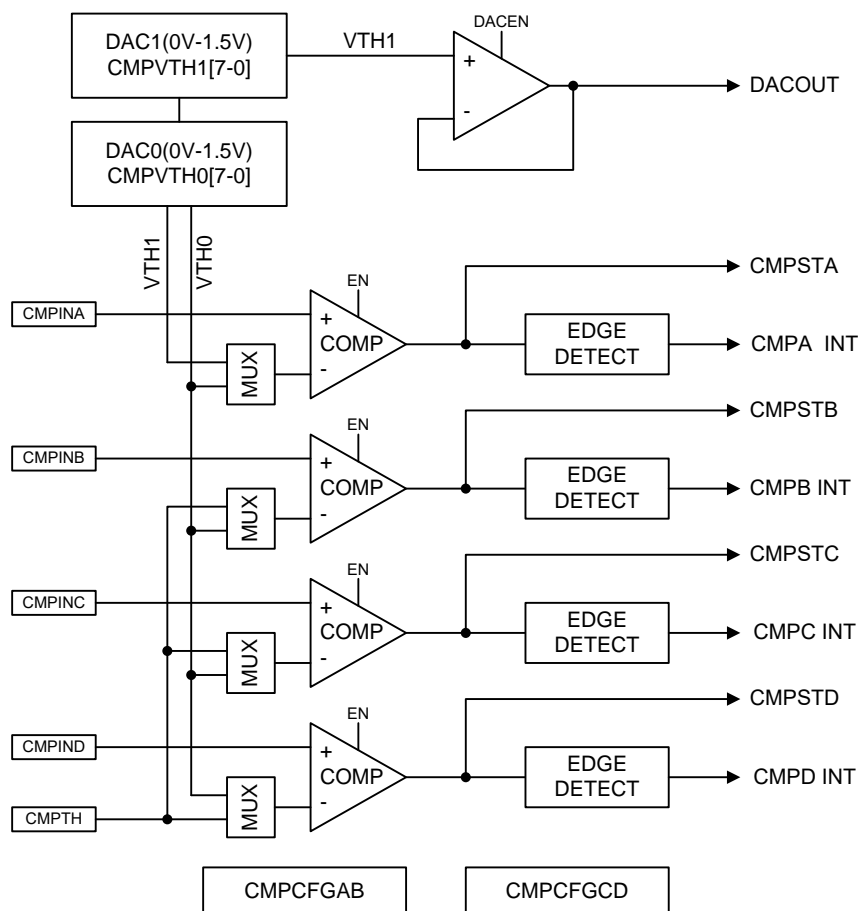

Figure 17-1 ACMP and 8-bit DAC block diagram

CMPCFGAB (0xA038h) Analog Comparator A/B Configuration Register R/W (0x00)

	7	6	5	4	3	2	1	0
RD	CMPENA	THSELA	INTENA	POLA	CMPENB	THSELB	INTENB	POLB
WR	CMPENA	THSELA	INTENA	POLA	CMPENB	THSELB	INTENB	POLB

- CMPENA Comparator A Enable bit. Set to enable the comparator. When CMPENA is set from 0 to 1, software needs to wait at least 20us to allow analog bias to stabilize to ensure comparator A's proper functionality.
- THSELA Comparator A Threshold Select bit. THSELA = 0, the comparator A uses VTH0 as the threshold. THSELA = 1, comparator A uses VTH1 as the threshold.
- INTENA Set to enable the comparator A's interrupt.
- POLA Channel A Output polarity control bit. Set POLA=0 as default polarity.

CMPENB	Set POLA=1 to reverse the output polarity of the comparator. Comparator B Enable bit. Set to enable the comparator. When CMPENB is set from 0 to 1, software needs to wait at least 20us to allow analog bias to stabilize to ensure comparator B's proper functionality.
THSELB	Comparator B Threshold Select Bit. If THSELB = 0, the comparator B uses VTH0 as the threshold. If THSELB = 1, comparator B uses external threshold.
INTENB	Set to enable comparator B's interrupt.
POLB	Channel B Output polarity control bit Set POLB=0 as default polarity. Set POLB=1 to reverse the output polarity of the comparator.

CMPCFGCD (0xA039h) Analog Comparator C/D Configuration Register R/W (0X00)

	7	6	5	4	3	2	1	0
RD	CMPENC	THSELC	INTENC	POLC	CMPEND	THSELD	INTEND	POLD
WR	CMPENC	THSELC	INTENC	POLC	CMPEND	THSELD	INTEND	POLD

CMPENC	Comparator C Enable Bit. Set to enable the comparator. When CMPENC is set from 0 to 1, software needs to wait at least 20us to allow analog bias to stabilize to ensure comparator C's proper functionality.
THSELC	Comparator C Threshold Select Bit. If THSELC = 0, the comparator C uses VTH0 as the threshold. If THSELC = 1, comparator C uses external threshold.
INTENC	Set to enable the comparator C interrupt.
POLC	Channel C Output polarity control bit Set POLC=0 as default polarity. Set POLC=1 to reverse the output polarity of the comparator.
CMPEND	Comparator D Enable Bit. Set to enable the comparator. When CMPEND is set from 0 to 1, software needs to wait at least 20us to allow analog bias to stabilize to ensure comparator D's proper functionality.
THSELD	Comparator D Threshold Select Bit. If THSELD = 0, the comparator D uses VTH0 as the threshold. If THSELD = 1, comparator D uses external threshold.
INTEND	Set to enable the comparator D interrupt.
POLD	Channel D Output polarity control bit Set POLD=0 as default polarity. Set POLD=1 to reverse the output polarity of the comparator.

CMPVTH0 (0xA03Ah) Analog Comparator Threshold Control Register R/W (0x00)

	7	6	5	4	3	2	1	0
RD	VTH0 Register							
WR	VTH0 Register							

CMPVTH0 register controls the comparator threshold VTH0 through an 8-bit DAC. When set to 0x00h, the threshold is 0V. When set to 0xFFh, the threshold is at 1.5V. When not used, it should be set to 0x00 to save power consumption.

CMPVTH1 (0xA03Bh) Analog Comparator Threshold Control Register R/W (0x00)

	7	6	5	4	3	2	1	0
RD	VTH1 Register							
WR	VTH1 Register							

CMPVTH1 register controls the comparator threshold VTH1 through an 8-bit DAC. When set to 0x00h, the threshold is 0V. When set to 0xFFh, the threshold is at 1.5V. When not used, it should be set to 0x00 to save power consumption. VTH1's DAC level is also used for DAC voltage output.

CMPST (0xA03Dh) Analog Comparator Status Register R/W (0x00)

	7	6	5	4	3	2	1	0
RD	CMPIFD	CMPIFC	CMPIFB	CMPIFA	CMPSTD	CMPSTC	CMPSTB	CMPSTA
WR	CMPIFD	CMPIFC	CMPIFB	CMPIFA	FILEND	FILENC	FILENB	FILENA

CMPIFD	Comparator D Interrupt Flag bit. This bit is set when CMPSTD is toggled, and the comparator D setting is enabled. This bit must be cleared by software.
CMPIFC	Comparator C Interrupt Flag bit. This bit is set when CMPSTC is toggled, and the comparator C setting is enabled. This bit must be cleared by software.
CMPIFB	Comparator B Interrupt Flag bit. This bit is set when CMPSTB is toggled, and the comparator B setting is enabled. This bit must be cleared by software.
CMPIFA	Comparator A Interrupt Flag bit. This bit is set when CMPSTA is toggled, and the comparator A setting is enabled. This bit must be cleared by software.
CMPSTD	Comparator D Real-time Output. If comparator D is disabled, this bit is forced to low.
CMPSTC	Comparator C Real-time Output. If comparator C is disabled, this bit is forced to low.
CMPSTB	Comparator B Real-time Output. If comparator B is disabled, this bit is forced to low.
CMPSTA	Comparator A Real-time Output. If comparator A is disabled, this bit is forced to low.
FILEND	Comparator D Digital Filter Enable. The Filter is 16 SYSCLK.
FILENC	Comparator C Digital Filter Enable. The Filter is 16 SYSCLK.
FILENB	Comparator B Digital Filter Enable. The Filter is 16 SYSCLK.
FILENA	Comparator A Digital Filter Enable. The Filter is 16 SYSCLK.

DACCFG (0xA03Ch) Analog Comparator Status Register R/W (0x00)

	7	6	5	4	3	2	1	0
RD	DACEN	VDDCCMPA	DACTEST	-	CMPHYSD	CMPHYSC	CMPHYSB	CMPHYSA
WR	DACEN	VDDCCMPA	DACTEST	-	CMPHYSD	CMPHYSC	CMPHYSB	CMPHYSA

DACEN	DAC Enable DACEN=1 turns on the DAC output buffer. DACEN=0 turns off the output buffer.
VDDCCMPA	Force CMPINA as VDDC. VDDCCMPA = 1, CMPINA is connected to VDDC. This is for testing purposes only. By connecting VDDC to CMPINA and GPIO ANIO switch, VDDC is exposed on GPIO pin so testing and trimming of VDDC can be done.
DACTEST	DAC/ADC Test Mode DACTEST=1 connect DACOUT to ADC's CHB input internally. This needs software to perform DAC output and ADC conversion.
CMPHYSD	Comparator D Hysteresis Disable CMPHYSD = 1 disables the hysteresis of Comparator D. CMPHYSD = 0 enables the hysteresis (typical 10mV) of Comparator D.
CMPHYSC	Comparator C Hysteresis Disable CMPHYSC = 1 disables the hysteresis of Comparator C. CMPHYSC = 0 enables the hysteresis (typical 10mV) of Comparator C.
CMPHYSB	Comparator B Hysteresis Disable CMPHYSB = 1 disables the hysteresis of Comparator B. CMPHYSB = 0 enables the hysteresis (typical 10mV) of Comparator B.
CMPHYSA	Comparator A Hysteresis Disable CMPHYSA = 1 disables the hysteresis of Comparator A. CMPHYSA = 0 enables the hysteresis (typical 10mV) of Comparator A.

IS32CS8975

18. Touch Key Control III

TK3 is an enhanced TK2 implementation with differential dual slope operations. The capacitance to count conversion goes through two phase of capacitor charge transfer. Phase one is to charge and the second phase is to discharge using two thresholds equally spaced from $\frac{1}{2}$ VDDC. Each charge transfer is obtained by subtraction of charge on internal reference capacitance and key capacitance. The difference of charge and discharge counts is used to determine the key capacitance change in the ratio of internal capacitance. Better noise immunity from power, ground and common-mode noise is achieved by dual slope operation. Better S/N can also be achieved since only charge value difference is used for count transfer, and the internal capacitance exhibits better temperature and environmental immunity to make the conversion result less sensitive to these changes.

CREF, the integration capacitor of the charge transfer, is connected to P00 through ANIO multiplexer and CKEY is connected to other GPIO through multiplexer. A replica signal of CKEY is provided through a buffer and routed out as SHIELD through GPIO. The shield signal can be used to cancel mutual capacitance effect from neighboring signal trace of the detected key and provides better noise immunity against moisture or water.

To detect a key trigger status, the duty count value TKLDT[15-0] or TKHDT[15-0] can be processed by software and compared with the average non-pressing key duty count. The hardware can also be configured to auto repeat accumulations of the duty cycle count to filter the sporadic noise effect. Since the comparator output should be a random duty with an average equivalent to the capacitance ratio, for low frequency noise rejection, the hardware can be set to reject a continuous high or low comparator output that exceeds long durations. For high frequency noise rejection, the hardware includes a pseudo-random sequence that randomizes the charge and discharge timing sequences. A slow moving average of the duty count value is stored in TKBASE[15-0] and software can use this for baseline calculation to auto-compensate environment change.

Issuing a START command in the TK3CFGD register starts a conversion sequence that accumulates the comparator output into count value. The count value and the total number of the cycle of the sequence can then be calculated to obtain the capacitance of the key. The timing diagram of the TK3 in normal operation is shown in the following diagram. CREF is first equalized to VREFX that is in the adjacent range of VREF. When a START command is issued, the first few edges of the comparator output is ignored to avoid any noise caused by the VREFX switching. And then the compactor output is accumulated into DTYL and DTYH registers. A sequence can consist of several conversion cycles depending on the RPT setting, and DTYL and DTYH maintain accumulation to obtain higher resolutions. After the sequence is completed, CREF is also connected to VREFX to stay ready for the next sequence to start.

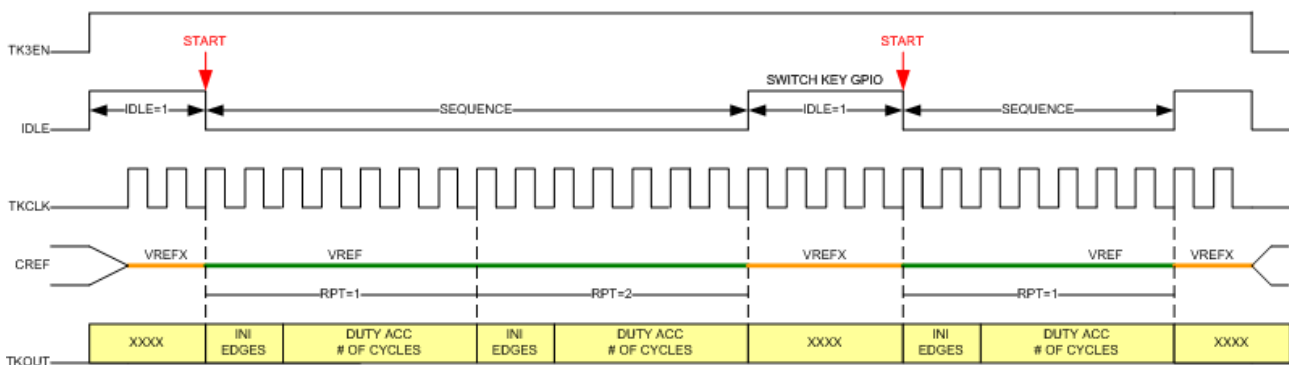

Figure 18-1 TK3 signals timing diagram

TK3 can be set into low power auto detect mode by setting AUTO bit in TK3CFGD. In this mode, an ultra-low power comparator is used and the clock for TK3 should be set to SOSC/2 (64KHz). This mode can be used specifically for touch key wakeup during the MCU sleep mode. The total power consumption of TK3 in this mode is less than 5uA. A threshold register can be set to determine the auto detect threshold either in absolute value or relative value versus the slow-moving baseline value. When the duty count value exceeds the threshold value, a wakeup event and an interrupt are generated. The timing diagram for auto mode detection and entering SLEEP mode is shown in the following diagram. Note the actual start of the sequence is delayed by AUTO START DELAY setting. This allows the internal VDDC to stabilize from switching normal mode to sleep mode power supply regulators.

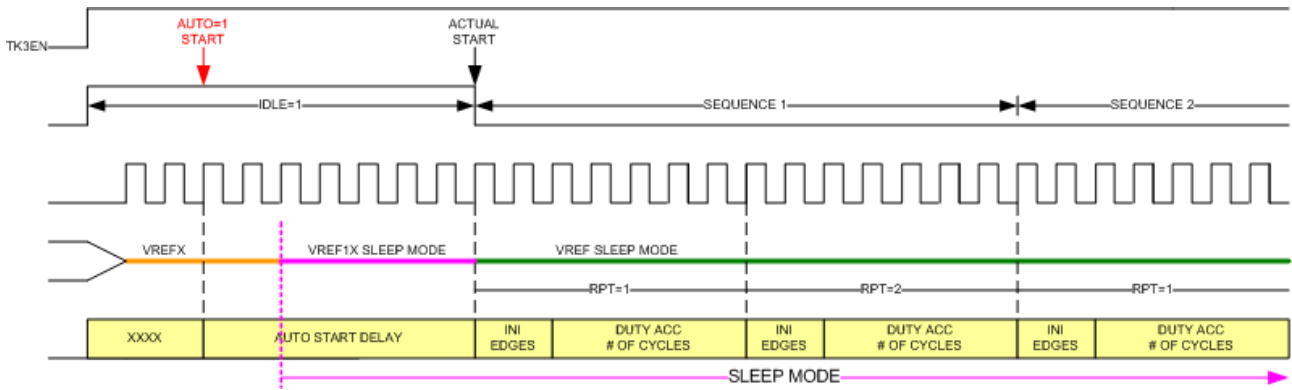

Figure 18-2 Timing diagram of Auto Detection in Sleep mode

TK3CFG A (0xA018h) TK3 Configuration Register A R/W (0x00)

	7	6	5	4	3	2	1	0
RD	TK3EN	TKCS[2-0]			SHIELDEN	TKIEN	TKLPM	AUTO
WR	TK3EN	TKCS[2-0]			SHIELDEN	TKIEN	TKLPM	AUTO

- TK3EN
TK3 Enable.
Set TK3EN=0 to disable the TK3 circuits and clear all states.
Set TK3EN=1 for TK3 normal operations.
- TKCS[2-0]
TK3 Clock Select
TKCS[2-0]=000 SYCLK/2
TKCS[2-0]=001 SYCLK/4
TKCS[2-0]=010 SYCLK/6
TKCS[2-0]=011 SYCLK/8
TKCS[2-0]=100 SYCLK/10
TKCS[2-0]=101 SYCLK/16
TKCS[2-0]=110 SYCLK/32
TKCS[2-0]=111 SOSC/2
SOSC/2 should be used for sleep mode auto wakeup. Typical SOSC/2 is 64KHz.
- SHIELDEN
Shield Output Buffer Enable
SHIELDEN=1 enables the shield signal buffer. The buffer consumes about 200uA when enabled.
- TKIEN
TK3 Interrupt Enable
TKIEN=1 enables the TK3 interrupt. TK3 interrupt is generated when a counting sequence is completed (including the repeat count if RPT[1-0] is not 00). Interrupt and wakeup events are also generated when TKIEN=1 and AUTO=1 after auto detection threshold is reached.
- TKLPM
TK3 Low Power Mode
Set TKLPM=0 for normal mode operations.
Set TKLPM=1 to put the comparator into ultra low power mode and should be used in auto wakeup power saving mode. In this mode, TKCLK should use SOSC/2 (64KHz) slow clock.
- AUTO
Auto Wake Up Mode
AUTO=1 enables auto detect mode. In auto mode, the current duty count register value is compared with baseline plus threshold (either absolute or relative). If the duty count value is higher, an interrupt and wakeup event is generated.
Set AUTO=0 to enable normal detect mode. In normal mode, writing START with "1" initiates a conversion sequence, and an interrupt is generated when the duty count is reached.

TK3CFG B (0xA019h) TK3 Configuration Register B R/W (0x00)

	7	6	5	4	3	2	1	0
RD	RPT[1-0]		INI[1-0]		ASTDLY[1-0]		LFNF[1-0]	
WR	RPT[1-0]		INI[1-0]		ASTDLY[1-0]		LFNF[1-0]	

- RPT[1-0] Repeat Sequence Count
00 = No Repeat
01 = 4 times
10 = 8 times
11 = 16 times
- INI[1-0] Initial Settling Delay
INI[1-0] defines the number of TKCLK period for initial settling of CREF. The delay is set to (INI[1-0] + 1) * 4 * TKCLK.
- ASTDLY[1-0] Auto Mode Start Delay
STDLY[1-0] inserts an inter-sequence idle time of (ASTDLY[1-0]+1) * 256 TKCLK at each sequence start. This delay allows the stabilization time of VREFX from normal mode to sleep mode.
- LFNF[1-0] Low Frequency Noise Filter Setting
Set 00 to disable LFNF.
Noise injection longer than LFNF[1-0]*8 time is ignored.
Please note in the presence of such noise, the cycle count still continues. The end result is that the sum of DUTYL and DUTYH will not be equal to cycle count.

TK3CFG (0xA01Ah) TK3 Configuration Registers C R/W (0x00)

	7	6	5	4	3	2	1	0
RD	SLOW[1-0]		CYCLE[2-0]			BASEINI	THDSEL	AUTOLFEN
WR	SLOW[1-0]		CYCLE[2-0]			BASEINI	THDSEL	AUTOLFEN

- SLOW[1-0] Baseline Slow Moving Average setting
00 = 32 average
01 = 64 average
10 = 128 average
11 = 256 average
The duty value is averaged by SLOW[1-0] conversion and updated to BASELINE register through moving average.
- CYCLE[2-0] Cycle Count of each conversion sequence
000 = 1024
001 = 2048
010 = 4096
011 = 8192
100 = 12288
101 = 16384
110 = 32768
111 = 65536
The cycle count is each sequence cycle count. And it is repeated if RPT is not 0. Please note the conversion always ends with the defined cycle count.
- BASEINI Baseline Initial Value
If BASEINI=1, then the first DTYL count after entering auto mode is loaded to BASELINE register as its initial value to start moving average.
If BASEINI=0, then the value written in BASELINE before entering auto mode is used as the initial value to start moving average.
- THDSEL Threshold Value Setting
When THDSEL=0, TKTHD[15-0] is used as the threshold to compare with DTYL to generate the interrupt and wakeup.
When THDSEL=1, TKTHD[15-0] + TKBASE[15-0] is used as the threshold.
- AUTOLFEN Low Frequency Noise Filtering in Auto mode
If AUTOLFEN=0, low frequency noise filtering in Auto mode is disabled.
If AUTOLFEN=1, low frequency noise filtering in auto mode is enabled.
The low noise filtering status flag is still valid regardless of AUTOLFEN setting. Software can determine whether to discard the current conversion result by checking LFNF flag.

TK3CFGD (0xA01Bh) TK3 Configuration Registers D R/W (0x00)

	7	6	5	4	3	2	1	0
RD	CCHG[2-0]			ASTDLYEN	PSRDEN	LFNF	TKIF	BUSY
WR	CCHG[2-0]			ASTDLYEN	PSRDEN	LFNF	TKIF	START

CCHG[2-0]	Charge Capacitance Select 000 = 10pF 001 = 20pF 010 = 30pF 011 = 40pF 100 = 50pF 101 = 60pF 110 = 70pF 111 = 80pF
ASTDLYEN	Auto Start Delay Enable Set ASTDLYEN=1 to enable ASTDLY[1-0] delay start for auto mode. Set ASTDLYEN=0 to disable ASTDLY[1-0] delay.
PSRDEN	Pseudo Random Sequence Enable Set PSRDEN=1 to enable the random sequence in conversion. Set PSRDEN=0 to disable the random sequence in conversion.
LFNF	Low Frequency Noise Detection Flag LFNF is set by hardware if a Low Frequency Noise is detected during the present conversion. LFNF needs to be cleared to "0" by software
TKIF	TK3 Interrupt Flag TKIF is set by hardware when a TK3 interrupt occurred by either conversion sequence completed or a valid detection in auto mode. TKIF needs to be cleared to "0" by software.
START	Start Conversion Writing "1" into START initiates the conversion sequence. It is cleared by hardware when conversion is complete. Writing AUTO "1" also starts the conversion in auto mode.
BUSY	Conversion Status BUSY is set to 1 by hardware indicating the conversion sequences are still running.

TK3HDTYL (0xA01Ch) TK3 High Duty Count Register L RO (0x00)

	7	6	5	4	3	2	1	0
RD	TK3HDTY[7-0]							
WR	-							

TK3HDTYH(0xA01Dh) TK3 High Duty Count Register H RO (0x00)

	7	6	5	4	3	2	1	0
RD	TK3HDTY[15-8]							
WR	-							

TK3LDTYL (0xA01Eh) TK3 Low Duty Count Register L RO (0x00)

	7	6	5	4	3	2	1	0
RD	TK3LDTY[7-0]							
WR	-							

TK3LDTYH(0xA01Fh) TK3 Low Duty Count Register H RO (0x00)

	7	6	5	4	3	2	1	0
RD	TK3LDTY[15-8]							
WR	-							

IS32CS8975

TK3BASEL (0xA028h) TK3 Baseline Register L R/W (0x00)

	7	6	5	4	3	2	1	0
RD	TK3BASE[7-0]							
WR	TK3BASE[7-0]							

TK3BASEH (0xA029h) TK3 Baseline Register H R/W (0x00)

	7	6	5	4	3	2	1	0
RD	TK3BASE[15-8]							
WR	TK3BASE[15-8]							

TK3THDL (0xA02Ah) TK3 Threshold Register L R/W (0x00)

	7	6	5	4	3	2	1	0
RD	TK3THD[7-0]							
WR	TK3THD[7-0]							

TK3THDH (0xA02Bh) TK3 Threshold Register H R/W (0x00)

	7	6	5	4	3	2	1	0
RD	TK3THD[15-8]							
WR	TK3THD[15-8]							

TK3PUD (0xA02Ch) TK3 DC Pull-Up/Pull-Down Control Register H R/W (0x00)

	7	6	5	4	3	2	1	0
RD	PUDIEN	PUDREN	-	-	PUD[3-0]			
WR	PUIDEN	PUDREN	-	-	PUD[3-0]			

TK3PUD is to configure a constant DC pull-up/pull-down on CREF to allow high capacitance touch-key detection. A DC pull-up/pull-down can compensate for the equivalent resistance caused by a high capacitance key. Connecting a switching current source or resistor can thus maintain touch key detection sensitivity.

PUDIEN	Pull-up/Pull-down DC Current Enable
PUDREN	Pull-up/Pull-down DC Resistor Enable
PUD[3-0]	Pull-up/Pull-down Selection
	For DC current, PUD[3-0] enables 8uA/4uA/2uA/1uA current source.
	For resistor, PUD[3-0] enables 5K/10K/20K/40K resistor.

19. GPIO Multi-Function Select and Pin Interrupt

Each IO pin has a configurable IO buffer that can meet various interface requirements. The GPIO pins can be configured as external interrupt input pins or for wakeup purposes. Each port has edge detection logic and latch for rising and falling edge detections. During hardware reset and after, the IO buffer is put in high impedance state with all drivers disabled.

IOCFG0xx(0xA100h – 0xA10Fh) IO Buffer Output Configuration Registers R/W (0x00) (xx = 00~07, 10~17)

	7	6	5	4	3	2	1	0
RD	-	PDRVEN	NDRVEN	OPOL	ANEN2	ANEN1	PUEN	PDEN
WR	-	PDRVEN	NDRVEN	OPOL	ANEN2	ANEN1	PUEN	PDEN

PDRVEN	PMOS driver output enable. Set this bit to enable the PMOS of the output driver. DISABLE is the default setting.
NDRVEN	NMOS driver output enable. Set this bit to enable the NMOS of the output driver. DISABLE is the default setting.
OPOL	Polarity Output Control Buffer data Output polarity control.
ANEN1	Analog MUX 1 enable control. Set this bit to connect the pin to the internal analog peripheral. DISABLE is the default setting.
ANEN2	Analog MUX 2 enable control. Set this bit to connect the pin to the internal analog peripheral. DISABLE is the default setting.
PUEN	Pull up resistor control. Set this bit to enable pull-up resistor connection to the pin. The pull-up resistor is approximately 6K Ohm. DISABLE is the default setting.
PDEN	Pull down resistor control. Set this bit to enable pull-down resistor connection to the pin. The pull-down resistor is approximately 6K Ohm. DISABLE is the default setting.

IOCFG1 xx(0xA110h – 0xA11Fh) IO Buffer Input Configuration Registers R/W (0x00) (xx = 00~07, 10~17)

	7	6	5	4	3	2	1	0
RD	PI1EN	PI0EN	RIF	FIF	INEN	IPOL	DSTAT	INSTAT
WR	PI1EN	PI0EN	RIEN	FIEN	INEN	IPOL	DBN[1-0]	

PI1EN	Pin Interrupt 1 Enable
PI0EN	Pin Interrupt 0 Enable
RIEN	Rising Edge Pin Interrupt Enable
RIF	Rising Edge Pin Interrupt Flag RIF is set to 1 by hardware after either a PI1 or PI0 rising edge interrupt has occurred. RIF must be cleared by software writing RIEN with "0". RIEN needs to be enabled if the next rising edge interrupt is required.
FIEN	Falling Edge Pin Interrupt Enable
FIF	Falling Edge Pin Interrupt Flag FIF is set to 1 by hardware after either a PI1 or PI0 falling edge interrupt has occurred. FIF must be cleared by software writing FIEN with "0". FIEN needs to be enabled if the next falling edge interrupt is required.
INEN	Input Buffer Enable Set INEN=1 to enable the input buffer. Set INEN=0 to disable the input buffer. In the disabled state, the output of input buffer is logic 0. If input is floating or not solid 0 and 1 voltage level, DC current may flow in the input buffer. Disabling input buffer can remove DC leakage of input buffer due to this reason.
IPOL	Input Polarity IPOL=1 reverses the input logic. IPOL=0 for normal logic polarity.
DBNST	Real Time Status after De-bounce. DBNST is read only. Please note the de-bounced input is used for generating interrupt, as well as all other multi-function inputs including PORT registers. The non-debounced input can only be read through INSTAT bit.
INSTAT	Real Time Status of Input Buffer. INSTAT is read only.
DBN[1-0]	De-Bounce Time Setting 00 – OFF

IS32CS8975

- 01 – 4 SOSC32KHz (125usec)
- 10 – 16 SOSC32KHz (500usec)
- 11 – 64 SOSC32KHz (2msec)

MFCFG_{xx} (0xA120 – 0x A12Fh) Port Multi-Function Configuration Registers R/W (0x00) (xx = 00~07, 10~17)

	7	6	5	4	3	2	1	0
RD	MFCFG[7-0]							
WR	MFCFG[7-0]							

Please see PINOUT section for description of each port multi-function selection.

20. Information Block IFB

There are two IFB blocks and each one contains 512x16 bit information. The address 0x000h to 0x03Fh in first IFB is used to store manufacturer information. Address 0x040 is for boot code wait time, and 0x041 to 0x043 are used for boot code. The first IFB can be erased only in Writer Mode and can be written using Flash Controller for addresses beyond 0x40. This is to protect any alteration of the manufacturer and calibration data. The 2nd IFB is open for erase/write for user access. The following table shows the contents of the first IFB for the manufacturer data. Please note that these are in lower LSB bytes. The upper MSB byte contains its corresponding ECC code.

ADDRESS	TYPE	DESCRIPTION
00 – 01	M	IFB Version
02 – 07	M	Product Name
08 - 09	M	Package and Product Code
0A – 0B	M	Product Version and Revision
0C	M	Flash Memory Size
0D	M	SRAM Size
0E – 0F	M	Customer Specific Code
10	M	CP1 Information
11	M	CP2 Information
12	M	CP3 Version
13	M	CP3 BIN
14	M	FT Version
15	M	FT BIN
16 - 1B	M	Last Test Date
1C – 1D	M	Boot Code Version
1E	M	Boot Code Segment
1F	M	Checksum for 0x00 – 0x1E
20	M	REGTRM value for 1.5V
21	M	IOSC ITRM value for 16MHz @5V
22	M	IOSC VTRM value for 16MHz @5V
23	M	LVDTHD value for detection of 4.0V
24	M	LVDTHD value for detection of 3.0V
25	M	IOSC ITRM value for 32MHz @5V
26	M	IOSC VTRM value for 32MHz @5V
27	M	Reserved
28	M	Reserved
29	M	Reserved
2A	M	Reserved
2B – 2C	M	Temperature Offset LSB/MSB
2D	M	Temperature Coefficient
2E – 2F	M	Internal Reference LSB/MSB
30	M	SOSC 128KHz Trim
31 – 33	M	Reserved
34	M	Timer 0 High TRIM *
35	M	Timer 0 Low TRIM *

ADDRESS	TYPE	DESCRIPTION
36 – 38	M	Reserved
39	M	Checksum for 0x20 – 0x39
3A – 3F	M	Retention Value
40	M/U	<p>Boot Code Wait Time. Boot code uses this byte to decide the ISP wait-time. This wait-time is necessary for stable ISP access. After the user program is downloaded, the wait time can be reduced to minimize power-on time.</p> <p>Each “1” in bit[0] or bit [1] constitutes 1 second, each “1” in bit [2] or bit [3] constitutes 2 second and each “1” in bit [6] or bit [7] are for I2CSCL1 and I2CSCL2 check. For example, 0b10000111 refers to a 4 second wait time and check of I2CSCL2 pin status. If I2CSCL2 is low, then the wait time is 6 second regardless of bit [3-0] setting. The maximum wait time is 6 second, and minimum wait time is 0 second.</p>
41 – 43	M	Reserved
44 - 1FF	U	User One-Time Programmable Space

Table 20-1 Information Block (IFB)

IS32CS8975

21. Writer Mode

Writer Mode (WM) is used by the manufacturers or by users to program the flash (including IFB) through a dedicated hardware (Writer or Gang Writer). There are several pins involved for WM as shown in the following table. These pins are also used for test modes such as scan test, MBIST, and trim test.

PIN	IO	Description	Function
P00	O	Serial data out	SDO
P01	I	Serial clock input	SCK
P02	O	Flash TBIT signal output	TBIT
P03	I	Serial data in and sequence in	SEQIN
P04	I	Serial port enable, low active	SCE
VDD	I	Power supply for DUT and Disable P03 Output when VDD > 7.0V	VDD
VSS	I	Ground supply for DUT	VSS

Table 21-1 Timing diagram for Writer Mode access

To enter into WM, a predefined sequence must be present at SDI (SEQIN) pin within 10 second of power-on or RSTN reset. The following timing diagram shows the waveform relationship.

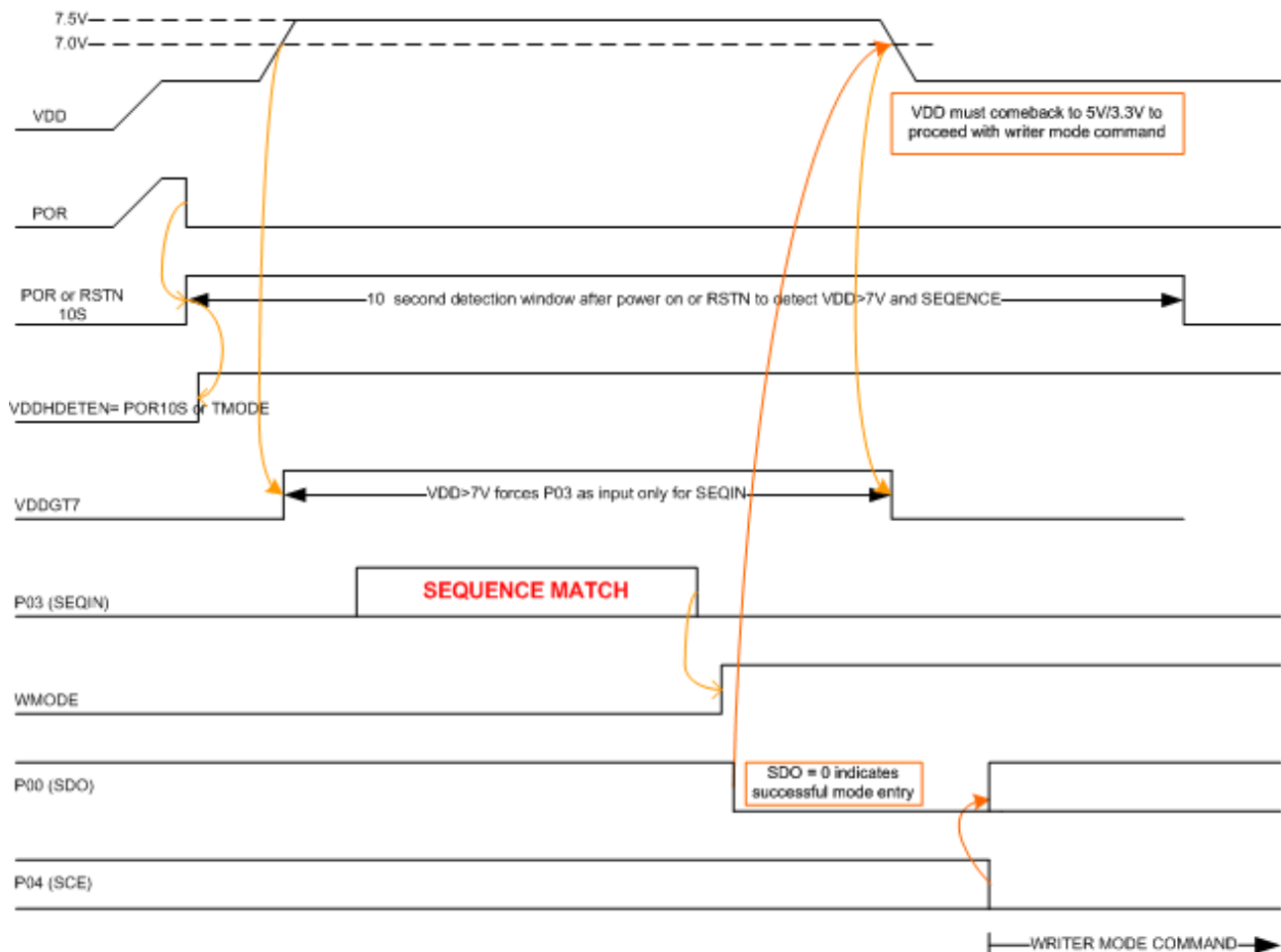

Figure 21-1 Timing diagram for Writer Mode access

1. After power-on reset or RSTN reset, a 10-second window is open for SEQIN buffer and detection comparator for VDD > 7V.
2. If VDD > 7V is detected, it forces P03 to tri-state output and allows SEQIN buffer to detect the entry sequence. If P03 is not configured as an output, then VDD > 7V is not necessary (but always recommended).
3. If a correct sequence is detected, the WMODE internal signal is asserted, and this also enables SDO pull-down

to low to acknowledge Writer hardware for a successful entry.

4. Writer hardware upon receiving acknowledgement should bring down VDD to normal value (either 5V or 3.3V) to proceed with writer mode commands.

5. Writer hardware should have all writer mode related pins connected 10K pull-up resistor to its supply voltage (either 5V or 3.3V).

Once successful mode entry is completed, the protection must first be unlocked to fully utilize the writer mode commands. Before unlocking, only full memory erase command is supported. Unlock is accomplished by READ AND VERIFY Main Memory command with correct lock key (8-byte) of the key addresses. The following lists the writer mode commands. Below three commands in red color are available in locked state.

ERASEMM - ERASE Main Memory

ERASEMMIFB - ERASE Main Memory and IFB

READVERIFYMM - READ AND VERIFY Main Memory (8-Byte)

WRTEBYTEMM - WRITE BYTE Main Memory

READBYTEMM - READ BYTE Main Memory

WRITEBYTEIFB - WRITE BYTE IFB

READBYTEIFB - READ BYTE IFB

FCWRITE - Fast Continuous WRITE

FCREAD - Fast Continuous READ

The default state of the device is with writer mode locked. Only ERASEMM and ERASEMMIFB, and READVERIFYMM commands can be executed. It can be unlocked by READVERIFYMM the range of 0x2FF8 to 0x2FFF. These locations contain an 8-byte security key that user can set to secure the e-Flash contents. The probability of guessing the key is 1 in $2^{64} = 1.8E19$. Since each trial of READVERIFY takes 10usec, it takes about 6E6 years to exhaust the combinations. If the key is unknown, the user can choose to issue the ERASEMM command and fully erase the entire contents (including the key). Once fully erased, all data in the flash is 0xFF, and it can be successfully unlocked by READVERIFYMM with 8-bytes of 0xFF. Users must not erase the information in IFB and should not modify the manufacturer data. Any violation of this results in the void of manufacturer warranty.

22. Boot Code and In-System Programming

After production testing of the packaged devices, the manufacturer writes the manufacturer information and calibration data in the IFB. At the last stage, it needs to have a fixed boot-code in the main memory residing from 0x3000 to 0x3FFF. The boot code is executed after any reset. The boot code first reads IFB's wait time setting and scans the I²C slave for any In-System-Programming request during the wait time duration. If any valid request occurs during the scan, the boot-code proceeds to follow the request and perform the programming from the host. Otherwise, the boot code jumps to 0x0000 when the wait time expires. The default available ISP commands are

UNLOCK

DEVICE NAME

BOOTC VERSION

READ AND VERIFY Main Memory (8-Byte)

ERASE Main Memory excluding Boot Code

ERASE SECTOR Main Memory

WRITE BYTE Main Memory

SET ADDRESS

CONTINUOUS WRITE

CONTINUOUS READ

READ BYTE IFB

WRITE BYTE IFB

Like writer mode, ISP is in lock state at default. No command is accepted under the lock state. To unlock the ISP, an 8-byte READ and VERIFY of 0x2FF8 to 0x2FFF must be successfully executed. Hence default ISP boot program provides similar code security as the Writer mode.

IS32CS8975

23. Electrical Specifications

23.1 Absolute Maximum Ratings

SYMBOL	PARAMETER	RATING	UNIT	NOTE
VDD	Supply Voltage	5.5	V	
TA	Ambient Operating Temperature	-40 – 125	°C	
TSTG	Storage Temperature	-65 – 150	°C	

Supply voltage, V _{CC}	-0.3V ~ +6.0V
Voltage at any input pin	-0.3V ~ V _{CC} +0.3V
Maximum junction temperature, T _{JMAX}	+150°C
Storage temperature range, T _{STG}	-65°C ~ +150°C
Operating temperature range, T _A =T _J	-40°C ~ +125°C
Junction Package thermal resistance, junction to ambient (4-layer standard test PCB based on JESD 51-2A), θ _{JA}	50.2°C/W(TSSOP-16) 53.5°C/W(WQFN-16)
ESD (HBM)	±2kV
ESD (CDM)	±750V

Note 3: Stresses beyond those listed under “Absolute Maximum Ratings” may cause permanent damage to the device. These are stress ratings only and functional operation of the device at these or any other condition beyond those indicated in the operational sections of the specifications is not implied. Exposure to absolute maximum rating conditions for extended periods may affect device reliability.

23.2 Recommended Operating Condition

SYMBOL	PARAMETER	RATING	UNIT	NOTE
VDD	Supply Voltage for IO and 1.5V regulator	2.35 – 5.5	V	
TA	Ambient Operating Temperature	-40 – 125	°C	

23.3 DC Electrical Characteristics (VDD = 2.35V to 5.5V TA=-40°C to 125°C)

SYMBOL	PARAMETER	MIN	TYP	MAX	UNIT	NOTE
Power Supply Current						
IDD Normal	Total IDD through VDD at 16MHz Peripherals off	-	5	-	mA	
IDD Normal	Total IDD through VDD at 1MHz Peripherals off	-	1.0	-	mA	
IDD versus Frequency	IDD Core Current versus Frequency	-	150	-	uA/ MHz	
IDD, Stop	IDD, stop mode	-	150	-	µA	Main regulator on
IDD, Sleep	IDD, sleep mode, 25°C	-	1.5	5	µA	Main regulator off
	IDD, sleep mode, 85°C	-	4	10	µA	Main regulator off
	IDD, sleep mode, 125°C	-	15	40	µA	Main regulator off
RSTN Reset						
VIHRS	Input High Voltage, reference to VDD	-0.8	-	-	V	
VILRS	Input Low Voltage	-	-	0.8	V	
VRSHYS	RSTN Hysteresis	-	1.2	-	V	
GPIO DC Characteristics						
VOH,4.5V	Output High Voltage 1 mA	-	-0.2	-0.5	V	Reference to VDD

SYMBOL	PARAMETER	MIN	TYP	MAX	UNIT	NOTE
VOH,4.5V	Output High Voltage 2 mA	-	-0.3	-0.7	V	Reference to VDD
VOL,4.5V	Output Low Voltage 4 mA	-	0.2	0.4	V	Reference to VSS
VOL,4.5V	Output Low Voltage 8 mA	-	0.3	0.5	V	Reference to VSS
VOH,3.0V	Output High Voltage 1 mA	-	-0.3	-0.6	V	Reference to VDD
VOH,3.0V	Output High Voltage 2 mA	-	-0.4	-0.8	V	Reference to VDD
VOL,3.0V	Output Low Voltage 4 mA	-	0.2	0.4	V	Reference to VSS
VOL,3.0V	Output Low Voltage 8 mA	-	0.3	0.6	V	Reference to VSS
I _{IOT}	Total IO Sink and Source Current	-80	-	80	mA	
V _{IH}	Input High Voltage	$\frac{3}{4}V_{DD}$	-	-	V	
V _{IL}	Input Low Voltage	-	-	$\frac{1}{4}V_{DD}$	V	
V _{IHYS}	Input Hysteresis	100	300	600	mV	
R _{PU}	Equivalent Pull-Up Resistance	-	25K	-	Ohm	
R _{PU,RSTN}	RSTN Pull-Up Resistance	-	5K	-	Ohm	
R _{PD}	Equivalent Pull-Down Resistance	-	25K	-	Ohm	
REQAN1	Equivalent ANIO Switch Resistance, 3.3V	-	800	-	Ohm	ANIO1 Switch
	Equivalent ANIO Switch Resistance, 5V	-	500	-	Ohm	ANIO1 Switch
REQAN2	Equivalent ANIO Switch Resistance, 3.3V	-	4K	-	Ohm	ANIO2 Switch
	Equivalent ANIO Switch Resistance, 5V	-	2.5K	-	Ohm	ANIO2 Switch
VDDC Characteristics						
V _{DDCN}	Normal Core Voltage 1.5V (Calibrated)	1.4	1.5	1.6	V	Normal Mode
V _{DDCS}	Sleep Core Voltage 1.5V	-	1.42	-	V	Sleep Mode
Low Supply (VDD) Voltage Detection						
V _{DET}	Detection Range	2.0	-	4.8	V	
V _{DETHYS}	Detection Hysteresis	-	100	-	mV	
ADC11 Characteristics						
ADCLIN	ADC Linearity, Center range	-2	0	+2	LSB	
	ADC Linearity, 0.2V to FS-0.2V	-4	0	+4	LSB	
ADCFQ	ADC Frequency	-	2	4	MHz	

23.4 AC Electrical Characteristics (VDD =2.3V to 5.5V TA=-40°C to 125°C)

SYMBOL	PARAMETER	MIN	TYP	MAX	UNIT	NOTE
System Clock and Reset						
FSYS	System Clock Frequency	-	16	33	MHz	
FIOSC	Crystal Oscillator Frequency	5	16	25	MHz	
TSIOSC	Stable Time for IOOSC after power up	2	-	-	msec	After VDD > 2.0V
Supply Timing						
TSUPRU	VDD Ramp Up time	1	-	50	msec	WST = 0 for 16MHz
TSUPRD	VDD Ramp Down Time	-	-	50	msec	
TPOR	Power On Reset Delay	-	5	-	msec	
IOOSC						

SYMBOL	PARAMETER	MIN	TYP	MAX	UNIT	NOTE
FIOSC	IOSC Calibrated 16MHz/32MHz	-1	0	+1	%	
	IOSC Startup Time	-	-	1	µsec	
	Temperature and VDD variation 85°C	-2	0	+2	%	
	Temperature and VDD variation 125°C	-3	0	+3	%	
SOSC						
FSOSC	Slow Oscillator frequency	-	128	-	KHz	
IO Timing						
TPD3 ++	Propagation Delay 3.3V No load	-	6	-	nsec	
TPD3 ++	Propagation Delay 3.3V 25pF load	-	15	-	nsec	
TPD3 ++	Propagation Delay 3.3V 50pF load	-	20	-	nsec	
TPD3 --	Propagation Delay 3.3V No load	-	5	-	nsec	
TPD3 --	Propagation Delay 3.3V 25pF load	-	12	-	nsec	
TPD3 --	Propagation Delay 3.3V 50pF load	-	15	-	nsec	
TPD5 ++	Propagation Delay 3.3V No load	-	5	-	nsec	
TPD5 ++	Propagation Delay 3.3V 25pF load	-	12	-	nsec	
TPD5 ++	Propagation Delay 3.3V 50pF load	-	16	-	nsec	
TPD5 --	Propagation Delay 3.3V No load	-	4	-	nsec	
TPD5 --	Propagation Delay 3.3V 25pF load	-	9	-	nsec	
TPD5 --	Propagation Delay 3.3V 50pF load	-	12	-	nsec	
Flash Memory Timing						
TEMAC	Embedded Flash Access Time	-	40	45	nsec	TWAIT must > TEMAC
TEMWR	Embedded Flash Write Time	-	20	25	µsec	
TEMSER	Embedded Flash Sector Erase Time	-	2	2.5	msec	
TEMMER	Embedded Flash Mass Erase Time	-	10	12	msec	

23.5 Classification Reflow Profiles

Pb-Free Process-Package Classification Temperatures

Package Thickness	Volume mm ³ <350	Volume mm ³ : 350-2000	Volume mm ³ >2000
<1.6 mm	260°C	260°C	260°C
1.6 mm-2.5 mm	260°C	250°C	245°C
>=2.5 mm	250°C	245°C	245°C

Profile Feature	Pb-Free Assembly
Ramp-Up Rate (TL to Tp)	3°C / second max.
Preheat – Temperature Min (T _{smin}) to Max (T _{smax})	150~200 °C
–To,e (t _{smin} to t _{smax})	60-120 seconds
Time maintained above – Temperature (TL)	217 °C
– Time (tL)	60-150 seconds
Peak package body temperature (Tp)(Note 2)	See package classification
Time within 5°C of specified classification Temperature (tp)	30 second min. (Note 3)

IS32CS8975

Profile Feature	Pb-Free Assembly
Ramp-Down Rate (Tp to TL)	6 °C / second max.
Time 25 °C to Peak Temperature	8 minutes max.
Number of applicable Temperature cycles	3 cycles max.

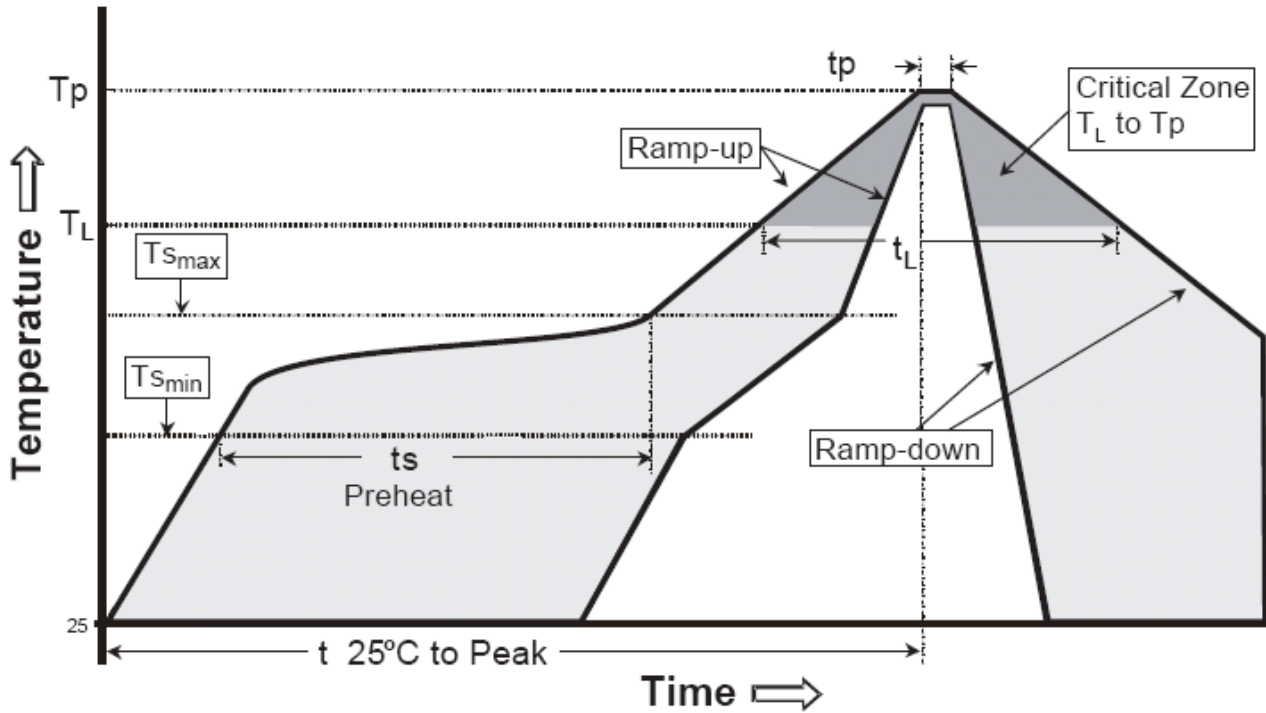

IS32CS8975

24. Packaging Outline

24.1 8-pin SOP

24.1.1 Recommended Land Pattern

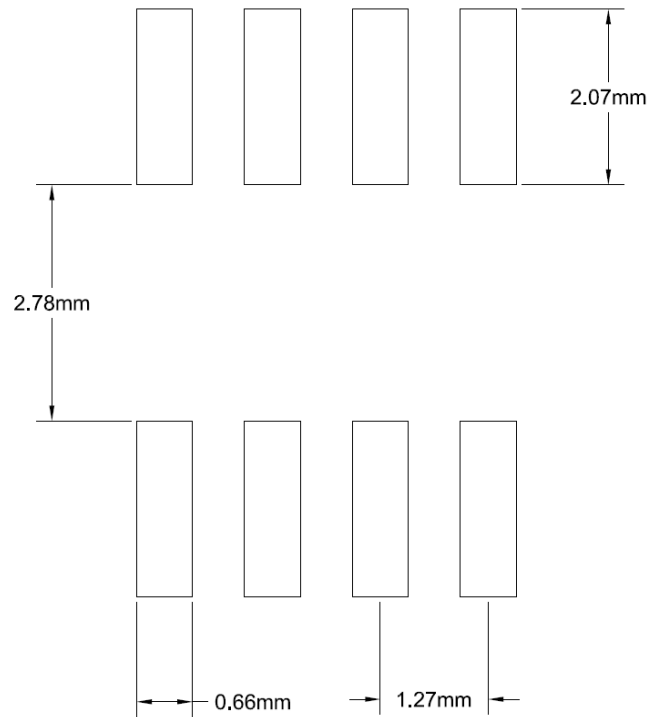

IS32CS8975

24.1.2POD

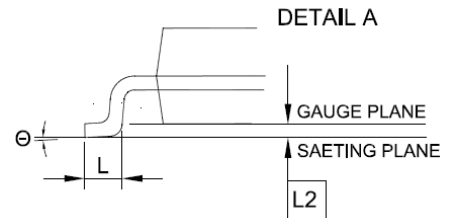
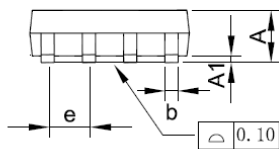
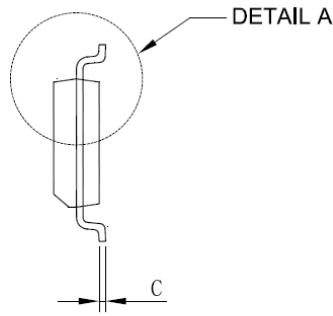
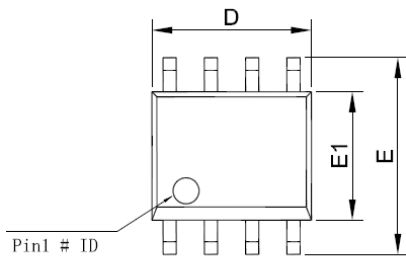

SYMBOL	MILLIMETER		
	MIN	NOM	MAX
A	-	-	1.75
A1	0.10	-	0.25
E1	3.80	3.90	4.00
E	5.80	6.00	6.20
D	4.80	4.90	5.00
b	0.31	-	0.51
e	1.27BSC		
L	0.40	-	1.27
L2	0.25BSC		
θ	0°	-	8°
C	0.10	-	0.25

NOTE:

1. CONTROLLING DIMENSION : MM
2. DIMENSION D DOES NOT INCLUDE MOLD FLASH, PROTRUSIONS OR GATE BURRS.
3. DIMENSION b DOES NOT INCLUDE DAMBAR PROTRUSION.
4. REFERENCE DOCUMENT : JEDEC MS-012
5. THE SHAPE OF BODY SHOWE DIFFERENT SHAPE AMONG DIFFERENT FACTORIES.

IS32CS8975

24.2 16-pin TSSOP

24.2.1 Recommended Land Pattern

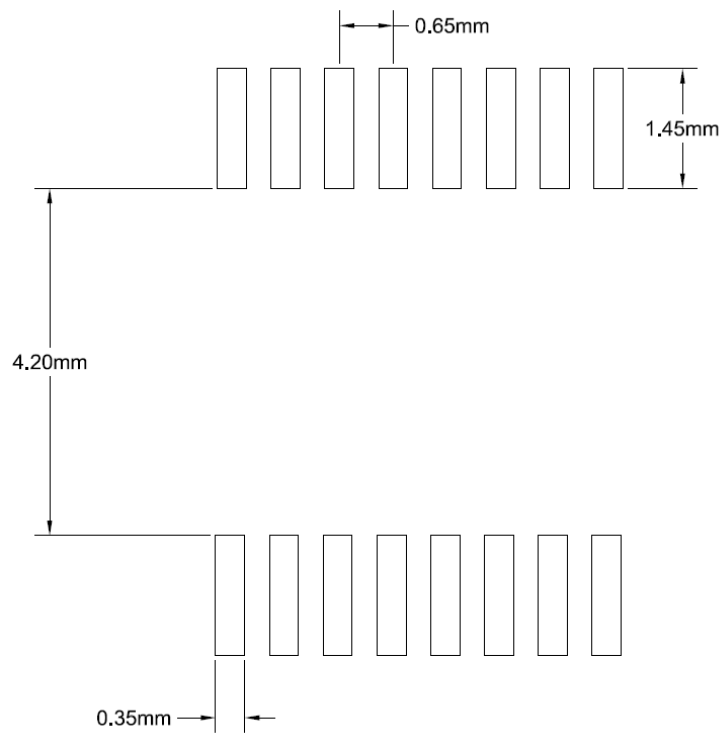

IS32CS8975

24.2.2POD

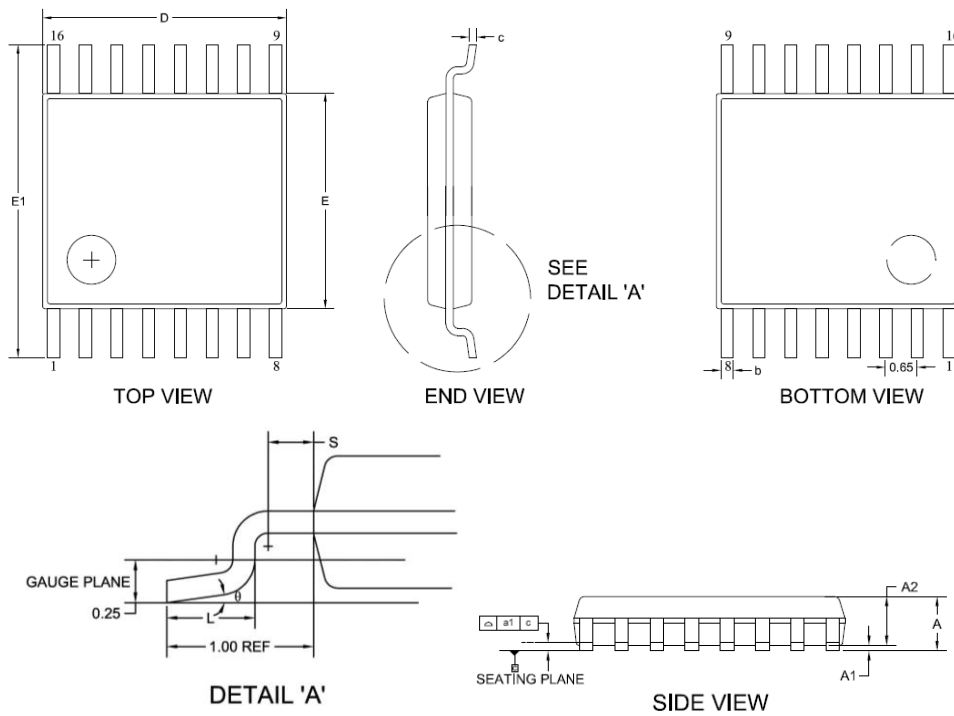

SYMBOL	MILLIMETER		
	MIN	NOM	MAX
A	—	—	1.20
A1	0.05	—	0.15
A2	0.80	1.00	1.05
D	4.90	5.00	5.10
E	4.30	4.40	4.50
E1	6.40BSC		
L	0.45	0.60	0.75
b	0.19	—	0.30
S	0.20	—	—
c	0.09	—	0.20
θ	0°	—	8°
a1	0.10		

NOTES:

1. CONTROLLING DIMENSION: MM
2. REFERENCE DOCUMENT: JEDEC MO-153

IS32CS8975

24.3 16-pin WQFN

24.3.1 Recommended Land Pattern

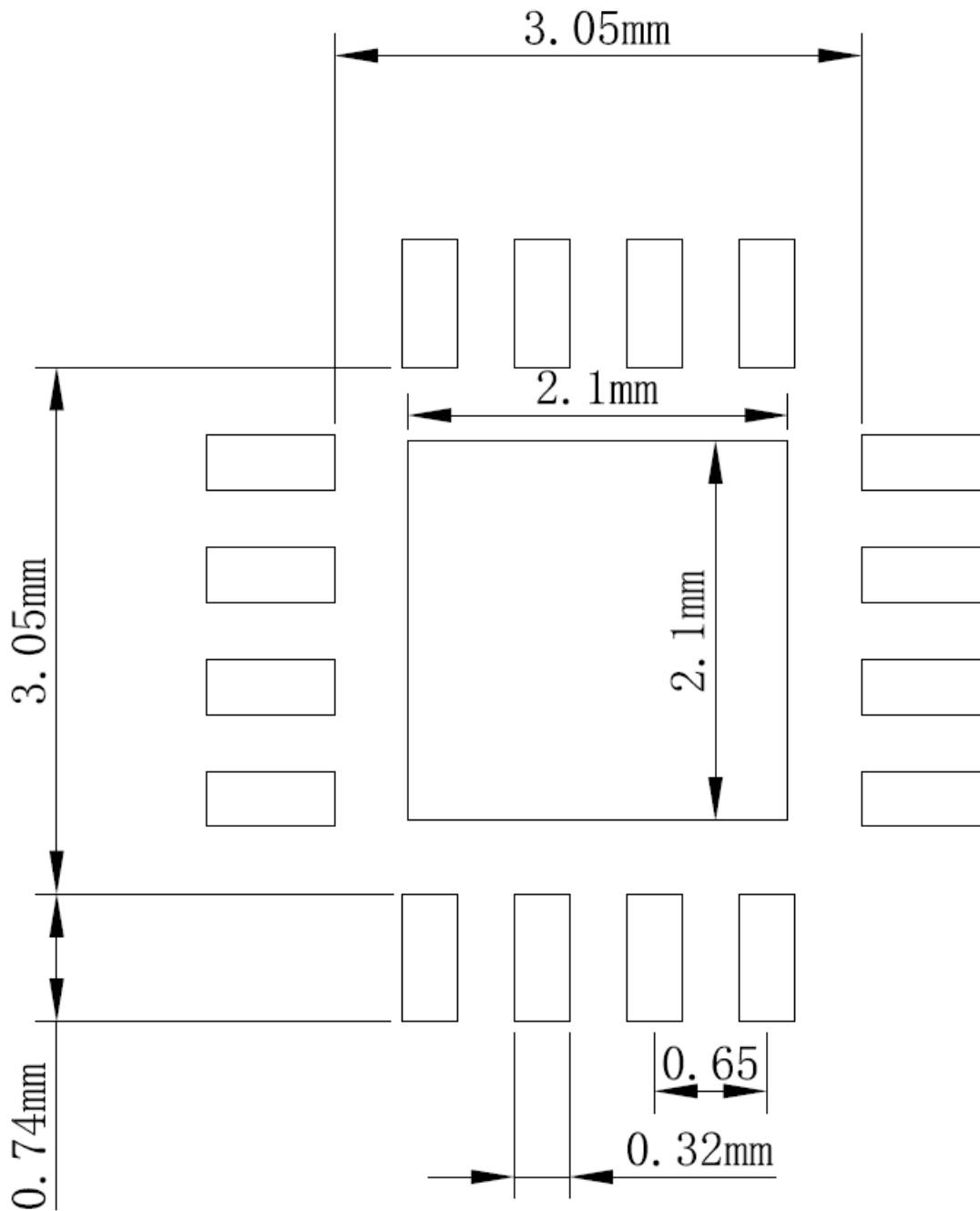

IS32CS8975

24.3.2POD

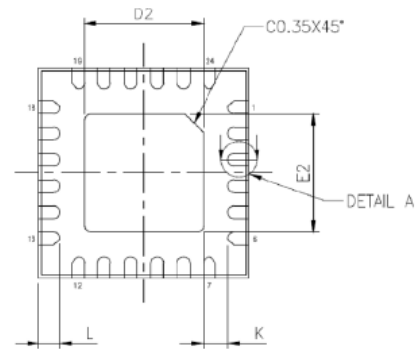
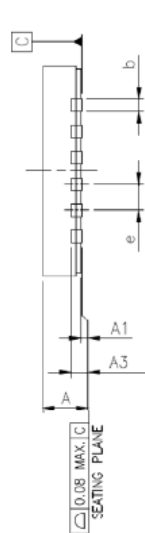
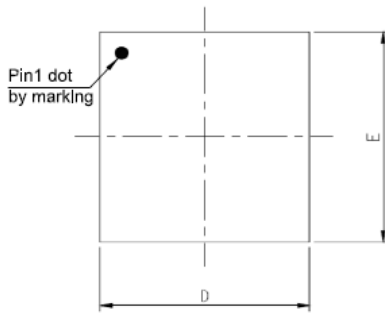

SYM BOL	MILLIMETER		
	MIN	NOM	MAX
A	0.70	0.75	0.80
A1	0.00	0.02	0.05
A3	0.203REF		
b	0.18	0.25	0.30
D	4.0BSC		
E	4.0BSC		
D2	2.65	2.70	2.75
E2	2.65	2.70	2.75
L	0.35	0.40	0.45
e	0.50BSC		
K	0.20	-	-

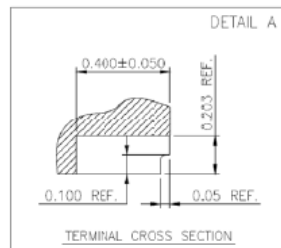

- NOTE:
1. CONTROLLING DIMENSION : MM
 2. REFERENCE DOCUMENT: JEDEC MO-220

IS32CS8975

25. Ordering Information

Temperature Range: -40°C to 125°C

Order Part No.	Package	QTY/Reel	Remark
IS32CS8975-GRLA3-TR	SOP-8, Lead-free	2500/Reel	
IS32CS8975-ZNLA3-TR	TSSOP-16, Lead-free	2500/Reel	
IS32CS8975-QWLA3-TR	WQFN-16, Lead-free	2500/Reel	

Copyright © 2020–2023 Lumissil Microsystems. All rights reserved. Lumissil Microsystems reserves the right to make changes to this specification and its products at any time without notice. Lumissil Microsystems assumes no liability arising out of the application or use of any information, products or services described herein. Customers are advised to obtain the latest version of this device specification before relying on any published information and before placing orders for products.

Lumissil Microsystems does not recommend the use of any of its products in life support applications where the failure or malfunction of the product can reasonably be expected to cause failure of the life support system or to significantly affect its safety or effectiveness. Products are not authorized for use in such applications unless Lumissil Microsystems receives written assurance to its satisfaction, that:

- a.) the risk of injury or damage has been minimized;
- b.) the user assumes all such risks; and
- c.) potential liability of Lumissil Microsystems is adequately protected under the circumstances.

26. Errata

27. Revisions

Revision	Detailed Information	Date
A	First Formal Release	2021.02.01
B	<ol style="list-style-type: none"> 1. Update CS8975 single supply voltage from 2.35V to 5.5V instead of “2.5V to 5.5V” support 2. Add AEC-Q100 qualification 3. Update block diagram for SOSC32/128 KHz and add Buzzer/Melody 4. Revise one system clock from 128KHz SOSC to SOSC32KHz 5. Revise contents for Section 11 IOSC and SOSC 6. When Analog Comparators (ACMP) is enabled, each comparator consumes about 40uA (instead of early claimed 250uA). Individual comparator when enabled consumes about 40uA/each (instead of 80uA/each), and the unity gain buffer consumes about 60uA/80uA (instead of 400uA/800uA) under 3V/5V supply conditions. The above two descriptions are for Section 13 Analog Comparators (ACMP) and 8-bit DAC 7. Add red color indication for three available writer mode commands (ERASEMM, ERASEMMIFB and READVERIFYMM) in locked state. The above description is for Section 17 Writer mode 8. Revise “Supply Voltage for IO and 1.5V regulator” within 19.2 Recommended Operating Condition” from 2.5~5.5 to 2.35~5.5 The above description is for 19.2, 19.3 & 19.4 of Section 19 Electrical Specifications 9. Add information for “Maximum sleep mode IDD at 85°C” & revise “Maximum sleep mode IDD at 125°C” from 30uA to 40uA. The above description is for Section 19.3 DC Electrical Characteristics 10. Add RSTN RESET input High and Low voltage and Hysteresis Specification. The above description is for Section 19.3 DC Electrical Characteristics 11. Add more detailed information about “GPIO DC Characteristics” and update “ADC11 Characteristics”. The above description is for Section 19.3 DC Electrical Characteristics 12. Add Flash Memory Timing The above description is for Section 19.4 AC Electrical Characteristics 13. Add Specification for “Temperature and VDD variation 125°C”. The above description is for Section 19.4 AC Electrical Characteristics 14. Reword content for clear explanation 	2022.03.17
C	<ol style="list-style-type: none"> 1. Add WQFN-16 package support and also land pattern and POD information. 2. Add IS32CS8975 ordering number for WQFN-16 package. 3. Revise Pin 1 name of SOP-8 and TSSOP-16 from VCC to VDDH 4. Add WQFN-16 PINOUT 5. Remove “Stop WDT3 increment in STOP/SLEEP mode” function for SLEEPDIS[2-0] of WDT3CF Watchdog Timer 3 register. The above description is from Section 1.8 Watchdog Timer. 	2022.05.03

Revision	Detailed Information	Date
D	<ol style="list-style-type: none"> 1. Support passive proximity sensing. 2. Update “Features” for interrupt support as “All GPIO pins can be assigned to two external interrupts” 3. Delete 256B IRAM and 1792B XRAM in product “Features” 4. Add “Halogen-Free compliant” claim in product “Features” 5. Add Pin P00 as a multiple function key for CREF/DAC in “PIN Description and Multifunction Table” 6. Update XRAM up to 0x03FFH in “MEMORY MAP” 7. WTST wait state cycle modification. For example, default WTST=0x07 and wait state cycle=8. Update WTST description as “WTST holds the information about Program Memory access time” and modify “Wait State Cycle” as “Access Time (SYSCLK)” in the WTST setting table. The above description is from 1.2 Addressing Timing and Memory Modes 8. Add description for MCON “MCON is not meaningful in this chip because it only contains on-chip XRAM and MCON should not be modified from 0x00.” in Section 1.2 Addressing Timing and Memory Modes. 9. TA/TB Protect support modification: <ul style="list-style-type: none"> * Remove TA Protect support for register WTST * Only support bit 0 WDT1CLR of WDCON register for TA Protect * Remove TB Protect support for registers FLSHDATL, FLSHDATH, FLSHADL and FLSHADH * Modification TB Protect support of Flash Zone protection from FLSHPRT[0] to FLSHPRT[15] * TB Protect support for register LVDCFG except bit 0 LVTIF 10. Revise TCON register description for PINT1F and PINT0F. The above description applies to TCON descriptions in Section 1.5 Interrupt System and Section 1.9 System Timers – T0 and T1 11. Description modifications for bits T1CKDCTL and T0CKDCTL of register CKCON (0x8E). Please refer to Section 1.8 Watchdog Timer 12. Modify SYSCLK as SYSCLK cycle for “SYSCLK cycle*(HOLDT[3:0]+3) ≥ 300nsec hold time” equation for I2CSST2 register. Please refer to Section 3. I²C Slave Controller 2 13. Update 11.2 SOSC description and “Slow oscillator function block”. Rename as 11.2 SOSC 128KHz 14. Remove Section 11.3 Clock output 15. Modify IFB table in Section 16. Information Block IFB as below Update address 27, 28, 29, and 2A to “Reserved” Update address 31 from “SOSC 256kHz Trim” to “Reserved” Update address “44-FF” to “44-1FF” 16. Revise VDDH to VDD to synchronize VDD power name in Section 19. Electrical Specification 17. Add AEC-Q100 qualification for product “Features” 18. Update the operation descriptions for CRCMODE[2-0] of CCCFG register in Section 1.15 Checksum/CRC Accelerator 19. Update power saving mode support for idle, stop, and sleep in “Features” section. 20. Add IFB addresses 34 & 35 Timer 0 TRIM function and update IFB address 41–43 as reserved. Please refer to Section 16 Information Block IFB 21. Add “TSCA compliance” support 	2023.08.04